

# CLARKE®



WARNING: Do not use the machine without reading this manual

## PETROL DRIVEN POWER WASHER

MODEL NO: TIGER 1800

PART NO: 7320200

### OPERATION & MAINTENANCE INSTRUCTIONS



LS0315

---

## **INTRODUCTION**

---

Thank you for purchasing this CLARKE petrol driven power washer.

Before attempting to use this product, please read this manual thoroughly and follow the instructions carefully. In doing so you will ensure the safety of yourself and that of others around you, and you can look forward to your purchase giving you long and satisfactory service.

---

## **GUARANTEE**

---

This product is guaranteed against faulty manufacture for a period of 12 months from the date of purchase. Please keep your receipt which will be required as proof of purchase.

This guarantee is invalid if the product is found to have been abused or tampered with in any way, or not used for the purpose for which it was intended.

Faulty goods should be returned to their place of purchase, no product can be returned to us without prior permission. This guarantee does not effect your statutory rights.

---

## **ENVIRONMENTAL RECYCLING POLICY**

---

Through purchase of this product, the customer is taking on the obligation to deal with the WEEE in accordance with the WEEE regulations in relation to the treatment, recycling & recovery and environmentally sound disposal of the WEEE.

In effect, this means that this product must not be disposed of with general household waste. It must be disposed of according to the laws governing Waste Electrical and Electronic Equipment (WEEE) at a recognised disposal facility

---

# GENERAL SAFETY RULES

---



**WARNING: WATER AT HIGH PRESSURE CAN BE DANGEROUS AND CAN CAUSE DAMAGE IF THE OPERATOR IS CARELESS. DO NOT LET PERSONNEL OPERATE THIS PRESSURE WASHER UNLESS THEY ARE KNOW THE SAFETY PRECAUTIONS.**

---

1. **DO NOT** point the spray at other people, animals, electrical equipment or the machine itself.
2. **DO NOT** hold your finger over the high pressure nozzle.
3. **DO NOT** let children or untrained personnel use this machine.
4. **DO NOT** operate the machine with any of the covers removed.
5. **DO NOT** try to repair this machine. Always refer to your Clarke service department for all repairs.
6. **DO NOT** supply any liquid other than water to the water inlet.
7. **DO NOT** use the detergent pickup facility to introduce flammable liquids/solvents, e.g. paint thinners, petrol, oil as there is a risk of explosion.
8. **ALWAYS** release the remaining pressure in the system; turn off the water supply and operate the trigger before you remove hoses or accessories.
9. **ALWAYS** keep the machine dry and away from the water spray.
10. **ALWAYS** use protective clothing and safety glasses. Loose particles and other items can be propelled at high speed by the water spray.
11. **ALWAYS** hold the gun securely and expect it to 'kick' when you pull the trigger.
12. **ALWAYS** respect the requirements of the local water company. Pressure washers may only be connected to the mains water supply if a system separator (also known as a backflow preventer) is installed in the supply hose.
13. **ALWAYS** disconnect from the water supply, and make sure that you drain the system when not in use. Keep in a cool dry location.
14. **ONLY** use detergents that are suitable for pressure washers, we recommend that you use CLARKE Traffic Film Remover or CLARKE Wash and WAX (available from your dealer).
15. **WARNING** High pressure water jets can be dangerous, the jet must not be directed at a person or anything that they are wearing.
16. **WARNING** High pressure hoses, fittings and couplings are important for the safety of the machine. Use only hoses, fittings and couplings recommended by the manufacturer.
17. **WARNING** Water that passes through a system separator (also known as a backflow preventer) is not safe to drink.
18. **DO NOT** use the pressure washer if there is damage to the inlet/outlet hose or the machine.

# SAFETY SYMBOLS

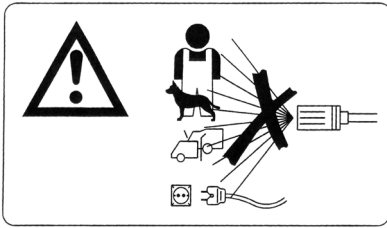

**WARNING:** Do not direct discharge stream at persons or animals. Keep clear of nozzle.

**WARNING:** Never direct spray toward any electrical device or electrical outlet.



**General Warning, indicates that failing to follow these instruction could result in injury or damage to the machine.**



To reduce the risk of injury, read the manual before use.



**ALWAYS** wear safety glasses when using this machine.



**DANGER:** Risk of fire or explosion. Shut off engine before adding fuel. Keep work area free of combustible materials. Do not spray flammable liquids.



**DANGER:** Risk to breathing. Engine exhaust fumes can kill. For outdoor use only. Work in a well ventilated area.



**WARNING:** Risk of injection or severe injury. Do not direct discharge stream at persons or animals. Keep clear of nozzle. This machine is to be used only by qualified operators.



**WARNING:** Risk of spray injury. Spray can propel objects. Always wear ANSI approved Z87.1 Safety Glasses.



**WARNING:** Risk of chemical burn. Never spray acids, corrosive or toxic chemicals. Use only cleaners formulated for pressure washers.



**WARNING:** Risk of electrocution. Never direct spray toward any electrical device or electrical outlet.



**WARNING:** Risk of unsafe operation. Keep children away from this equipment. Gun kicks back. Hold with both hands.



**WARNING:** Risk of hot surfaces. Avoid contact with hot engine exhaust components. Don't allow hoses to contact the engine muffler during or after use.

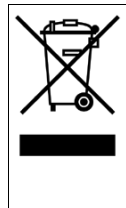

Recycle unwanted materials instead of disposing of them as waste. All tools, accessories and packaging should be sorted, taken to a recycling centre and disposed of in a manner which is compatible with the environment.

# OVERVIEW

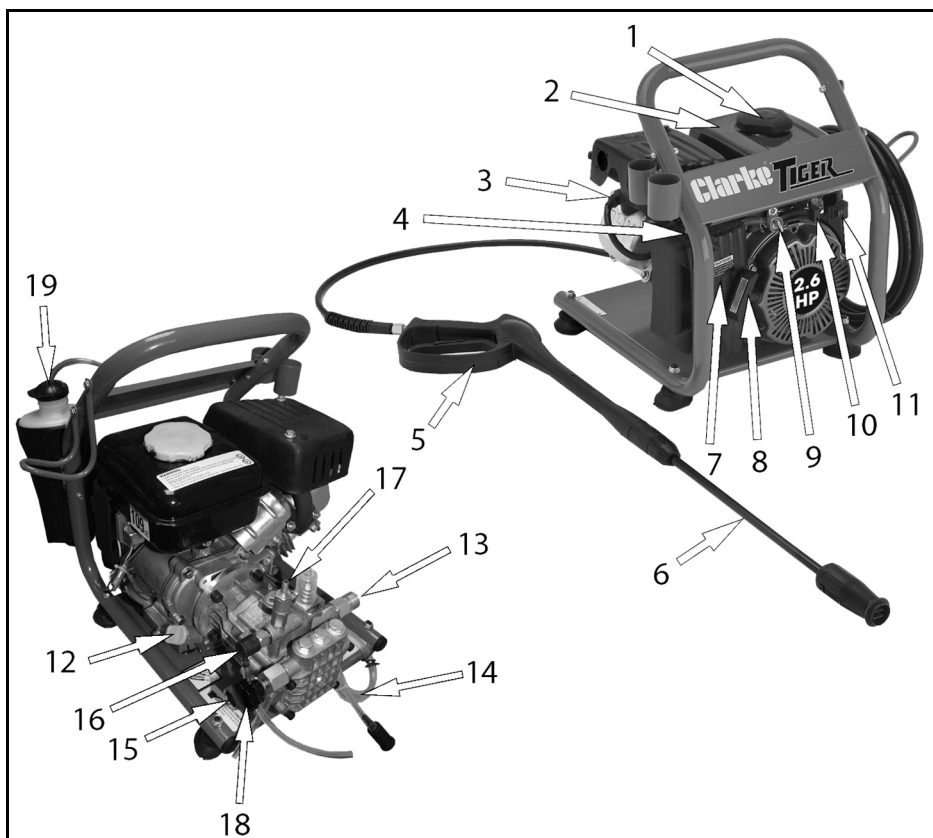

NO	DESCRIPTION	NO	DESCRIPTION
1	Fuel Tank Cap	11	Engine On/Off Switch
2	Fuel Tank	12	Oil Filler Cap
3	Spark Plug	13	Water Outlet
4	Choke	14	Detergent Hose
5	Gun Assembly	15	Water Inlet
6	Lance	16	Bypass Drain Hose
7	Air Filter Cover	17	Self-suction Valve
8	Recoil Starting Handle	18	Exhaust Valve
9	Fuel Valve	19	Water Bottle
10	Throttle		

---

## UNPACKING AND ASSEMBLY

---

Unpack your pressure washer and make sure that the following items are present.

Contact your Clarke dealer immediately if any parts are missing or damaged.

- 1 x Petrol Power Washer
- 1 X Hose Bracket
- 1 X Gun / Lance Bracket
- 1 X Tap Adaptor (Fitted To Unit)
- 1 X Output Hose For Gun
- 1 x Gun Assembly
- 1 x Lance Assembly
- 1 X Suction Hose
- 1 X Filter For Suction Hose
- 1 X Water Bottle
- 1 X Bottle Bracket

### FITTING THE HOSE STORAGE BRACKET

1. Fit the hose storage bracket into the position shown and secure using the bolts, washers and nuts supplied.



### FITTING THE LANCE STORAGE BRACKET

1. Fit the lance storage bracket into the position shown and secure using the bolts, washers and nuts supplied.



## FITTING THE WATER BOTTLE

1. Fit the bracket to the frame as shown using the bolts, nuts and washers supplied.
2. Slide the bottle holder over the bracket and place the bottle in the holder.

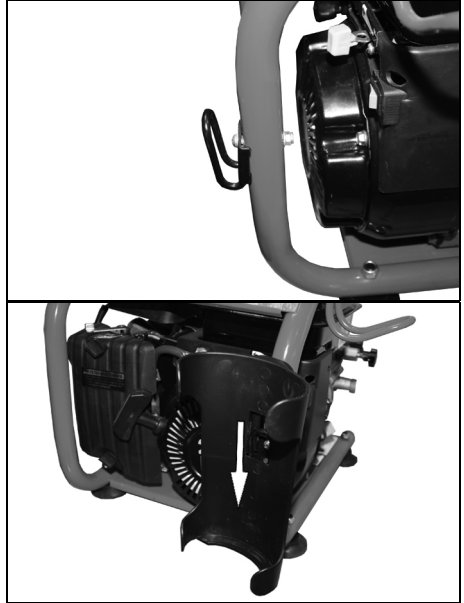

## CONNECT THE WATER SUPPLY

Always follow the regulations of your local water supplier. The pressure washer must never be connected to the drinking water supply without using a system separator (also known as a backflow preventer) available from most hardware stores.

**NOTE:** Water that has flowed through a system separator is considered non-drinkable.

1. Connect a water supply hose (not supplied) to the water inlet.

**NOTE:** Use a good quality water hose with a standard quick fit coupling.

**NOTE:** This machine has the ability to draw its own water, meaning you can use water not under pressure such as rainwater collected in a water butt. See page 16.

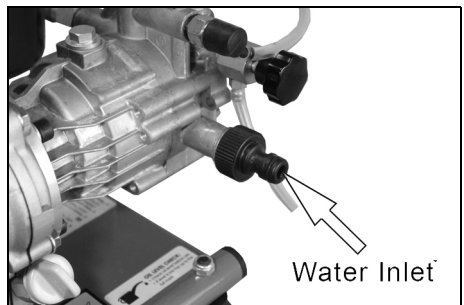

## CONNECT THE HIGH PRESSURE HOSE TO THE GUN

1. Screw the high pressure hose onto the gun assembly.
2. Use a spanner to tighten the connector.

**NOTE:** Make sure the connection is secure.

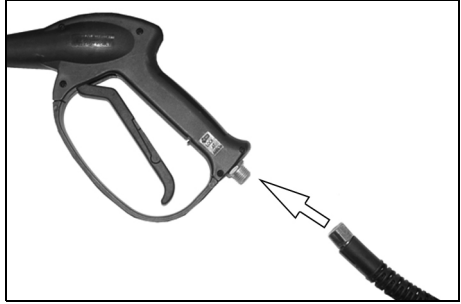

## CONNECT THE HOSE TO THE PRESSURE WASHER

1. Screw the hose to the pressure washer.
  - Tighten the connector, hand tight only. Do not use a spanner.

**NOTE:** Make sure the connection is secure.

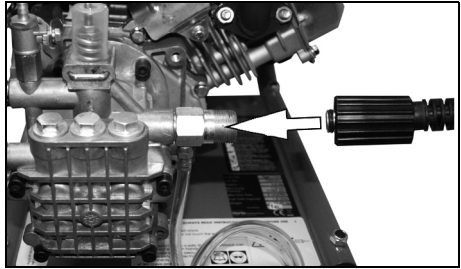

## ATTACH THE LANCE

1. Screw the lance on to the end of the gun assembly.

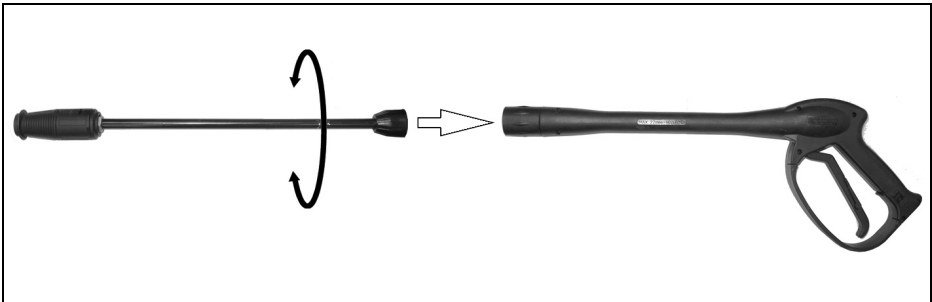



## BEFORE USE



**WARNING: PLACE THE PRESSURE WASHER ON LEVEL GROUND WITH THE ENGINE SWITCHED OFF.**

**WARNING: TAKE CARE NOT TO TOUCH ANY HOT PARTS OF THE PRESSURE WASHER WHEN CHECKING THE OIL LEVEL.**

**IMPORTANT:** *The engine is supplied without any oil in it and must be filled to the correct level before use, see below.*

### ADDING ENGINE OIL

1. Turn the oil filler cap anticlockwise and remove it from the engine, wipe the integral dipstick with a clean cloth.
2. Insert the oil filler cap back into place and then remove it again.
  - Do not screw it in when doing this.
3. If the oil reads low on the dipstick, add oil to the oil reservoir (Max 0.6L).
  - We recommend the use of SAE10W-30 oil.
  - Do not overfill the oil reservoir.
4. Replace the oil filler cap.

**NOTE:** Running the engine with insufficient oil will cause engine damage.

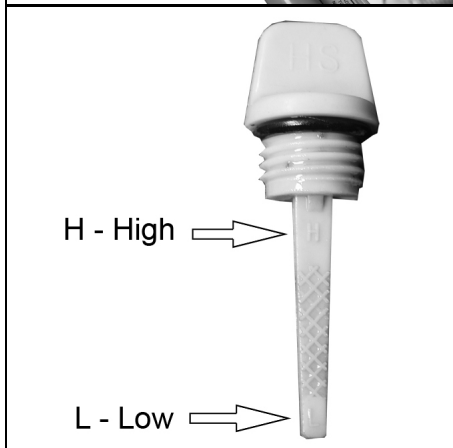
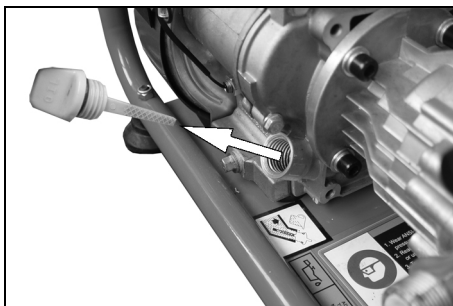

## ADDING FUEL

- Refuel in a well-ventilated area, away from any sources of ignition.
- If the engine has been running, allow it to cool before refueling.
- Do not leave fuel within the reach of children.
- Refuel carefully to avoid spilling fuel.

### 1. Remove the fuel tank cap.

- Just inside the fuel tank is a fuel strainer, which should be checked periodically and any contaminants which have accumulated must be removed.



### 2. Pour unleaded petrol through the fuel strainer and into the fuel tank.

- Do not fill above the fuel strainer shoulder.
- Use unleaded petrol with a pump octane rating of 86 or higher.

### MAXIMUM FUEL LEVEL

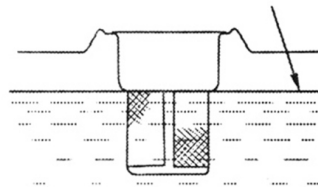

### 3. After refueling, tighten the fuel tank cap securely.

---

# STARTING YOUR PRESSURE WASHER

---

1. Turn the water supply on, make sure that the tap is fully open.



**WARNING: FAILURE TO TURN ON THE WATER COULD CAUSE DAMAGE TO THE PRESSURE WASHER.**

2. Set the choke lever to the START position.

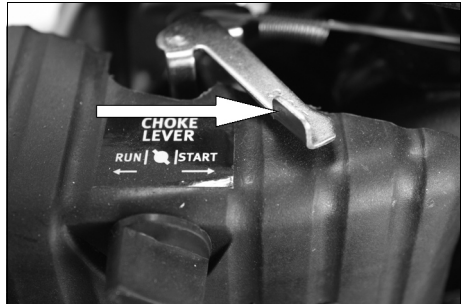

3. Set the fuel supply valve to the ON position.

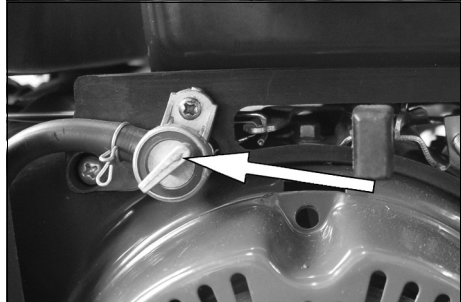

4. Slide the throttle 3/4 of the way to the left.

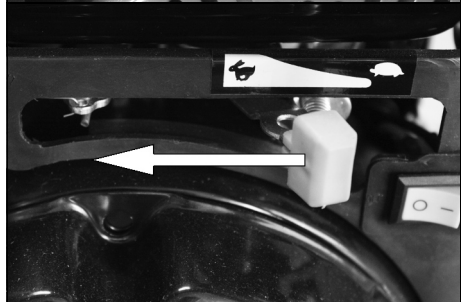

5. Set the engine switch to the on (I) position.

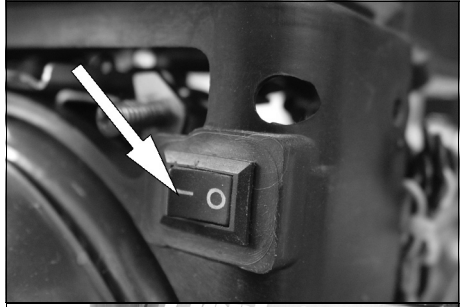

6. Pull the recoil starting handle lightly until you start to feel resistance and then pull up sharply to start the engine.

- You may have to do this more than once.

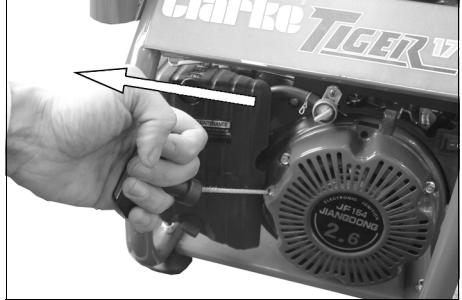

**WARNING: ONCE THE PRESSURE WASHER ENGINE HAS STARTED, RELEASE THE STARTING HANDLE SLOWLY TO AVOID INJURY/DAMAGE AS IT RECOILS.**

7. Slide the choke lever to the RUN position.

- The pressure washer is now ready for use.

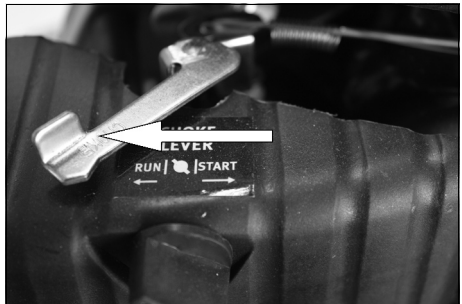

8. Release the trigger lock.

9. Ensuring that you have a firm footing and that you are also holding the gun assembly and spray lance firmly, pull the trigger on the gun to start water flow.

- The lance and gun will kick back when the trigger is first pulled.

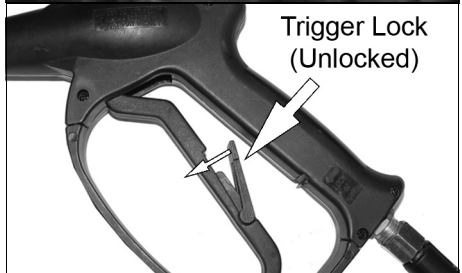

## INTERRUPTING OPERATION

1. Release the trigger.

**NOTE:** The pressure washer will automatically go into bypass mode.



**WARNING: DO NOT ALLOW THE UNIT TO OPERATE IN BYPASS MODE FOR MORE THEN TWO MINUTES AT ANY TIME. TURN THE UNIT OFF IF IT IS NOT GOING TO BE USED FOR A PERIOD LONGER THAN THIS. SEE PAGE 14.**

**NOTE:** If you notice water coming from the drain tube attached to the pump, please note that this is a safety feature and should be expected, it cools the pump by releasing some of the hot water within the pump and replacing it with fresh 'cool' water.

2. Rotate the trigger lock to the locked position.

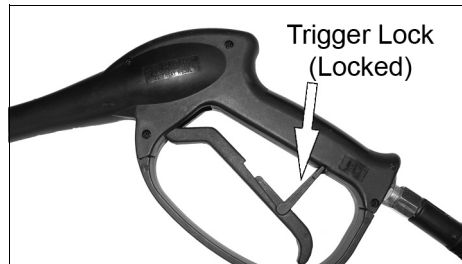

## ADJUSTING THE SPRAY NOZZLE

The nozzle is adjustable to allow you to adjust the water delivery from a narrow jet of water to a wide spray. To adjust the nozzle, proceed as follows:

1. Hold the shaft of the lance in one hand.
2. Twist the nozzle with the other hand.
3. The spray varies between narrow and wide as you turn the nozzle.



- The narrow jet should be used to clean small areas where a small spray is required.
- The wide spray should be used for cleaning large areas.

## ADJUSTING THE PRESSURE

Hold the rear of the nozzle and slide the front of the nozzle forwards to low pressure and backwards for high pressure.

Other ways to adjust the pressure include. Changing the distance you are from the surface being cleaned and adjusting the spray to a wider angle (lowers the pressure).

## APPLYING CHEMICALS AND CLEANING AGENTS

To improve the cleaning performance, You can introduce chemical cleaning agents (detergents) to the water jet using the detergent pickup hose.

1. Place the detergent pickup hose into a container holding the chemical/cleaning solution.
  - Only use detergents recommended for use with pressure washers, such as CLARKE Traffic Film Remover which is a powerful low foaming agent for car cleaning, patio cleaning etc., or CLARKE Wash & Wax, both available from your CLARKE dealer.
2. Hold the rear of the nozzle and slide the front of the nozzle forwards to low pressure.
3. Spray the detergent onto the vehicle, patio etc.
  - Allow the detergent a little time to work itself into the grime.



CAUTION: IF YOUR EYES COME INTO CONTACT WITH ANY CLEANING FLUIDS, RINSE THEM IMMEDIATELY WITH PLENTY OF FRESH CLEAN WATER, AND SEEK MEDICAL ADVICE IF REQUIRED.

4. To rinse, remove the detergent pickup hose from the container holding chemical/cleaning solution and use the pressure washer as normal.

## SHUTTING DOWN

1. After each use, if you have applied chemicals, place the detergent pickup hose into a container of clean water and run clean water through the detergent pickup hose to flush the system thoroughly.

**NOTE:** Failure to do so could cause damage to the pump.

2. Move the throttle control lever to the right.
3. Turn off the engine switch.

**NOTE:** NEVER turn the water off with the engine running.

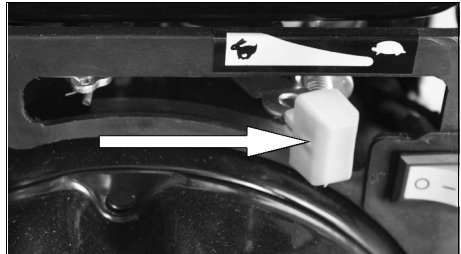

4. Turn the water supply off at the tap.
5. Release the pressure in the pump and hose by squeezing the trigger for a few seconds until no more water comes out of the nozzle.

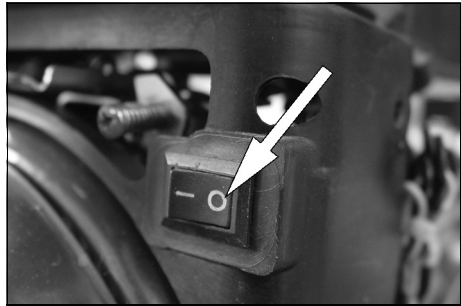

6. Turn off the fuel supply valve.

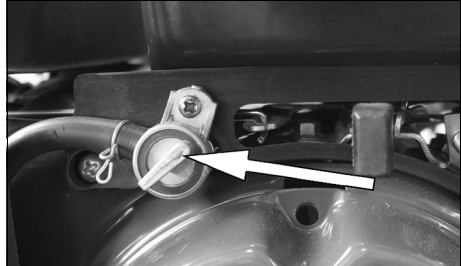

7. Rotate the trigger lock to the locked position.

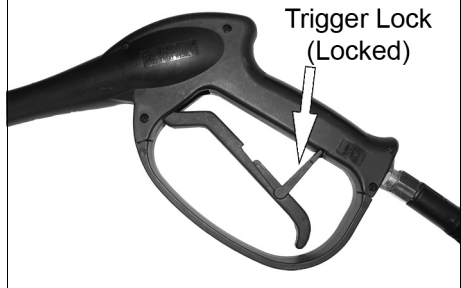

## WATER BUTT CONNECTION

This machine has the ability to draw its own water, meaning you can use water not under pressure such as rainwater collected in a water butt.

To do this you must carry out the following procedure.

1. Remove the quick connector from the water inlet.
2. Attach the filter to the end of the suction pipe supplied.
3. Connect other end of the suction pipe to the pressure washer.
4. Fill the supplied bottle with water.
5. Connect the hose from the bottle to the self-suction valve shown.
6. Start the pressure washer See "Starting your Pressure Washer" on page 11.

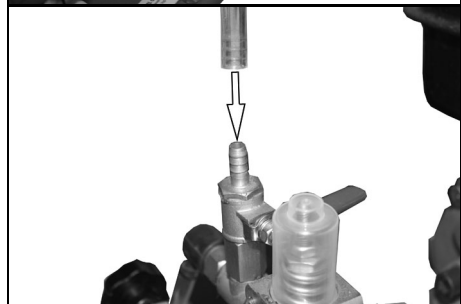
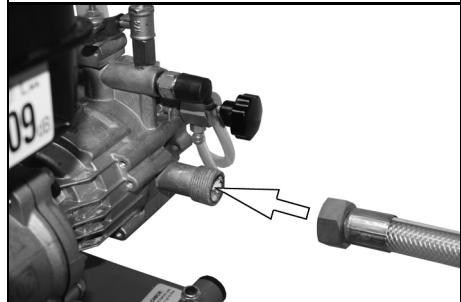
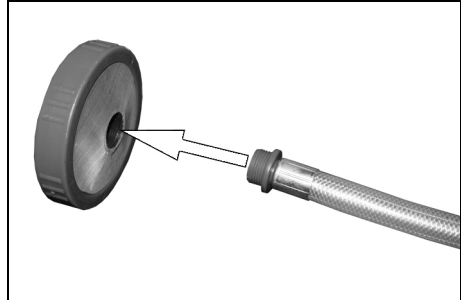
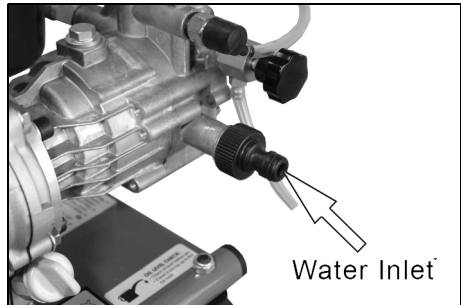



7. Release the exhaust valve.

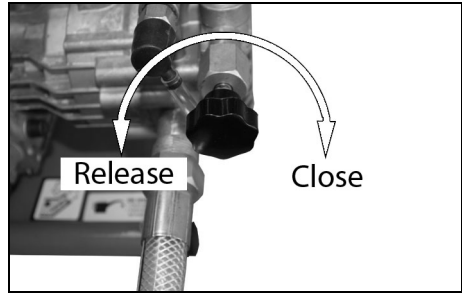

8. Turn the self-suction valve to the on position.

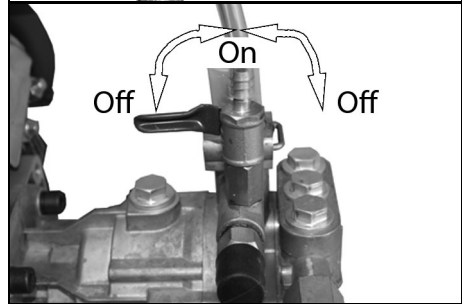

9. Release the trigger lock and pull the trigger.

10. When the water spray is at high pressure, close the exhaust valve and set the suction valve to the OFF position.

**NOTE:** If the water butt runs out of water, the pressure washer will need to be primed before use by repeating steps 4-10.

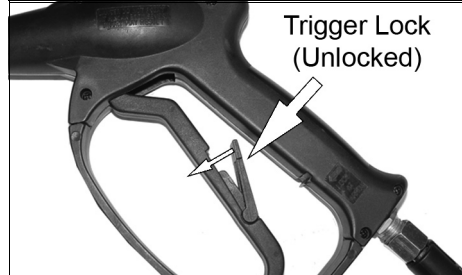

---

## STORAGE

---

1. Follow the Shutting down procedure on page 14.
2. Disconnect the high pressure hose and drain all water from the hose.
3. Coil the hose and store the gun/lance in the holders located on the side frame of the pressure washer.

### STORAGE PROCEDURE

Make sure that the pressure washer has been thoroughly cleaned before storing it in a clean dry place.

For long term storage See page 20.

---

# MAINTENANCE

---

## CLEANING THE NOZZLE

1. Shut off the pressure washer and turn off the water supply.
2. Pull trigger on the gun handle to relieve any water pressure.
3. Disconnect the lance from the gun assembly.
4. Remove any obstructions with the nozzle cleaning tool provided and back flush with clean water.
5. Direct the water supply into the end of the lance for 30 seconds to back flush loose particles.
6. Reconnect the lance to the gun assembly and turn on the water supply.

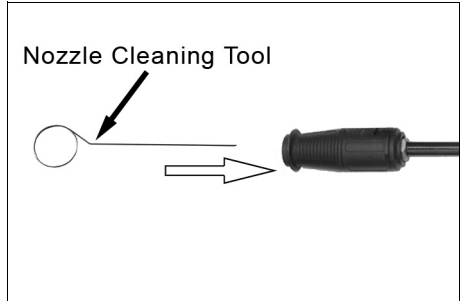

## CLEANING THE WATER INLET FILTER

The screen filter should be checked periodically and cleaned if necessary.

1. Remove the filter from the water inlet of the pump as shown.
2. Clean the filter by flushing both sides with water.
3. Replace the filter into the water inlet.
  - Do not operate the pressure washer without the filter properly installed.

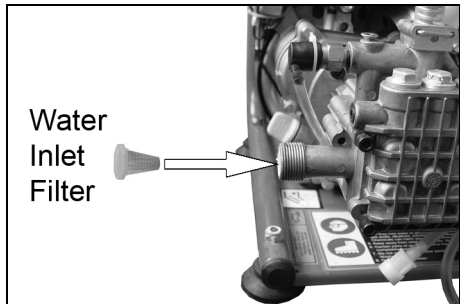

## CLEANING THE FUEL STRAINER

Just inside the fuel tank is a fuel strainer, check this periodically and remove any contaminants which may have accumulated.

1. Open the fuel tank cap.
2. Remove the fuel strainer.
3. Flush away any contaminants.
4. Replace the fuel strainer.
  - Do not operate the pressure washer without the fuel strainer properly installed.



## CLEANING THE AIR FILTER

1. Remove the two screws on the air filter cover.
2. Remove the air filter cover
3. Remove the air filter element.
4. Wash it in a solution of warm water and mild detergent.



**WARNING: DO NOT USE FLAMMABLE SOLVENTS OR PETROL TO CLEAN THE AIR FILTER**

5. Rinse thoroughly and leave it to dry. Once it is completely dry, immerse the filter in clean engine oil and squeeze the filter to remove excess oil.
  - If the air filter is damaged contact Clarke spare parts department for a replacement.
6. Replace the filter into its original position and refix the air filter cover.

## CHANGING THE SPARK PLUGS



CAUTION: ALLOW THE ENGINE TO COOL BEFORE REMOVING THE SPARK PLUG.

1. Remove the spark plug cap from the spark plug.
2. Use the supplied spark plug spanner to remove the spark plug.
3. Remove any carbon that has accumulated around the sparkplug.
4. Check the overall condition of the spark plug and replace if necessary.
5. Check the spark plug gap (a), it should be between 0.7 and 0.8 mm, adjust if necessary.
6. Reinstall the spark plug and refit the spark plug cap.

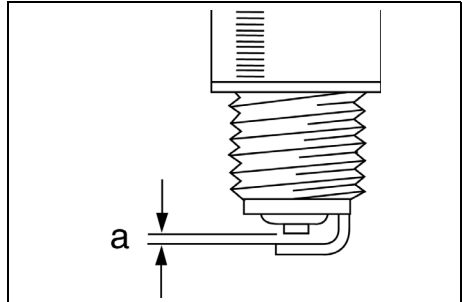

## LONG TERM STORAGE

For long term storage,

1. The petrol tank should be drained.
  - Ensure that the engine is cold before draining the tank.
2. Remove the fuel tank cap and use a pump type syphon to drain the petrol into an appropriate, clean container.
  - Do not store petrol for long periods of time.
  - Dispose of excess petrol in an environmentally safe way. Your local recycling centre can advise you on the best method of disposal.
3. After the petrol tank has been drained, start the engine and allow it to use any petrol that may remain in the engine, or fuel pipe.
4. Make sure that the power washer has been thoroughly cleaned before storing it in a clean dry place.

## TROUBLESHOOTING

If the following does not solve your problem, please contact the CLARKE service department.

<b>PROBLEM</b>	<b>CAUSE</b>	<b>SOLUTION</b>
Engine will not start (see engine manual for further engine troubleshooting)	No fuel.	Add fuel.
	Low oil.	Add oil.
	Pressure builds up after two pulls on the recoil starter or after initial use.	Squeeze the gun trigger to relieve the pressure.
	Spark plug lead not attached.	Attach the spark plug lead.
	Engine switch is in the OFF position.	Set the engine switch to the ON position.
	Choke lever is set to the on position when the engine is already warm.	Set the choke lever to the OFF (right) position.
	Fuel valve closed.	Open the fuel valve.
Lack of pressure (initial use)	Leak in the high pressure hose fitting.	Tighten the fitting, use sealant tape if required.
	Nozzle is obstructed.	Clear the nozzle.
	Water filter screen is clogged.	Remove and clean the filter.
	Air in the hose.	Turn off the engine. Turn off the water supply. Disconnect the water source from the pump inlet and turn on the water source to expel the air from the hose. When all the air has been removed, turn off the water supply and reconnect the hose. Turn on the water supply and pull the trigger to expel any air in the gun/lance.

<b>PROBLEM</b>	<b>CAUSE</b>	<b>SOLUTION</b>
Lack of pressure (initial use) continued	Choke lever is in the ON position.	Set the choke lever to the OFF position.
	Throttle control lever is not set high enough.	Move the throttle control lever to left.
	High pressure hose is too long.	Make sure the high pressure hose is under 100 feet.
Will not draw chemicals	Chemical filter is blocked.	Clean the filter.
	Chemicals being used are too thick.	Dilute the chemicals. The chemicals should have the consistency of water.
	High pressure hose is too long.	Use a longer supply hose instead of a longer high pressure hose.
	Chemical build up inside the chemical injector.	Have the parts cleaned or replaced by your dealer.
Lack of pressure (after a period of normal use)	Worn seal or packing.	Have them replaced by your dealer.
	Worn or obstructed valves.	Have them replaced by your dealer.
Water leaking at the pump	Loose connections.	Tighten.
	Piston packings worn.	Have it replaced by your dealer.
	Worn or broken O-rings.	Have it replaced by your dealer.
	Pump head or tubes damaged from freezing.	Have it replaced by your dealer. See "Storage" on page 17.
Water leaking from the drain hose	Pump is overheating	This is a safety feature and should be expected, it cools the pump by releasing some of the hot water within the pump and replacing it with fresh 'cool' water.
Oil leaking at the pump	Oil seals worn.	Have them replaced by your dealer.
	Worn O-rings.	Check and replace.
Pump pulsates	Nozzle obstructed.	Clear the nozzle.

# SPECIFICATIONS

<b>ENGINE</b>	
Engine type	Petrol (unleaded). OHV Single Cylinder 4 stroke forced air cooling
Capacity/displacement:	87 cc
Oil Capacity	0.6 L
Lubrication Grade	SAE10W-30
Fuel Tank Capacity:(Litres)	1.6L
<b>WATER CONNECTION</b>	
Max. Feed Temperature	50 °C
Max. Feed Pressure	3-6 Bar
<b>PERFORMANCE DATA</b>	
Maximum Pump Pressure	110 Bar
MAximum Suction Height	1.5 m
Working Pressure	70 Bar
Maximum Water Flow	6 l/min
<b>NOISE &amp; VIBRATION</b>	
Sound Pressure Level LpA	87 dB(A)
Sound Power Level LWA	100 dB(A)
Guaranteed Sound Power Level LWA	102 dB(A)
Uncertainty Factor K	2.28
Vibration	4.494 m/s
Uncertainty Factor K	1.5
<b>DIMENSIONS</b>	
Length	470 mm
Width	340 mm
Height	450 mm
Weight	19.55 kg

# EXPLODED DIAGRAM

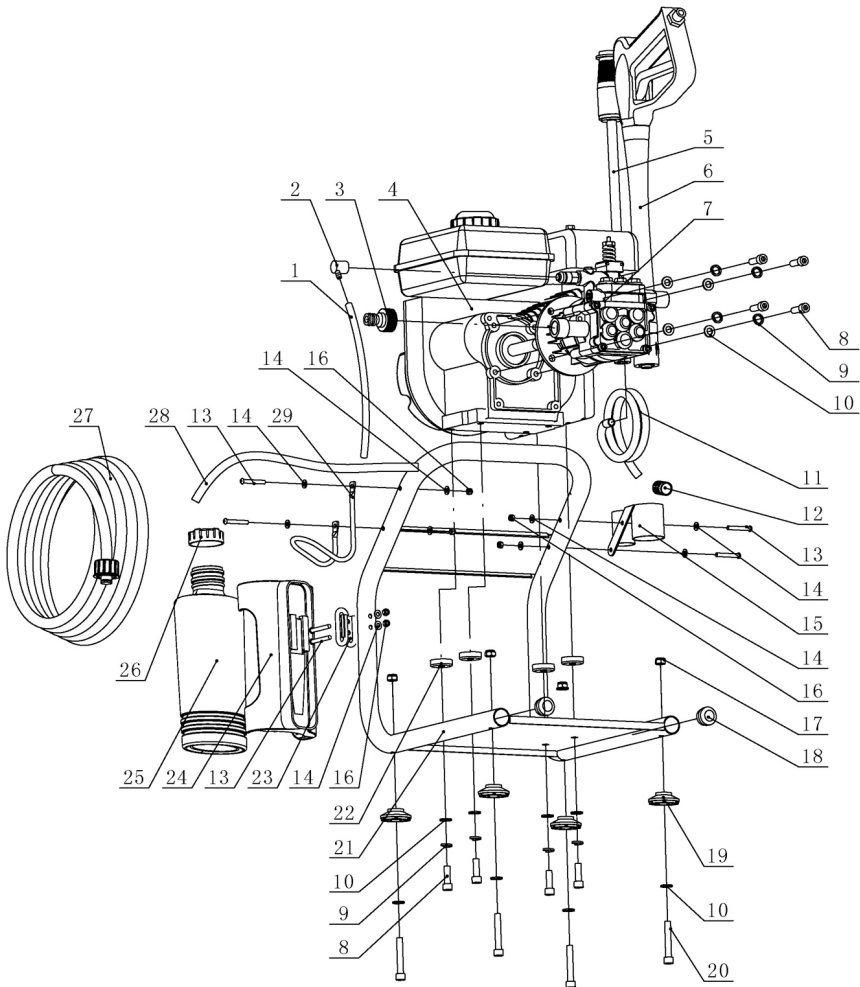

**WARNING: TO ENSURE MACHINE SAFETY, USE ONLY ORIGINAL SPARE PARTS FROM CLARKE INTERNATIONAL.**



## PARTS LIST

NO	DESCRIPTION	PART NO	NO	DESCRIPTION	PART NO
1	Drain Hose	RKTIG180001	16	Locknut M5	RKTIG180016
2	Thermal Relief Cap	RKTIG180002	17	Locknut M8	RKTIG180017
3	Inlet Connector	RKTIG180003	18	Rubber Plug	RKTIG180018
4	Petrol Engine	RKTIG180004	19	Rubber Foot	RKTIG180019
5	Lance	RKTIG180005	20	Innerhex Bolt M8x40	RKTIG180020
6	Gun	RKTIG180006	21	Frame	RKTIG180021
7	High Pressure Pump	RKTIG180007	22	Engine Isolator	RKTIG180022
8	Innerhex Bolt M8x25	RKTIG180008	23	Water Bottle Hook	RKTIG180023
9	Spring Washer	RKTIG180009	24	Water Bottle Frame	RKTIG180024
10	Washer	RKTIG180010	25	Water Bottle	RKTIG180025
11	Injection Hose	RKTIG180011	26	Water Bottle Cap	RKTIG180026
12	Injection Filter	RKTIG180012	27	High Pressure Hose	RKTIG180027
13	Cross Bolt M5x35	RKTIG180013	28	Water Pipe	RKTIG180028
14	Washer	RKTIG180014	29	Hose Hook	RKTIG180029
15	Gun Holder	RKTIG180015			

## ACCESSORIES

The range of accessories listed below may be purchased from your CLARKE dealer.

ITEM	PART NUMBER
5 Litres Detergent (Traffic Film Remover)	3050821
25 Litres Detergent (Traffic Film Remover)	3050820
5 Litres Wash 'n' Wax	3050815

# DECLARATION OF CONFORMITY



**Clarke**<sup>®</sup>  
**INTERNATIONAL**

Hemnal Street, Epping, Essex CM16 4LG

## DECLARATION OF CONFORMITY

This is an important document and should be retained.

**Product Description:** Petrol Power Washer  
**Model number(s):** Tiger 1800  
**Serial / batch Number:** N/A  
**Date of Issue:** 11/03/2015  
*(Noise Conformity)*  
**Notified Body:** N/A

**Technical Documentation Holder:** A.R. Pond  
Clarke International  
2a Shrubland Road  
London E10 7RB  
UK

**Conformity Assessment Procedure:** to 2000/14/EC Annex V  
**Manufacturer:** Clarke International  
**Noise Related Value:** 360 l/h  
**Measured Sound Power Level:** 100 dB  
**Guaranteed Sound Power Level:** 102 dB



**Clarke**<sup>®</sup>  
**INTERNATIONAL**

Hemnal Street, Epping, Essex CM16 4LG

## DECLARATION OF CONFORMITY

This is an important document and should be retained.

**We hereby declare that this product(s) complies with the following directive(s):**

- 2004/108/EC *Electromagnetic Compatibility Directive.*
- 2006/42/EC *Machinery Directive.*
- 2000/14/EC *Noise Emissions Directive, (amended by 2005/88/EC).*
- 97/68/EC *Emission of Gaseous and Particulate Pollutants for Internal Combustion Engines to be installed in Non-road Mobile Machinery, (amended by 2010/26/EU)*

**The following standards have been applied to the product(s):**

- EN 55012:2007 +A1:2009, EN61000-6-1:2007, EN 60335-1:2012, EN 60335-2-79:2012,*
- EN ISO 12100:2010.*

The technical documentation required to demonstrate that the product(s) meet(s) the requirement(s) of the aforementioned directive(s) has been compiled and is available for inspection by the relevant enforcement authorities.

**The CE mark was first applied in: 2008**

**Signed:**



**J.A. Clarke**  
Director

# A SELECTION FROM THE VAST RANGE OF

# Clarke®

## QUALITY PRODUCTS

### AIR COMPRESSORS

From DIY to industrial, Plus air tools, spray guns and accessories.

### GENERATORS

Prime duty or emergency standby for business, home and leisure.

### POWER WASHERS

Hot and cold, electric and engine driven - we have what you need

### WELDERS

Mig, Arc, Tig and Spot. From DIY to auto/industrial.

### METALWORKING

Drills, grinders and saws for DIY and professional use.

### WOODWORKING

Saws, sanders, lathes, mortisers and dust extraction.

### HYDRAULICS

Cranes, body repair kits, transmission jacks for all types of workshop use.

### WATER PUMPS

Submersible, electric and engine driven for DIY, agriculture and industry.

### POWER TOOLS

Angle grinders, cordless drill sets, saws and sanders.

### STARTERS/CHARGERS

All sizes for car and commercial use.



**PARTS & SERVICE: 0208 988 7400**

**E-mail: [Parts@clarkeinternational.com](mailto:Parts@clarkeinternational.com) or [Service@clarkeinternational.com](mailto:Service@clarkeinternational.com)**

**SALES: UK 01992 565333 or Export 00 44 (0)1992 565335**

**Clarke® INTERNATIONAL** Hemnall Street, Epping, Essex CM16 4LG  
[www.clarkeinternational.com](http://www.clarkeinternational.com)