

Clarifire®



SWING ARM MAGNIFYING LAMP MODEL NO: SAM170

PART NO: 54605338

ASSEMBLY & OPERATING INSTRUCTIONS



ORIGINAL INSTRUCTIONS

GC0217

INTRODUCTION

Thank you for purchasing your CLARKE swing arm magnifying lamp, which is ideal for fine detail assembly and repair work, stamp collectors, model makers, jewellers, etc.



This product is designed for indoor use only.

Before using this product, read this leaflet thoroughly, and follow the instructions carefully. Although the product is robust it should nevertheless be used with care and consideration, you can then look forward to it giving long and reliable service.

GUARANTEE

This product is guaranteed against faulty manufacture for a period of 12 months from the date of purchase. Please keep your receipt which will be required as proof of purchase.

This guarantee is invalid if the product is found to have been abused or tampered with in any way, or not used for the purpose for which it was intended.

Faulty goods should be returned to their place of purchase, no product can be returned to us without prior permission.

This guarantee does not effect your statutory rights.

ENVIRONMENTAL RECYCLING POLICY



Through purchase of this product, the customer is taking on the obligation to deal with the WEEE in accordance with the WEEE regulations in relation to the treatment, recycling & recovery and environmentally sound disposal of the WEEE.

In effect, this means that this product must not be disposed of with general household waste. It must be disposed of according to the laws governing Waste Electrical and Electronic Equipment (WEEE) at a recognised disposal facility.

ELECTRICAL CONNECTIONS



WARNING: READ THESE ELECTRICAL SAFETY INSTRUCTIONS THOROUGHLY BEFORE CONNECTING THE PRODUCT TO THE MAINS SUPPLY.

Before switching the product on, make sure that the voltage of your electricity supply is the same as that indicated on the rating plate. This product is designed to operate on 230VAC 50Hz. Connecting it to any other power source may cause damage.

This product may be fitted with a non-rewireable plug. If it is necessary to change the fuse in the plug, the fuse cover must be refitted. If the fuse cover becomes lost or damaged, the plug must not be used until a suitable replacement is obtained.

If the plug has to be changed because it is not suitable for your socket, or due to damage, it should be cut off and a replacement fitted, following the wiring instructions shown below. The old plug must be disposed of safely, as insertion into a mains socket could cause an electrical hazard.



**WARNING: THE WIRES IN THE POWER CABLE OF THIS PRODUCT ARE COLOURED IN ACCORDANCE WITH THE FOLLOWING CODE:
BLUE = NEUTRAL BROWN = LIVE**

If the colours of the wires in the power cable of this product do not correspond with the markings on the terminals of your plug, proceed as follows.

- The wire which is coloured **Blue** must be connected to the terminal which is marked **N** or coloured **black**.
- The wire which is coloured **Brown** must be connected to the terminal which is marked **L**, or coloured red

Plug must be BS1363/A approved.

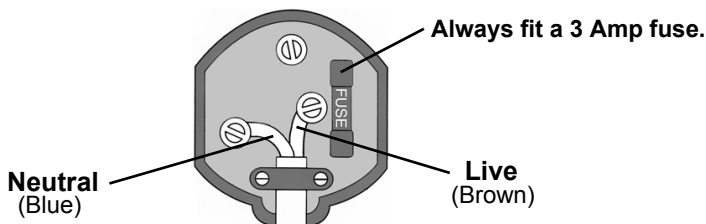

Ensure that the outer sheath of the cable is firmly held by the clamp

We strongly recommend that this machine is connected to the mains supply via a Residual Current Device (RCD)

If in any doubt, consult a qualified electrician. DO NOT attempt any repairs yourself.



This symbol indicates that this is a Class II product, and does not require an earth connection.

ASSEMBLY AND OPERATION

ASSEMBLY

Your lamp is supplied in three parts:-

- The lamp assembly with adjustable arms,
- The G- clamp,
- The holder.

Slide the G-clamp into the slot in the side of the holder, then slide the lamp assembly spigot into the holder.

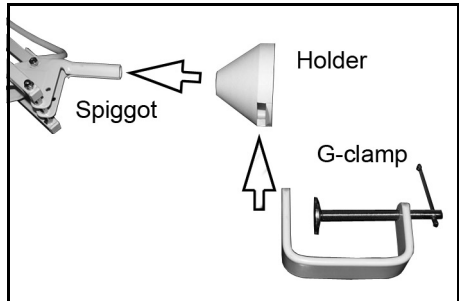

SETTING UP

The G-clamp can be mounted on surfaces with varying angles and such variations can be accommodated by the angulation of the lamp assembly.

The lamp may be rotated freely in the holder by slackening the pinch bolt, adjusting the angle and re-tightening and the arms can be set at any angle.

Do not over tighten the pinch bolt. When it is correctly tightened, the lamp should remain stable in any position.

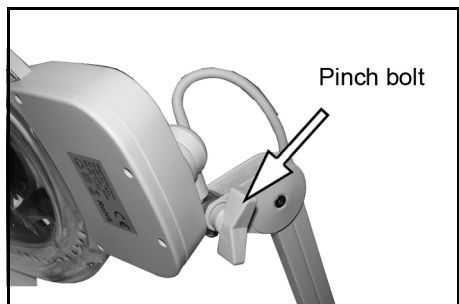

MAINTENANCE

The lamp requires no maintenance other than cleaning the lens. Liquid glass cleaner may be used to clean the lens, used sparingly and with a soft dry cloth. **Do not allow** the LEDs or electrical connections to get wet.

IMPORTANT: Always switch the lamp OFF and unplug from the power supply before cleaning the lens.

1. When not in use, switch off & unplug from the power supply.
2. This product should be stored in a secure, dry place, out of the reach of children. DO NOT leave it exposed to the elements and avoid direct sunlight, direct heat, rain/moisture etc.
3. Keep the external surfaces clean. Avoid impact damage & do not allow this product to come into contact with abrasive or corrosive materials.

4. Do not use solvents, thinners or alcohol for cleaning, as these chemicals will damage the finish. With the lamp unplugged from the power supply, use a dry cloth to wipe over the lamp components.
5. Only use extension leads that are of an appropriate power rating and suitable for the work environment. Inspect the extension lead regularly and replace if damaged.
6. Only use parts and accessories recommended in this manual. Never use unauthorised accessories or attachments which may result in personal injury or damage to the product.

Do not attempt to repair or modify this product or attempt any electrical repair yourself. Consult a qualified electrician or the Clarke Service Department on 020 8988 7400.

SPECIFICATIONS

Model Number	SAM170
Upper/lower arm length	400 mm
Weight	3.3 kg
Operating Temperature	0-55°C
Duty Cycle	S1 (continuous)
Fuse Rating	3A
Power Supply	230V @50Hz
Insulation Class	II
IP Rating	IP20
Efficiency Class	A++,A+,A
Luminance	10600 lux @15 cm
Lumen output	700 @1 m
Colour temperature	6300K
Life expectancy of LED	20,000 hours

COMPONENT PARTS

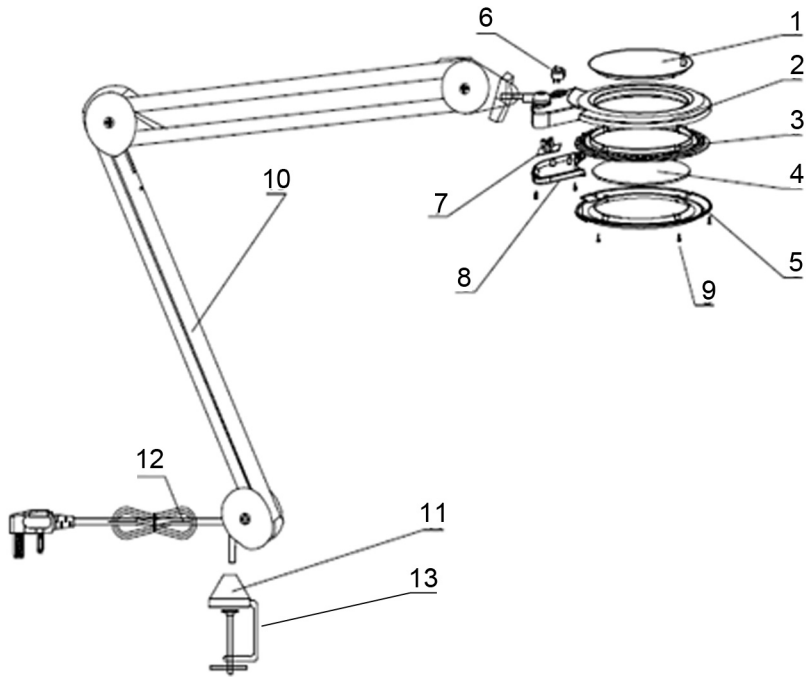

Item No	Description	Qty
1	Lens Cover	1
2	Plastic Head cover	1
3	LED Board	1
4	Lens (3D)	2
5	Diffuser	1
6	On/Off Switch	1
7	LED Driver	1
8	Plastic Back Cover	1
9	Screws	12
10	A3- 4bar Swing Arm Assembly	1
11	C1 Table Holder	1
12	BS Plug & power cable	1
13	G- clamp	1

DECLARATION OF CONFORMITY



Clarke[®]
INTERNATIONAL

Hemnall Street, Epping, Essex CM16 4LG

DECLARATION OF CONFORMITY

This is an important document and should be retained.

We hereby declare that this product(s) complies with the following directive(s):

2014/30/EU *Electromagnetic Compatibility Directive.*

2014/35/EU *Low Voltage Equipment Directive.*

2011/65/EU *Restriction of Hazardous substances.*

The following standards have been applied to the product(s):

EN 60598-2-4:1997, EN 60598-1:2015+AC: 2016, EN, 55015:2015, EN 61547:2010,

EN 61000-3-2:2014, EN 61000-3-2:2013.

The technical documentation required to demonstrate that the product(s) meet(s) the requirement(s) of the aforementioned directive(s) has been compiled and is available for inspection by the relevant enforcement authorities.

The CE mark was first applied in: 2006

Product Description: Desk mounted magnifying LED lamp.
Model number(s): SAM170
Serial / batch Number: N/A
Date of Issue: 21/11/2016

Signed:

J.A. Clarke
Director

A SELECTION FROM THE VAST RANGE OF

Clarke®

QUALITY PRODUCTS

AIR COMPRESSORS

From DIY to industrial, Plus air tools, spray guns and accessories.

GENERATORS

Prime duty or emergency standby for business, home and leisure.

POWER WASHERS

Hot and cold, electric and engine driven - we have what you need

WELDERS

Mig, Arc, Tig and Spot. From DIY to auto/industrial.

METALWORKING

Drills, grinders and saws for DIY and professional use.

WOODWORKING

Saws, sanders, lathes, mortisers and dust extraction.

HYDRAULICS

Cranes, body repair kits, transmission jacks for all types of workshop use.

WATER PUMPS

Submersible, electric and engine driven for DIY, agriculture and industry.

POWERTOOLS

Angle grinders, cordless drill sets, saws and sanders.

STARTERS/CHARGERS

All sizes for car and commercial use.



PARTS & SERVICE: 0208 988 7400

E-mail: Parts@clarkeinternational.com or Service@clarkeinternational.com

SALES: UK 01992 565333 or Export 00 44 (0)1992 565335

Clarke® INTERNATIONAL Hemnall Street, Epping, Essex CM16 4LG
www.clarkeinternational.com