

CLARK® weld

MIG WELDER

Model Nos.

195TEC • 205TE • 230TEC



OPERATING & MAINTENANCE
INSTRUCTIONS



0706



WELDER SPECIFICATIONS

PRIMARY or INPUT POWER DATA

	MIG195TEC	MIG205TE	MIG230TEC
Primary Volts	230V/1PH	230V/1PH	230V/1Ph
Primary Amps	24 Amps	24 Amps	28 Amps
Frequency	50 HZ	50 HZ	50Hz

SECONDARY or OUTPUT POWER DATA

	MIG195TEC	MIG205TE	MIG230TEC
Sec. Volts	23-44 V	23-30 V	23-46 V
Max. Sec. Amps	185	185	210
Current Range	30-185	30-185	30-210

DUTY CYCLES

	MIG195TEC	MIG205TE	MIG230TEC
100%	80 Amps	60 Amps	80 Amps
60%	103 Amps	80 Amps	103 Amps
20%	170 Amps	--	--
16%	--	--	200 Amps
12%	--	65 Amps	--

NOTE: Duty Cycles are rated over a 10 minute period.

Example: If welding with a MIG 205TE at 80amps, a 60% duty cycle applies. This means that over a 10 minute period, the welding time is 6 minutes, the down time is 4 minutes.

USABLE WIRE SIZES

	MIG195TEC	MIG205TE	MIG230TEC
Mild Steel Wire	0.6-0.8mm	0.6-0.8mm	0.6-0.8mm
Stainless Steel Wire	0.8mm	0.8mm	0.8mm
Aluminium Wire	0.8mm	0.8mm	0.8mm

USABLE GASES MAIN USES

75% Argon 25% CO ²	- Thin Sheet Metal, Mild Steel
100% Argon	- Welding Aluminium, Stainless Steel
100% CO ²	- Mild Steel

The details and specifications contained herein, are correct at the time of going to print. However, CLARKE International reserve the right to change specifications at any time without prior notice. Consult machines data plate.



When disposing of this product, ensure it is disposed of according to all local ordinances. Do not dispose of with general waste.

CONTENTS

PAGE

Welder Specifications	2	
Parts & Service Contacts	3	
Guarantee	4	
Electromagnetic Interference (EMC)	5	
Safety Precautions	7	
Additional Safety Precautions for MIG Welding	12	
Principles of Operation	14	
Electrical Connections	15	
Unpacking and Parts Identification	16	
Assembly	Attaching the Torch	17
	Installing the Welding Wire	18
	Connecting the Gas Supply	20
	Welding Shield	20
Preparation for Use	Tuning the Welder	21
MIG Welding Operation		21
Wire Specification Chart		22
Welding Tips & Maintenance		22
Troubleshooting		23
Parts Lists and Diagrams		24 - 29
Wiring Diagrams		30 - 31

PARTS AND SERVICE CONTACTS

For Spare Parts and Service, please contact your nearest dealer,
or CLARKE International, on one of the following numbers.

PARTS & SERVICE TEL: 020 8988 7400

PARTS & SERVICE FAX: 020 8558 3622

or e-mail as follows:

PARTS: Parts@clarkeinternational.com

SERVICE: Service@clarkeinternational.com



Thank you for purchasing this CLARKE MIG Welder, designed to operate using a gas cylinder with plain metal welding wire **ONLY**. This is explained in greater detail within the manual.

Before attempting to operate the machine, it is essential that you read this manual thoroughly and carefully follow all instructions given. In doing so you will ensure the safety of yourself and that of others around you, and you can also look forward to the welder giving you long and satisfactory service.

GUARANTEE

This CLARKE product is guaranteed against faulty manufacture for a period of 12 months from the date of purchase. Please keep your receipt as proof of purchase.

This guarantee is invalid if the product is found to have been abused or tampered with in any way, or not used for the purpose for which it was intended.

Faulty goods should be returned to their place of purchase, no product can be returned to us without prior permission.

This guarantee does not effect your statutory rights.

ELECTROMAGNETIC INTERFERENCE (EMC)

Whilst this unit complies with EMC regulations, the user is responsible for installing and using the welding equipment according to the manufacturers instructions. If electromagnetic disturbances are detected then it shall be the responsibility of the user of the welding equipment to resolve the situation. In some cases this remedial action may be as simple as earthing the welding circuit, see 'Note'. In other cases it could involve constructing an electromagnetic screen enclosing the power source and the work complete with associated input filters. In all cases electromagnetic disturbances must be reduced to the point where they are no longer troublesome.

Note - The welding circuit may or may not be earthed for safety reasons. Changing the earthing arrangements should only be authorised by a person who is competent to assess whether the changes will increase the risk of injury, e.g. by allowing parallel welding current return paths which may damage the earth circuits of other equipment.

1. ASSESSMENT OF AREA

Before installing welding equipment the user shall make an assessment of potential electromagnetic problems in the surrounding area. Avoid using your inverter in the vicinity of:

- a) other supply cables, control cables, signalling and telephone cables; above, below and adjacent to the welding equipment;
- b) radio and television transmitters and receivers;
- c) computer and other control equipment;
- d) safety critical equipment, e.g. guarding of industrial equipment;
- e) pacemakers and hearing aids etc.;
- f) equipment used for calibration or measurement;
- g) other equipment in the environment. The user shall ensure that other equipment being used in the environment is compatible. This may require additional protection measures;

It may be possible to avoid the above by changing the time of day that welding or other activities are to be carried out.

The size of the surrounding area to be considered will depend on the structure of the building and other activities that are taking place. The surrounding area may extend beyond the boundaries of the premises.

2. METHODS OF REDUCING EMISSIONS

2.1 Mains supply

Welding equipment should be connected to the mains supply according to the manufacturers recommendations. If interference occurs, it may be necessary to

take additional precautions such as filtering of the mains supply. Consideration should be given to shielding the supply cable of permanently installed welding equipment, in metallic conduit or equivalent. Shielding should be electrically continuous throughout its length. The shielding should be connected to the welding power source so that good electrical contact is maintained between the conduit and the welding power source enclosure.

2.2 Maintenance of the welding equipment

The welding equipment should be routinely maintained according to the manufacturers recommendations. All access and service doors and covers should be closed and properly fastened when the welding equipment is in operation. The welding equipment should not be modified in any way except for those changes and adjustments covered in the manufacturers instructions. In particular, the spark gaps of arc striking and stabilizing devices should be adjusted and maintained according to the manufacturers recommendations.

2.3 Welding cables

The welding cables should be kept as short as possible and should be positioned close together, running at or close to the floor level.

2.4 Equipotential bonding

Bonding of all metallic components in the welding installation and adjacent to it should be considered. However, metallic components bonded to the work piece will increase the risk that the operator could receive a shock by touching these metallic components and the electrodes at the same time. The operator should be insulated from all such bonded metallic components.

2.5 Earthing of the workpiece

Where the workpiece is not bonded to earth for electrical safety, nor connected to earth because of its size and position, e.g. ships hull or building steelwork, a connection bonding the workpiece to earth may reduce emissions in some, but not all instances.

Care should be taken to prevent the earthing of the workpiece increasing the risk of injury to users, or damage to other electrical equipment.

Where necessary, the connection of the workpiece to earth should be made by a direct connection to the workpiece, but in some countries where direct connection is not permitted, the bonding should be achieved by suitable capacitance, selected according to national regulations.

2.6 Screening and shielding

Selective screening and shielding of other cables and equipment in the surrounding area may alleviate problems of interference. Screening of the entire welding installation may be considered for special applications.

SAFETY PRECAUTIONS FOR ALL TYPES OF WELDING

1. WARNING:

As with all machinery, there are certain hazards involved with their operation and use. Exercising respect and caution will considerably lessen the risk of personal injury. However, if normal safety precautions are overlooked, or ignored, personal injury to the operator may result.

FAILURE TO FOLLOW THESE RULES MAY RESULT IN SERIOUS PERSONAL INJURY

2. GENERAL PRECAUTIONS

A) Burn prevention

Wear protective clothing - gauntlet gloves designed for use in welding, apron, and protective shoes. Button shirt collar and pocket flaps, and wear cuffless trousers to avoid entry of sparks and slag. Wear helmet with safety goggles or glasses with side shields underneath, appropriate filter lenses or plates (protected by clear cover glass). This is a MUST for welding or cutting, (and chipping) to protect the eyes from radiant energy and spatter. Replace cover glass when broken, pitted, or spattered. Avoid oily greasy clothing. A spark may ignite them. Hot metal such as electrode stubs and workpieces should never be handled without gloves. First aid facilities and a qualified first aid person should be available unless medical facilities are close by for immediate treatment of flash burns of the eyes and skin burns. Ear plugs should be worn when working overhead or in a confined space. A hard hat should be worn when others work overhead. Flammable hair preparations should not be used by persons intending to weld or cut.

B) Toxic fume prevention

Severe discomfort, illness or death can result from fumes, vapours, heat, or oxygen enrichment or depletion that welding (or cutting) may produce. Prevent them with adequate ventilation. NEVER ventilate with oxygen. Lead-, cadmium-, zinc-, mercury- and beryllium-, bearing materials, when welded (or cut) may produce harmful concentrations of toxic fumes. Adequate local exhaust ventilation must be used, or each person in the area as well as the operator must wear an air-supplied respirator. For beryllium, both must be used. Metals coated with or containing materials that emit toxic fumes should not be heated unless coating is removed from the work surface, the area is well ventilated, or the operator wears an air-supplied respirator. Work in a confined space only while it is being ventilated and, if necessary, while wearing an air-supplied respirator. Vapours from chlorinated solvents can be decomposed by the heat of the arc (or flame) to form PHOSGENE, a highly toxic gas, and other lung and eye irritating products. The ultraviolet (radiant) energy of the arc can also decompose trichloroethylene and perchloroethylene vapours to form phosgene. DO NOT WELD or cut where solvent vapours can be drawn into the welding or cutting atmosphere or where the radiant energy can penetrate to atmospheres containing even minute amounts of trichloroethylene or perchloroethylene.

C) Fire and explosion prevention

Causes of fire and explosion are:

- 1) combustibles reached by the arc, flame, flying sparks, hot slag or heated material;
- 2) misuse of compressed gases and cylinders;
- 3) short circuits.

BE AWARE THAT flying sparks or falling slag can pass through cracks, along pipes, through windows or doors, and through wall or floor openings, out of sight of the goggled operator. Sparks and slag can fly 10M.

To prevent fires and explosion: keep equipment clean and operable, free of oil, grease, and (in electrical parts) of metallic particles that can cause short circuits. If combustibles are in area, do NOT weld or cut. Move the work if practicable, to an area free of combustibles.

Avoid paint spray rooms, dip tanks, storage areas, ventilators. If the work cannot be moved, move combustibles at least 10M, away out of reach of sparks and heat; or protect against ignition with suitable and snug fitting, fire-resistant covers or shields.

Walls, ceilings, and floor near work should be protected by heat resistant covers or shields. Fire watcher must be standing by with suitable fire extinguishing equipment during and for some time after welding or cutting if:

- a) appreciable combustibles (including building construction) are within 10m.
- b) appreciable combustibles are further than 10m but can be ignited by sparks.
- c) openings (concealed or visible) in floors or walls within 10m can expose combustibles to sparks.
- d) combustibles adjacent to walls, ceilings, roofs or metal partitions can be ignited by radiant or conducted heat.

After work is done, check that area is free of sparks, glowing embers, and flames. An empty container that held combustibles, or that can produce flammable or toxic vapours when heated, must never be welded on or cut, unless container has first been cleaned. This includes.....a thorough steam or caustic cleaning (or a solvent or water washing, depending on the combustible's solubility) followed by purging and inerting with nitrogen or carbon dioxide, and using protective equipment.

Water filling just below working level may substitute for inerting.

A container with unknown contents should be cleaned (see paragraph above), do NOT depend on sense of smell or sight to determine if it is safe to weld or cut.

Hollow castings or containers must be vented before welding or cutting - they can explode.

In explosive atmospheres, never weld or cut where the air may contain flammable dust, gas, or liquid vapours.

3. ELECTRIC ARC (MIG, TIG) WELDING

Comply with precautions in 1 above, and this section. Arc welding, properly done, is a safe process, but a careless operator invites trouble. The equipment carries high currents at significant voltages. The arc is very bright and hot. Sparks fly, fumes rise, ultraviolet and infrared energy radiates, weldments are hot. The wise operator avoids unnecessary risks and protects himself and others from accidents.

3A) BURN PROTECTION

Comply with precautions in 2. The welding arc is intense and visibly bright. Its radiation can damage eyes, penetrate lightweight clothing, reflect from light coloured surfaces, and burn the skin and eyes. Skin burns resemble acute sunburn, those from gas - shielded arcs are more severe and painful.

DON'T GET BURNED! COMPLY WITH PRECAUTIONS!

1) Protective clothing

Wear long sleeved clothing (particularly for gas shielded arc) in addition to gloves, apron and shoes (2A). As necessary, use additional protective clothing such as leather jacket or sleeves, flameproof apron, and fire-resistant leggings. Avoid outer garments of untreated cotton. **Bare skin protection:** Wear dark substantial clothing, Button collar to protect chest and neck and button pockets to prevent entry of sparks.

2) Eye and head protection

Protect eyes from exposure to arc. NEVER look at an electric arc without protection. Welding helmet or shield containing a filter plate shade no. 12 or denser must be used when welding. Place over face before striking arc. Protect filter plate with a clear cover plate. Cracked or broken helmet or shield should NOT be worn; radiation can pass through to cause burns. Cracked, broken, or loose filter plates must be replaced IMMEDIATELY. Replace clear cover plate when broken, pitted, or spattered. WE SUGGEST you wear flash goggles with side shields under the helmet, to give some protection to the eyes should the helmet not be lowered over the face before an arc is struck. Looking at an arc momentarily with unprotected eyes (particularly a high intensity gas-shielded arc) can cause a retinal burn that may leave a permanent dark area in the field of vision. Before welding whilst wearing contact lenses, seek advice from your optician.

3) Protection of nearby personnel

For production welding, a separate room or enclosed bay is best. In open areas, surround the operation with low reflective, non-combustible screens or panels. Allow for free air circulation, particularly at floor level. Provide face shields for all persons who will be looking directly at the weld. Others working in the area should wear flash goggles. Before starting to weld, make sure that screen or bay doors are closed.

3B) TOXIC FUME PREVENTION

Comply with precautions in 2B. Generator engine exhaust must be vented to the outside air. Carbon monoxide can kill.

3C) FIRE AND EXPLOSION PREVENTION

Comply with precautions in 2C. Equipment's rated capacity. Do not overload arc welding equipment. It may overheat cables and cause a fire. Loose cable connections may overheat or flash and cause a fire. Never strike an arc on a cylinder or other pressure vessel. It creates a brittle area that can cause a violent rupture or lead to such a rupture later under rough handling.

3D) SHOCK PREVENTION

Exposed live conductors or other bare metal in the welding circuit, or in unearthed, electrically-LIVE equipment can fatally shock a person whose body becomes a conductor. DO NOT STAND, SIT, LIE, LEAN ON, OR TOUCH a wet surface when welding, without suitable protection.

3E) PROTECTION FOR WEARERS OF ELECTRONIC LIFE SUPPT DEVICES (PACEMAKERS)

Magnetic fields from high currents can affect pacemaker operation. Persons wearing electronic life support equipment (pacemaker) should consult with their doctor before going near arc welding, gouging, or spot welding operations.

3F) TO PROTECT AGAINST SHOCK:

Keep body and clothing dry. Never work in damp area without adequate insulation against electrical shock. Stay on a dry duckboard, or rubber mat when dampness or sweat can not be avoided. Sweat, sea water, or moisture between body and an electrically LIVE part - or earthed metal - reduces the body surface electrical resistance, enabling dangerous and possibly lethal currents to flow through the body.

1) Earthing the equipment

When arc welding equipment is earthed according to the National Electrical Code, and the workpiece is earthed, a voltage may exist between the electrode and any conducting object.

Examples of conducting objects include, but are not limited to, buildings, electrical tools, work benches, welding power source cases, workpieces, etc. Never touch the electrode and any metal object unless the welding power source is off. When installing, connect the frames of each unit such as welding power source, control, work table, and water circulator to the building earth.

Conductors must be adequate to carry earth currents safely. Equipment made electrically LIVE by stray current may shock, possibly fatally. Do NOT EARTH to electrical conduit, or to a pipe carrying ANY gas or a flammable liquid such as oil or fuel.

2) Electrode holders

Fully insulated electrode holders should be used. Do NOT use holders with protruding screws or with any form of damage.

3) Connectors

Fully insulated lock-type connectors should be used to join welding cable.

4) Cables

Frequently inspect cables for wear, cracks and damage. IMMEDIATELY REPLACE those with excessively worn or damaged insulation to avoid possibly lethal shock from bared cable. Cables with damaged areas may be taped to give resistance equivalent to original cable. Keep cable dry, free of oil and grease, and protected from hot metal and sparks.

5) Terminals and other exposed parts

Terminals and other exposed parts of electrical units should have insulating covers secured before operation.

6) Electrode

a) Equipment with output on/off control (contactor)

Welding power sources for use with the gas metal arc welding, gas tungsten arc welding and similar processes normally are equipped with devices that permit on/off control of the welding power output. When so equipped the electrode wire becomes electrically LIVE when the power source switch is ON and welding gun switch is closed. Never touch the electrode wire or any conducting object in contact with the electrode circuit unless the welding power source is off.

b) Equipment without output on/off control (no contactor)

Welding power sources used with shielded metal arc welding and similar processes may not be equipped with welding power output on/off control devices. With such equipment the electrode is electrically LIVE when the power switch is turned ON. Never touch the electrode unless the welding power source is off.

7) Safety devices

Safety devices such as interlocks and circuit breakers should not be disconnected or shunted out. Before installation, inspection, or service of equipment, shut OFF all power and remove line fuses (or lock or red-tag switches) to prevent accidental turning ON of power. Do not open power circuit or change polarity while welding. If, in an emergency, it must be disconnected, guard against shock burns, or flash from switch arcing. Always shut OFF and disconnect all power to equipment. Power disconnect switch must be available near the welding power source.

PREPARATION OF THE WORKING AREA

The working area must be sufficiently spacious, not humid, and well-ventilated as to avoid any fumes which develop from the welding process and from incidental material adhering to the pieces to be welded (oils, paints, tars...) which may cause annoyance to the operator.

Avoid welding by contact with humid parts nearby combustible liquids. Least of all, do not weld upon tanks which may contain flammable residuals.

ADDITIONAL SAFETY PRECAUTIONS for MIG WELDING

- ✓ **ALWAYS** ensure that there is full free air circulating around the outer casing of the machine, and that the louvres are unobstructed.
- ✓ Welding arc can seriously damage your eyes. Both operator and spectators must **ALWAYS** use a proper welding face shield or helmet, with suitable filter lenses. Proper gloves and working clothes should be worn at all times.
- ✓ **ALWAYS** check that the pressure regulator and gauges (where fitted), are working correctly. DO NOT lubricate the regulator.
- ✓ **ALWAYS** use the correct regulator. Regulators are designed to be used with a specific gases.
- ✓ **ALWAYS** inspect the hose before use to ensure it is in good condition.
- ✓ **ALWAYS** keep the free length of gas hose outside the work area.
- ✓ **ALWAYS** remove all flammable materials from the welding area.
- ✓ **ALWAYS** Keep fire extinguisher handy.... **Dry Powder, CO₂ or BCF, NOT Water**
- ✗ **NEVER** remove any of the panels unless the machine is disconnected from the supply, AND never use the machine with any of the panels removed.
- ✗ **NEVER** attempt any electrical or mechanical repair unless your are a qualified technician. If you have a problem with the machine contact your local CLARKE dealer.

- X NEVER** use or store in a wet/damp environment. DO NOT EXPOSE TO RAIN.
- X** The MIG welding process uses an INERT gas to protect the weld pool. It is important to ensure the appropriate gas is being used. **NEVER** use gas from a cylinder, the content of which is unknown.
- X NEVER**
 - a. Use a damaged cylinder.
 - b. Lift the cylinder by the valve.
 - c. Expose the cylinder to a heat source or sparks.
- X NEVER** continue to weld, if, **at any time**, you feel even the smallest electric shock. Stop welding IMMEDIATELY, and DO NOT attempt to use the machine until the fault is diagnosed and corrected.
- X NEVER** point the MIG torch at any person or animal.
- X NEVER** touch the MIG torch nozzle until the welder is switched OFF and the nozzle has been allowed to cool off.
- X NEVER** connect, disconnect, or attempt to service the MIG torch, until the machine is switched OFF and disconnected from the mains supply.
- X NEVER** allow the cables to become wrapped around the operator or any person in the vicinity.

DANGER - ELECTRIC SHOCK CAN BE FATAL.

A person qualified in first aid should always be present in the working area. If person is unconscious and electric shock is suspected, do not touch the person if he or she is in contact with the welder or cables. Disconnect the welder from the power source and then use First Aid. Dry wood, or other insulating material can be used to move cables, if necessary, away from the person.

SAFETY EQUIPMENT

A comprehensive range of CLARKE safety equipment for use when welding is available from your local dealer.

MIG WELDING - PRINCIPLES OF OPERATION

MIG (Metal Inert Gas) welding is a process in which a power wire electrode is fed continuously into the weld pool at a controlled, constant rate.

The wire is connected to the positive side of a rectified voltage supply. The workpiece is connected to the negative side of the supply.

When the wire is fed, it comes into contact with the workpiece and an arc is struck. The arc melts the wire and the material, fusing it together.

The wire, which is fed by the wire feed motor is fed into the weld pool, burning itself off at a rate dependent upon the selected wire feed speed.

To protect the weld pool from oxidation and impurities during the welding process, a shielding gas flows over and around the weld pool. This gas flow must be sufficient to protect the weld, but not wasteful.

NOTE: *Poor gas coverage will result in poor welding. Excessive gas coverage is wasteful and expensive.*

BENEFITS OF MIG WELDING

1. 50% faster welding time.
2. Operator training time kept to a minimum.
3. There is no slag removal, thus eliminating almost all post-welding cleaning operations.
4. Minimum waste of welding consumables.
5. Overall, a faster more efficient way of getting the job done.
6. Less heat - less distortion.
7. Ability to weld thin material.

ELECTRICAL CONNECTIONS

WARNING: THIS MACHINE MUST BE EARTHED.

This welder must be connected to a 230 volt (50Hz) supply, having a rated capacity of greater than 13 amps.

A 13 Amp (BS1363) plug is not suitable for this device.

Connect the three core mains lead to a suitably fused supply through an isolator or heavy duty plug.

IMPORTANT: The wires in the mains lead are coloured in accordance with the following colour code:

Green & Yellow - Earth
Blue - Neutral
Brown - Live

- Connect GREEN & YELLOW coloured cord to plug terminal marked with a letter "E" or Earth symbol .
- Connect BROWN coloured cord to plug terminal marked letter "L"
- Connect BLUE coloured cord to plug terminal marked letter "N"

We strongly recommend that this machine is connected to the mains supply through a Residual Current Device.

IMPORTANT: If in doubt, consult a qualified electrician. Do not attempt any electrical repairs yourself.

UNPACKING & PARTS IDENTIFICATION

1. The side panel is hinged at its rear edge: Open by pulling sideways at the front edge, lay out all components contained within, and check to ensure that they are all correct according to the list below.

- A 2 Wheels
- B 1 Axle
- C 2 Wheel retaining washers
- D 2 Casters
- E 1 Handle
- F 2 Fixing screws

Fig.1

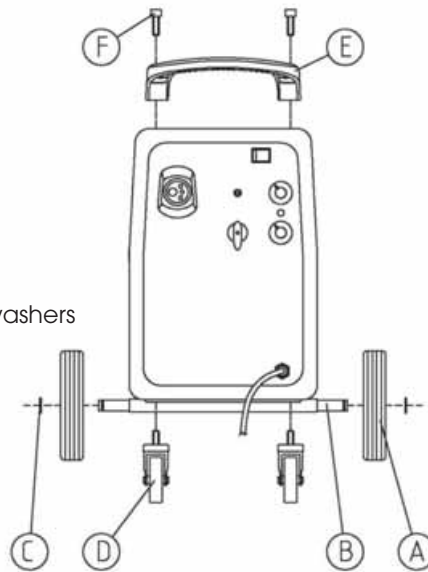

Loose Items - not shown

- 1 x Mask with fixing screws and washers
- 1 x Mask handle
- 2 x Handle retaining screws
- 1 x Transparent glass
- 1 x Dark glass
- 1 x 0.6mm welding tip
- 1 x 0.8mm welding tip
- 1 x 1.0mm welding tip
- 1 x Gas regulator
- 2 x Worm drive clips for gas hose connections (1 only for MIG 230TEC)
- 1 x Welding torch and lead
- 1 x Plastic cover for hose support bracket (MIG195TEC & 205TE only)
- 2 x Self tapping screws for cover (MIG195TEC & 205TE only)

SHOULD ANY PART BE MISSING OR DAMAGED, CONTACT YOUR LOCAL DEALER FOR REPLACEMENT.

2. Slot the axle (B) through the holes at the rear of the machine and slide a wheel (A) on to each end followed by the retaining washers.
3. Screw the two casters (D) to the machine.
4. Attach handle to the top of the machine, using the two screws provided.

ASSEMBLY

A. Attaching the Torch

Mig 195TEC - Mig 205TE

- A. It is necessary to fit the torch hose assembly (7) to the machine, but before doing so you must first measure the length of protrusion of the liner (9) from the brass nut (10).

IMPORTANT:

This measurement should be a maximum of 18mm and should be carefully trimmed to this length using a good pair of side cutters, or similar, ensuring there are no burrs or sharp edges which may impede the progress of the wire when fitted.

- B. Having checked the protrusion of the liner, and trimmed where necessary remove the nut (1) and the washer (2) from the end of the torch assembly (7). Carefully feed the hose assembly through the hole in the front face of the welder (16), taking care to feed the electrical connectors (11-14) through at the same time. Continue to feed the hose assembly through the brass collar (5) in the bracket assembly (4).
- C. You will notice a large ring terminal (3) roughly in position to be threaded on the end of the hose assembly, as it appears through the brass collar (5) in the bracket assembly (4). Thread the terminal on the hose assembly, followed by the washer (2) and screw on the nut (1) which should then be carefully tightened.

Note: when correctly assembled, the wire liner (9) must not be in contact with the wire feed roller (8).

- D. Fit the plastic cover (15) over the complete assembly, securing with the two self-tapping screws provided.
- E. Connect the gas hose (12) to the gas hose nipple (6) securing with the worm drive clip (13) provided.
- F. Make the electrical connections by joining connectors (11-14)

Note: The connectors are one-way fit, and simply clip together - do not use excessive force.

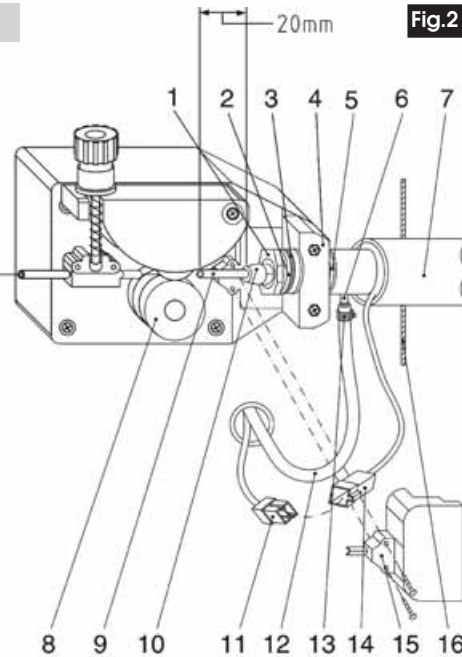

Mig 230TEC

Plug the torch hose into the socket on the front of the welder and secure by hand screwing in the threaded connection.

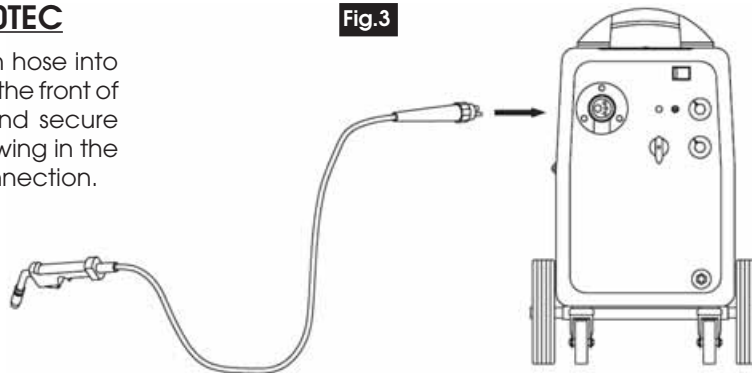

B. Loading the Wire

NOTE: These machines are designed to accept either the Clarke 5kg or 15kg wire spools of mild steel, stainless steel or aluminium according to the type of metal you wish to weld. Wire spools must be purchased separately. See your Clarke dealer for full details.

1. **IMPORTANT:** Ensure that the gas and electrical supplies are disconnected.
2. To fit the wire spool, firstly open the side compartment by pulling the recessed catch backwards.
3. Turn the plastic knob with cam (7) to the position shown in Fig. 4, i.e. with the flat uppermost, so that the latch is unlocked, and pull off the collar (6).
4. Slide the spool on to the shaft, ensuring that the Peg 'A' locates snugly in locating hole 'B', ensuring the direction of feed of the wire is in the direction of the arrow.

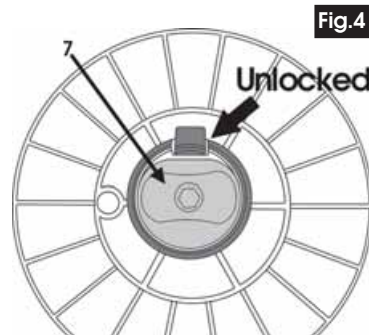

Replace the collar - 4, (5kg spool ONLY), and turn the Plastic knob with cam (7) through 180 degrees, to the position shown in Fig.6 thereby locking the spool on the shaft.

1. Pressure plate
2. Mounting Shaft
3. Wire Spool
4. Collar
5. Flat Washer
6. Spring

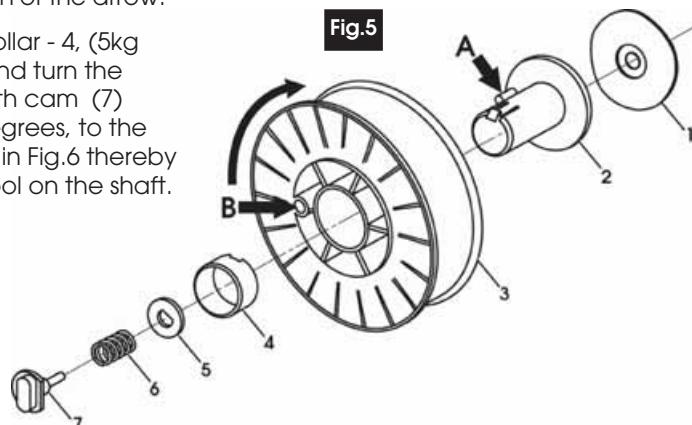

NOTE: The Plastic knob, item 7 is also used to apply slight tension to the wire spool. This prevents the spool from running freely, which could cause the wire to unspool, creating a 'birds nest' tangle within the side compartment. Adjust by hand and test the tension.

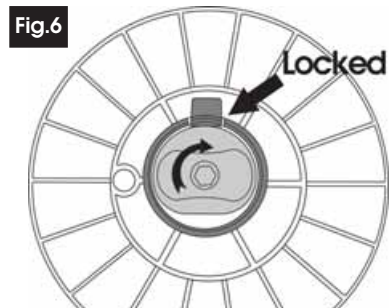

It is now necessary to load the wire into the Torch...as follows:

- Loosen the plastic knob (17, Fig.2) by turning it anticlockwise, (this maintains pressure on the wire via the roller). Pull on the plastic knob, so that the screw rod comes out of its slot, thereby releasing the pivoted roller bracket. Raise the bracket together with the pressure roller. Check to ensure there is no wire in the liner, if there is...pull it out and discard.
- Ensure the Wire roller is set so that the appropriate groove - 6mm or 8mm, is in place, i.e. in line with the wire liner.
To change to the other groove, undo the Hex. socket securing screw and remove the roller from its shaft. Turn it through 180°, replace it on the shaft, and adjust so that the groove is directly in line with the Wire Liner. Firmly secure it in that position with the Hex. Socket Screw.
- Clip the end of the wire, on the spool, cleanly, ensuring there are no burrs or sharp edges, and, ensuring it is straight, feed it through the guide tube, over the channel on the roller and into the wire liner, by approx. 10 - 15cm.
- Reposition the pressure roller and plastic knob and tighten slightly.

IMPORTANT: Too tight will crush the wire and damage the wire feed motor, too loose will not allow the wire to be pulled by the roller.

- Pull off the torch shroud by twisting it clockwise, and unscrew the contact tip. Close the side panel of the machine, plug into a 230V, 50HZ outlet (or switch on isolator), switch on the machine and press the trigger. The wire will feed through the hose and when it appears at the torch end, release the trigger, switch off the machine and replace the contact tip and the torch shroud.

IMPORTANT: Ensure the hose is kept straight during this operation, to assist the wire as it is feed through to the nozzle.

C. Gas Supply

It is necessary to procure a cylinder of gas, suitable for the job in hand.

Locate the gas cylinder on the platform at the rear of the unit, and secure using the chain provided.

A regulator is provided, complete with outlet pressure gauge for use with argon or argon mix gas bottles. Should you require to use Carbon Dioxide, it will be necessary for you to purchase an appropriate regulator with a female connector. Your Clarke dealer will be happy to advise in this regard.

Ensure the outlet of the gas bottle is clean, then screw on the regulator and tighten.

Always use the appropriate gas for the material being welded. If you are unsure, consult a qualified tradesman, or a suitable reference book.

Attach the nut and tail to the gas hose, using the worm drive clip provided, then screw the nut on to the regulator outlet and tighten.

Open the gas valve and screw in the regulator knob to allow gas into the system to check for gas leaks. If any are apparent, they must be rectified before proceeding.

Turn off the gas when satisfied the system is leak free.

D. Face Shield

To assemble the welding shield, insert the clear glass panel first, followed by the dark glass panel into the recess in the shield, i.e. the clear glass **MUST** be on the outside of the shield. Securing them with the plastic screws provided.

Slot the two pieces together as shown, and enter the threaded end of the handle through the holes provided. Thread on the plastic nut and tighten.

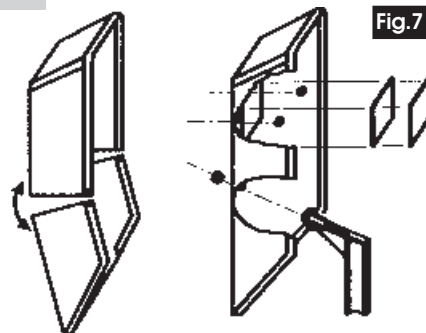

Always maintain the welding mask in good condition. If the clear glass protection lens becomes badly pitted, sufficient to interfere with vision, or cracked, have it replaced immediately. Replacement clear and dark lenses are available from your Clarke dealer - see Parts Lists for details. NEVER use any dark filter lens other than that provided by CLARKE International, or one with the same certified 'Optical class' (degree of protection).

The shield should always be cleaned with a clean soft cloth after use, ensuring the lenses are clean. Remove any dust that may have accumulated and store it in a safe place where it cannot be damaged. NEVER use a shield that is **not** in perfect condition.

The clear glass panel should be replaced when it becomes badly pitted.

WARNING:

NEVER look at an electric arc without eye protection as this can injure the eyes permanently. ALWAYS use a protection mask or welding helm

PREPARATION FOR WELDING

1. Attach the earth clamp to the bare metal to be welded. Ensure contact is good .
2. Make sure that the wire-roller groove in the roller corresponds to the diameter of the welding wire being used. Refer to "Loading wire" above.
3. Plug the machine into a 230V AC 50Hz outlet.
4. Open the gas valve on the gas cylinder regulator, (turn knob clockwise)and adjust the gas regulator to the proper setting position. NOTE: this varies with different metals, thicknesses and currents. Refer to a MIG welding manual for instructions.

TUNING THE WELDER

The tuning of a Mig welding machine requires some practice, due to the fact that - contrary to the arc welding procedure - two parameters must be accommodated to achieve a perfect weld. These are:

(A) Wire Feed Speed, and (B) Welding Voltage.

It is important to arrive at the correct combination to suit the type and thickness of material to be welded. **The current necessary for welding is directly dependent upon the wire feed speed.**

If the wire feed speed is increased, the current is also increased, but the arc length is decreased. Conversely, if the wire feed speed is decreased, and current is therefore decreased, the length of arc is increased.

Increase of the welding voltage leads to a longer arc (without substantially affecting the current). Conversely, a decreased welding voltage results in a shorter arc, (the current again is not substantially changed).

A change in wire diameter results in changed parameters. A smaller diameter wire requires an increase in wire feed speed to reach the same current. If certain limits are exceeded, a satisfactory weld cannot be obtained. These are:

- A) A too high wire feed speed (too high with regard to the welding voltage) results in pulsing within the torch. This is because the wire electrode dips into the puddle and cannot be melted off fast enough.
- B) If the welding voltage is set too high, large drops can be seen at the end of the wire electrode. These drops are often deposited beside the welding seam.

The correct rate of wire feed speed (current) and welding voltage, results in very little spatter and a continuous, intensive hissing can be heard from the arc.

OPERATION

1. These machines have 6 welding positions (see the table below) in which to regulate current for various conditions.
2. The selection of a welding position is determined by the thickness of the metal to be welded. The thicker it is, the higher the current must be.
3. According to the thickness to be welded, the amount of gas regulated to the work also varies and must be adjusted accordingly.
4. For welding adjustments, refer to the table below.

WARNING

- (i) Make sure all flammable materials are removed from the work area.
- (ii) Never look directly at the welding arc, it can seriously damage your eyes. Always use an approved welding mask or helmet.
- (iii) Wear protective clothing so that all skin areas are covered.
- (iv) Keep a fire extinguisher handy.

WIRE SIZE SPECIFICATION CHART

		STEEL WIRE DIAMETER (mm)	WIRE SPEED ADJUSTMENT
SWITCH POSITIONS	1	0.6	LOW
	2	0.6	LOW
	3	0.6 - 0.8	MEDIUM
	4	0.6 - 0.8	MEDIUM
	5	0.8	MEDIUM - HIGH
	6	0.8	HIGH

WELDING TIPS AND MAINTENANCE

1. Always weld clean, dry and well prepared material.
2. Hold gun at a 45° angle to the workpiece with nozzle about 6mm from the surface.
3. Move the gun smoothly and steadily as you weld.
4. Avoid welding in very draughty areas. A weak pitted and porous weld will result due to air blowing away the protective welding gas.
5. Keep wire and wire liner clean. Do not use rusted wire.
6. Sharp bends or kinks on the welding hose should be avoided.
7. Always try to avoid getting particles of metal inside the machine since they could cause short circuits.
8. If available, use compressed air to periodically clean the hose liner when changing wire spools.
IMPORTANT: Disconnect from power source when carrying out this operation.
9. Using low pressure air (20-30 PSI), occasionally blow the dust from the inside of the welder. This keeps the machine running cooler. Note: do not blow air over the printed circuit board and electronic components.
10. The wire feed roller will eventually wear during normal use. With the correct tension the pressure roller must feed the wire without slipping. If the pressure roller and the wire feed roller make contact (when the wire is in place between them), the wire feed roller must be replaced.
11. Check all cables periodically. They must be in good condition and not cracked.

TROUBLE SHOOTING

PROBLEM	PROBABLE CAUSE	REMEDY
1. No life from welder	Check fuses and mains lead	a) Replace fuses as necessary. If problem persists, return welder to your local dealer. b) Check fuse size.
2. No wire feed	Motor malfunction	Return welder to your local dealer.
3. Feed motor operates but wire will not feed	a) insufficient feed roller pressure b) Burr on end of wire c) Liner blocked/damaged d) Inferior wire	a) Increase roller pressure b) Re-cut wire square c) Clear with compressed air or replace liner. d) Use only good clean wire
4. Wire welds itself to tip	a) Wirefeed speed too low b) Wrong size tip	a) Unscrew tip cut wire and fit new tip. Increase wire speed before operating again. b) Change tip size.
5. Wire feeds into birds nest tangle.	a) Wire welded to tip. b) Wire liner damaged preventing smooth operation.	a) As above plus reduce feed roller pressure so if blockage occurs wire sleeps on roller. i.e. no feed b) Renew wire liner.
6. Tangled coils of wire around drum	Drum brake too slack.	Tighten drum brake DO NOT OVERTIGHTEN
7. Erratic wire feed	a) Drum brake too light b) Feed roller worn c) Insufficient pressure on feed roller d) Wire dirty, rusty, damp or bent e) Liner partially blocked	a) Loosen drum brake slightly b) Check and replace if necessary c) Increase pressure on feed roller DO NOT OVER TIGHTEN d) Re-cut wire and ensure it is clean e) Clear with compressed air
8. Poor quality welds	a) Insufficient gas at weld area b) Incorrect gas/wire combination c) Rusty, painted, damp, oily or greasy work piece d) Rusty, dirty work. e) Poor earth contact	a) Check gas is not being blown away by draughts, if so, move to a sheltered area. If no draught, increase gas supply. b) Consult Mig Welding manual c) Ensure wkpiece is clean and dry d) Ensure wire is clean and dry e) Check ground clamp/ wkpiece connection.
9. Wire jams in tip when welding aluminium	Tip too small	Use slightly oversize tip i.e. for 0.8mm wire use 1mm tip (Applies to aluminium only)
10. Welder cuts out whilst in use	Duty Cycle exceeded (auto cut-out operates)	Allow welder to cool for 10-30min before continuing. Note: If duty cycle is continually exceeded, damage to welder may result and welder output is probably too small for application,

PARTS DRAWING - MIG 195TEC

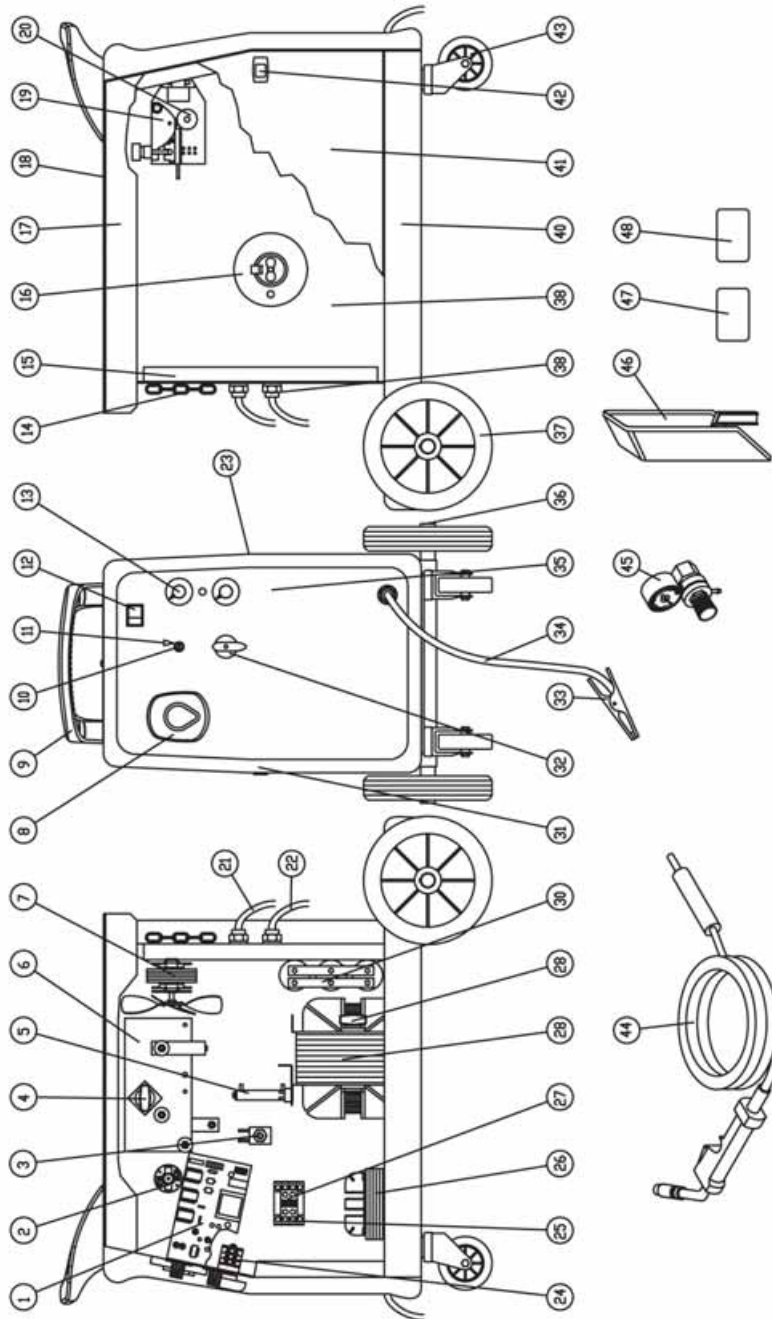

PARTS LIST - MIG 195TEC

No.	Description	Qty	Part No:
01	Motor Contr. PCB	1	EM22710048
02	Motor	1	EM04600156
02	Motor Brush For Motor D.48	2	EM22810064
03	Gas Solenoid Valve 4W 220V 50Hz	1	EM22900001
04	Complete Thermostat + Support	1	EM04600113
05	Resistance 3 Ohm D.16	1	EM22305004
06	Rectifer Pins 16/4/2 F	1	EM22400009
07	Fan C20 220V	1	EM22800002
08	Direct Torch Connection Cover	1	EM21690268
09	Handle	1	EM21600042
10	Fuse Holder Ptf/35 6,3A 250v	1	EM22220016
11	Fuse 5x20 T1A250V	1	EM22220002
12	On/off Switch 1 6A-250V	1	EM22200002
13	Potentiometer Knob	2	EM21690309
14	Zinc Chain Nr 17 Nm 3,1 L=0,76 Mt	1	EM04600205
15	Rear Panel	1	EM33715091
16	Complete Spool Holder D.50	1	EM04600001
17	Cover Panel	1	EM33705449
18	Holder Mat x1 80x536	1	EM30905021
19	Plastic Wire Feeder D.48 Rolls 06-08	1	EM44400003
20	Wire Feed Roll D.9x30 0,6-0,8mm Knurled	1	EM33805023
21	Black Hose D.5x10,5	1	EM30900027
22	Pvc Input Cable 3x2,5 M.2,5	1	EM20220020
23	Right Panel	1	EM33705292
24	Switch 16A CM 16	1	EM22205016
25	Contacteur 220V 1CA	1	EM22225006
26	Choke D.6 50x50 Al	1	EM44135126
27	Auxiliary Contacts	1	EM22225018
28	Thermostat 16A	1	EM22210016
28	Transformer 1 ph 230V 45x90 Al	1	EM44120053
30	Capacitor 12000 Mf 63V 50x80	1	EM22315002
31	Plastic Front Frame	3	EM21690234
32	Swicth Knob D.38	1	EM21690312
33	Earth Clamp 150-200A	1	EM22110007
34	Earth Cable 16mm2	1	EM43210010
35	Front Panel	1	EM33710306
36	Wheels Axle D.20	1	EM55200030
37	Wheel D. 180 Rubber	2	EM21625040
38	Cable Clamp For Hole D.20	3	EM21605010
40	Lower Panel	1	EM33720088
41	Side Panel	1	EM33700161
42	Slide Clip	1	EM33705391
43	Rubber Pivoting Wheel D.85	1	EM21690226
44	Torch Plus 14 M 3 Direct Connection	2	EM21625002
45	Reducer Mini 1/gauge	1	EM23000324
46	Carton Mask 82x108	1	EM22905004
47	Transparent Glass 82x1 08	1	EM21905019
48	Dark Glass 82x108	1	EM21905020
49	Dark Glas 42x108	1	EM21905021

PARTS DRAWING - MIG 205TE

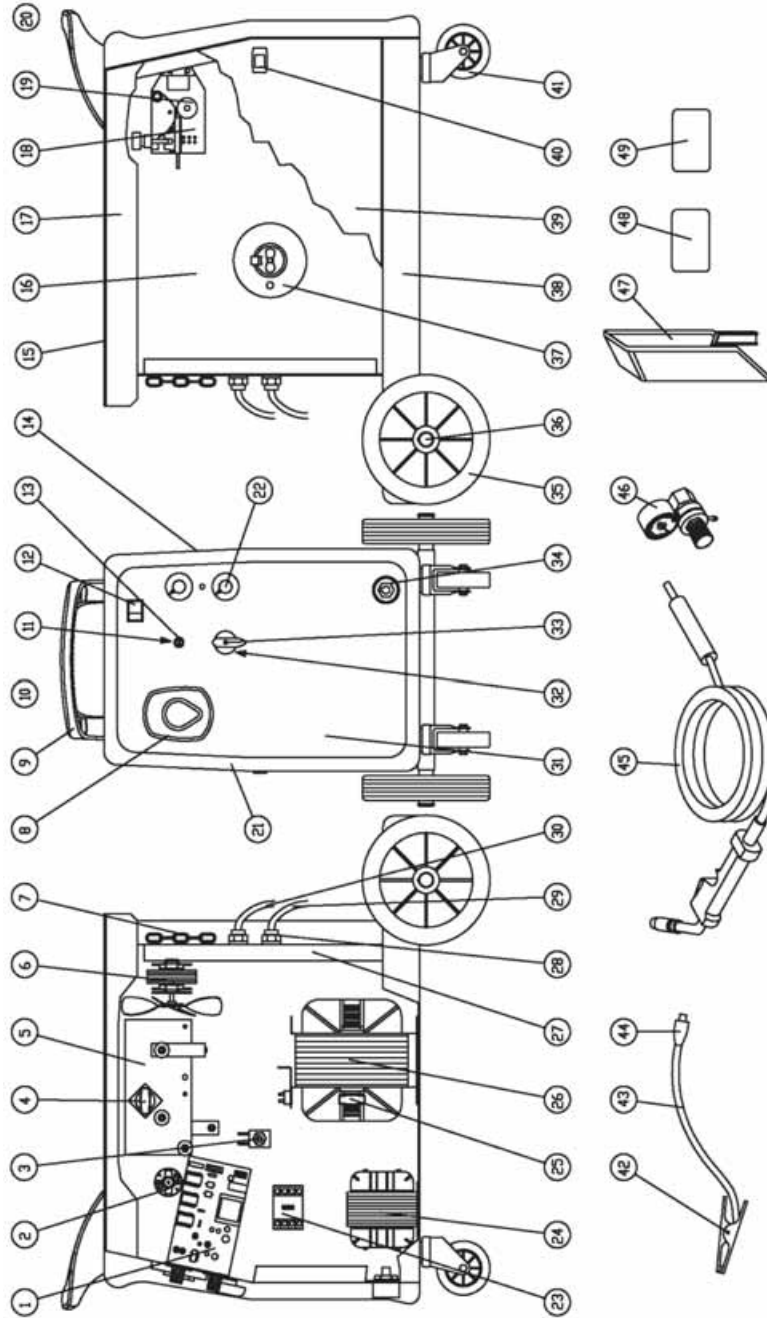

PARTS LIST - MIG 205TE

Item	Description	Qty	Part No:
1	PC Board HE11 220V	1	EM22710048
2	Wire Feeding Meter 24V	1	EM04600156
3	Gas Solenoid Valve 4W 220V 50Hz	1	EM22900001
4	Complete Thermostat 6A	1	EM04600113
5	Rectifier PMS 16/4/2 F	1	EM22400009
6	Fan 230V	1	EM22800002
7	Chain	1	EM04600205
8	Tarch Grommet	1	EM21690268
9	Handle	1	EM21600042
11	Fuse 250V	1	EM22220002
12	On/Off Switch 16A-250V	1	EM22200002
13	Fuse Holder 6,3A 250V	1	EM22220016
14	Right Panel	1	EM33705292
15	Tool Mat	1	EM30905021
16	Dividing Panel	1	EM33720088
17	Upper Panel	1	EM33705449
18	Plastic Wire Feeder D.48	1	EM44400003
19	Wire Feed Roll 0,6-0,8mm	1	EM33805023
19	Wire Feed Roll 0,8-1 Nylon	1	EM33805027
20	HandleBase (pair)	1	EM21690235
21	Plastic Front Frame	1	EM21690234
22	Potentiometer Knob	2	EM21690309
23	Contacto 220V 10A	1	EM22225006
24	Choke 40x50	1	EM44135017
25	Thermostat 16A	1	EM22210016
26	Transformer 230V 45x90	1	EM441 20093
27	Rear Panel	1	EM33715091
28	Cable Clamp D.20	2	EM21605010
29	Input Cable 3x2,5 M2,5	1	EM20220020
30	Black Hose D.5x10,5 L=2500	1	EM30900027
31	Front Panel	1	EM33710306
32	Switch 16A	1	EM22205016
33	Switch Knob D38	1	EM21690312
34	Dinsel Plug 25mm2	1	EM22100002
35	Wheel D. 175 Rubber. D.20 Hole	2	EM21625009
36	Wheels-Axle D20	1	EM55200030
37	Complete Spool Holder D50	1	EM04600001
38	Lower Panel	1	EM33700161
39	Side Panel	1	EM33705391
40	Side Panel Clip	1	EM21690177
41	Caster D.80	2	EM21625002
42	Earth Clamp	1	EM22110007
43	Earth Cable 16mm2	1	EM43210009
44	Dinsel Plug 25mm2	1	EM22100001
45	Torch Plus 14 M3 Direct Conn.	1	EM23000324
46	Reducer Mini Arg/UK W/Gauge	1	EM22905004
47	Mask 82x108	1	EM21905019
48	Transparent Glass 82x108	1	EM21905020
49	Dark Glass 82x108	1	EM21905021

PARTS DRAWING - MIG 230TEC

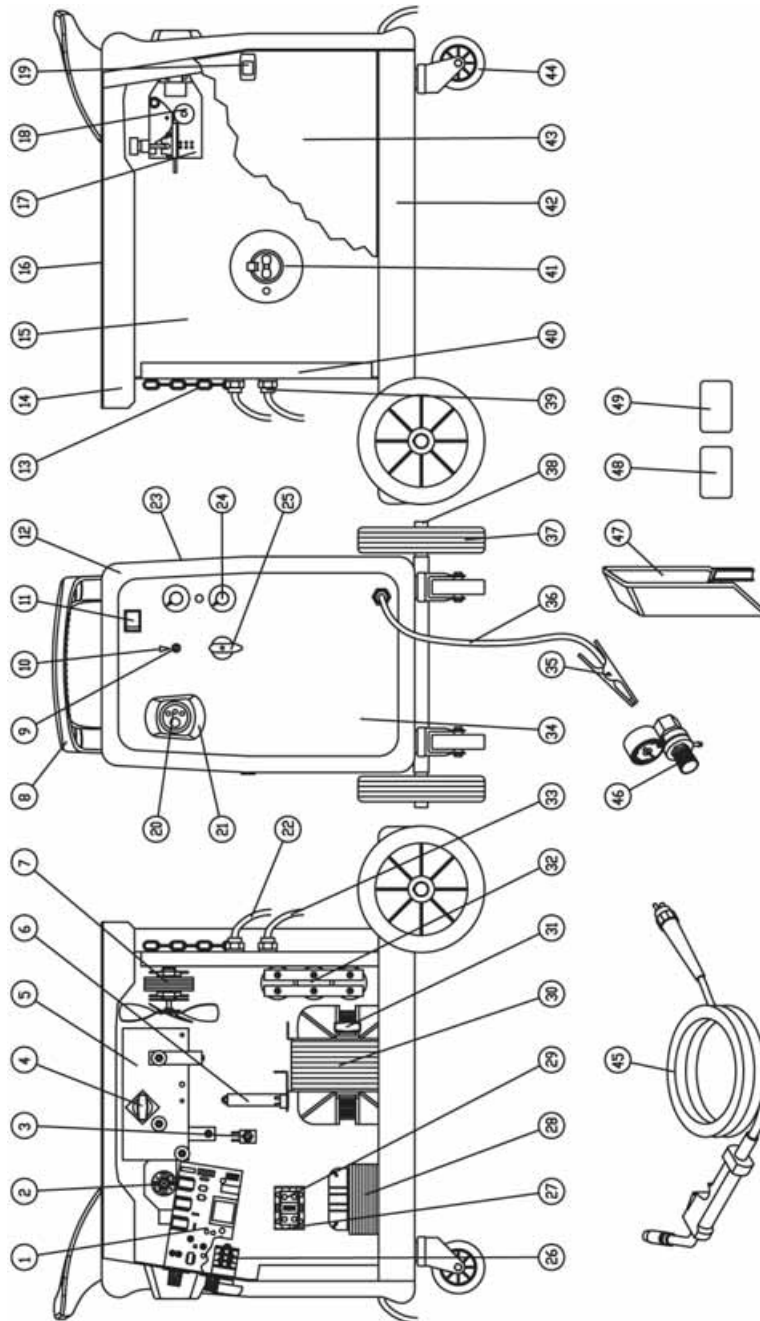

PARTS LIST - MIG 230TEC

No.	Description	Qty	Part No:
01	Motor Contr. Rob. Hell .01 220V 100x120	1	EM22710048
02	Motor MP48 24V	1	EM04600156
02	Motor Brush For Motor D.48	2	EM22810064
03	Gas Solenoid Valve 4W 220V 50Hz	1	EM22900001
04	Complete Thermosta + Support	1	EM04600113
05	Rectier Pins 16/4/2 F	1	EM22400009
06	Resistance 3 Ohm D.16 L=90	1	EM22305004
07	Fan 020 220V	1	EM22800002
08	Handle	1	EM21600042
09	Fuse Holder P11/35 6,3A 250V	1	EM22220016
10	Fuse 5x20 T1A250V	1	EM22220002
11	On/off Switch 16A-250V	1	EM22200002
12	Plastic Front Frame	1	EM21690234
13	Zinc Chain Nr 17 Nm 3,1	1	EM04600205
14	Cover Panel	1	EM33705449
15	Dividing Panel	1	EM33720088
16	Holder Mat 3x180x536	1	EM30905021
17	Plastic Wire Feeder D.48 Rolls 06-08	1	EM44400003
18	Wire Feed Roll D.9x30 0,6-0,8mm Knurled	1	EM33805023
19	Slide Clip	1	EM21690226
20	Mini Euro Torch Connection	1	EM23005180
21	Torch Connection Cover	1	EM21690267
22	Black Hose D.5x10,5 L=2500	1	EM30900027
23	Right Panel	1	EM33705292
24	Potentiometer Knob	2	EM21690309
25	Swicth Knob D.38	1	EM21690312
26	Switch 16A Cm 16	1	EM22205016
27	Contacto 220V 10A	1	EM22225006
28	Choke D.6	1	EM44135126
29	Auxiliary Contacts	1	EM22225018
30	Transformer 1 ph 230V 45x90 Al	1	EM44120053
31	Thermostat 16A	1	EM22210016
32	Capacitor 12000 Mf 63V 50x80	3	EM22315002
33	PVC Input Cable 3x2,5 M.2,5	1	EM20220020
34	Front Panel	1	EM33710306
35	Earth Clamp 150-200A	1	EM22110007
36	Earth Cable 162mm M2 WC261	1	EM43210010
37	Wheel D. 180 Rubber	2	EM21625040
38	Wheels Axle D.20 L=462	1	EM55200030
39	Cable Clamp For Hole D.20	3	EM21605010
40	Rear Panel	1	EM33715091
41	Complete Spool Holder D.50	1	EM04600001
42	Lower Panel	1	EM33700161
42	Side Panel	1	EM33705391
44	Rubber Pivoting Wheel D.85	2	EM21625002
45	Torch Plus 14 M 3 Bz Conn L,B14	1	EM23000322
46	Reducer Mini 1/gauge	1	EM22905004
47	Carton Mask 82x108	1	EM21905019
48	Transparent Glass 82x1 08	1	EM21905020
49	Dark Glass 82x108	1	EM21905021

WIRING DIAGRAM - MIG 195TEC & MIG 230TEC

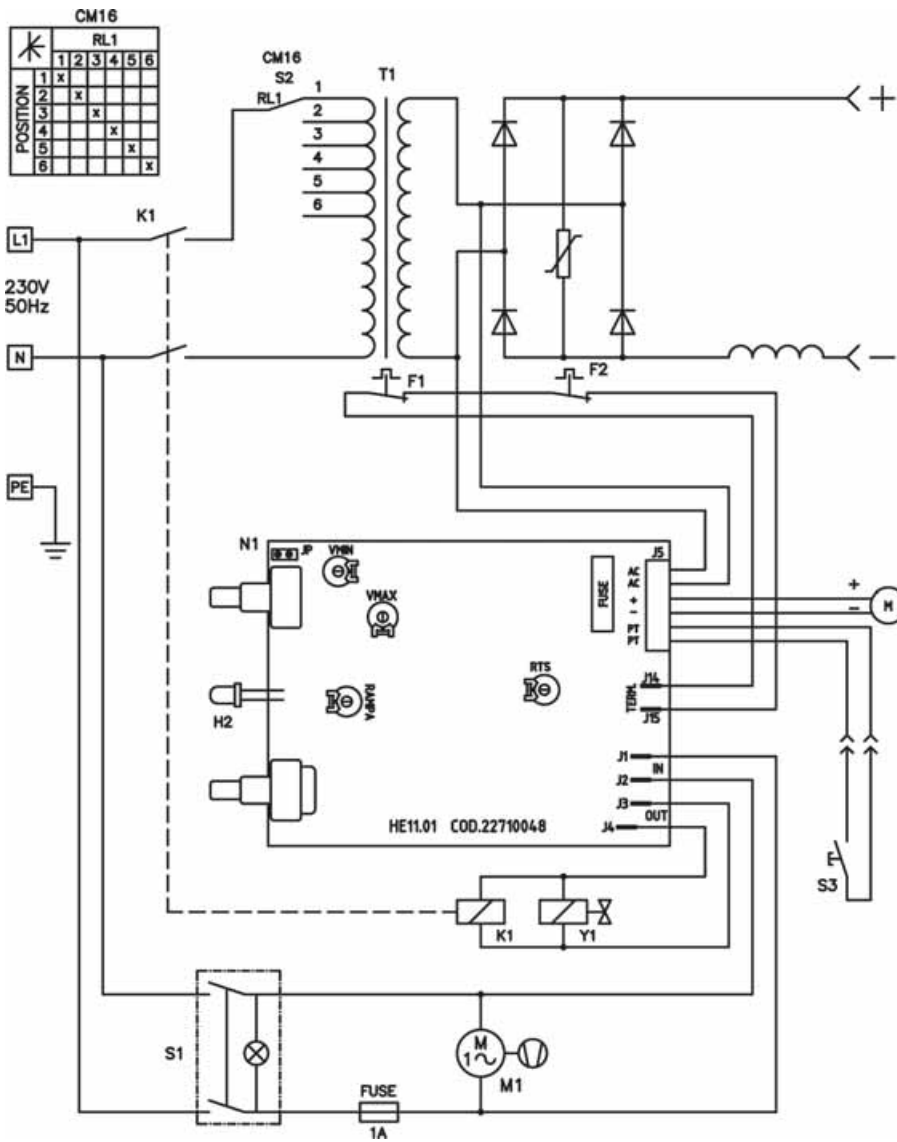

WIRING DIAGRAM - MIG 205TE

