

Clarke®



SUBMERSIBLE PUMP GSE RANGE

OPERATION & MAINTENANCE
INSTRUCTIONS



0507



Please read these instructions carefully before operating the tool

Thank you for purchasing this **CLARKE** Submersible Pump. These pumps are ideal for draining ponds, pools and building excavations, these heavy duty pumps can handle small solids in suspension. Before using the device, please read this manual thoroughly and carefully follow all instructions given. This is for your own safety and that of others around you, and is also to help you achieve long and trouble free service from your new tool.

CLARKE GUARANTEE

This CLARKE product is guaranteed against faulty manufacture for a period of 12 months from the date of purchase. Please keep your receipt as proof of purchase.

This guarantee is invalid if the product is found to have been abused or tampered with in any way, or not used for the purpose for which it was intended.

Faulty goods should be returned to their place of purchase, no product can be returned to us without prior permission.

This guarantee does not affect your statutory rights.

PARTS & SERVICE TEL: 020 8988 7400

or e-mail as follows:

PARTS: Parts@clarkeinternational.com

SERVICE: Service@clarkeinternational.com

Please note that the details and specifications contained herein are correct at the time of going to print. However CLARKE International reserve the right to change specifications at any time without prior notice. Always consult the machines data plate

Features

- Continuously rated, fitted with overload protection.
- Corrosion resistant stainless steel casing.
- Cast iron impeller and base for long and reliable service.

Contents

Guarantee	2
Specifications	3
Safety Precautions	4
Electrical Connections	5
Operation	6
Maintenance/Troubleshooting	7
Parts GSE1 & GSE1A	9 & 10
Parts GSE 150 & GSE150A	11 & 12
Parts GSE2 & GSE2A	13 & 14

Specifications

Model	Voltage	Outlet Inches	Outlet L/Min	Max Head M	Motor HP	Weight KG	Part No
GSE1	230vac	1"	180	9.5	0.5	20	7230070
GSE1A	230vac	1"	180	9.5	0.5	20	7230071
GSE150	230vac	1½"	280	17	0.8	24	7230072
GSE150A	230vac	1½"	280	17	0.8	24	7230073
GSE2	230vac	2"	500	10	0.8	30.5	7230074
GSE2A	230vac	2"	500	10	0.8	30.5	7230075
GSE2	110vac	2"	500	10	0.8	30.5	7230076
GSE2A	110vac	2"	500	10	0.8	30.5	7230077

NOTE 'A' = Models with automatic float switch.

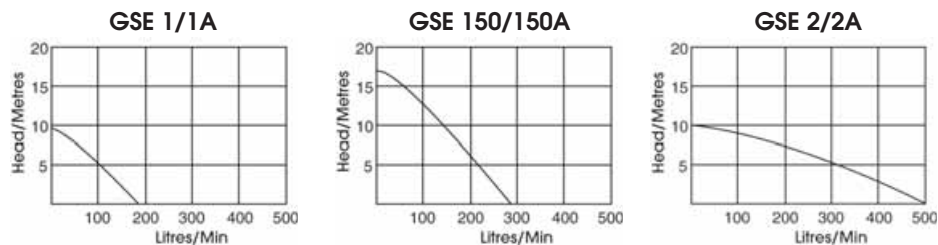

Safety Precautions



WARNING:



As with all machinery, there are certain hazards involved with their operation and use. Exercising respect and caution will considerably lessen the risk of personal injury. However, if normal safety precautions are overlooked or ignored, personal injury to the operator even damage to the pump or property, may result. For your own safety and that of others around you, please read these safety instructions in conjunction with the operating instructions, and before using the pump.

- These pumps are designed to pump **Water Only**. **NEVER** use for pumping flammable liquids or chemicals of any kind.
- An approved Residual Current Device (RCD) **MUST** be used when pumping from ponds or swimming pools.
- Your submersible pump may **ONLY** be used for pumping water from a swimming pool when there is no person or animal in the pool.
- If the water is likely to freeze, the pump **MUST** be run continuously, otherwise the pump must be removed from the water and stored in a frost free location.
- If the pump is to be used where there may be silt or mud etc (e.g., garden ponds), keep the pump clear of any sediment by standing it on a platform or brick or suspending from a rope attached to the handle.
- **NEVER** run the pump dry.
- **NEVER** run the pump with the body exposed for longer than 10 minutes.
- **NEVER** install the pump on sand, silt, mud or ground that is likely to shift.
- **NEVER** Lift the pump by the mains cable, or the float switch cable.
- **ALWAYS** use the handle, with rope or chain attached when lifting the pump.
- **ALWAYS** disconnect the pump from the electrical supply before placing it into, or removing from the water, and before any cleaning or maintenance of the pump.



Electrical Connections

230 Volt models:

Connect the mains lead to a standard 230 Volt (50Hz) electrical supply through an approved BS1363, 13amp plug or a suitably fused isolator switch.

110 Volt models:

Connect the mains lead to a suitable 110 Volt (50Hz) electrical supply through an approved plug or a suitably fused isolator switch. If using a portable 110 Volt transformer make sure it has a rated capacity sufficient to take the load of the pump.

All models:

We recommend that this pump is connected to the mains supply through a Residual Current Device (RCD).



WARNING! THIS APPLIANCE MUST BE EARTHED

IMPORTANT: The wires in the mains lead are coloured in accordance with the following code:

Green & Yellow	-	Earth
Blue	-	Neutral
Brown	-	Live

As the colours of the flexible cord of this appliance may not correspond with the coloured markings identifying terminals in your plug proceed as follows:

- Connect GREEN & YELLOW cord to terminal marked with a letter "E" or Earth symbol  or coloured GREEN or GREEN & YELLOW.
- Connect BROWN cord to terminal marked with a letter 'L' or coloured RED
- Connect BLUE cord to terminal marked with a letter 'N' or coloured BLACK

230 Volt models:

If this appliance is fitted with a plug which is moulded onto the electric cable (i.e. non-rewirable) please note:

1. The plug must be thrown away if cut from the electric cable. There is a danger of electric shock if it is subsequently inserted into a socket.
2. Never use the plug without the fuse cover fitted.
3. Should you wish to replace a detachable fuse carrier, ensure that the correct replacement is used (as indicated by marking or colour code).
4. Replacement fuse covers can be obtained from your local dealer or most electrical stockists.
5. The fuse in the plug must be replaced with one of the same rating (13amps) and this replacement must be ASTA approved to BS1362.

IMPORTANT:

*If you are in any doubt regarding electrical installation,
you should consult a qualified electrician*

Operation

Connect a length of delivery hose (not supplied) to the outlet spigot of the pump (GSE and GSE1A pumps require 1" hose, GSE2 and GSE2A require 2" hose). Suitable hose is available from your nearest CLARKE dealer.

CLARKE submersible pumps are designed for use with fresh water. Avoid using your pump with salt water, or with water containing chemicals, as these can cause damage to the pump. If the pump does come into contact with salt or water containing chemicals, wash it immediately. GSE pumps will handle small solids in suspension, making it suitable for draining sumps, pits and excavations etc.

Inspect the pump regularly to check that the base inlet is clear of leaves or other debris. Any blockage of mud or leaves can be cleared by washing the pump in fresh water, or by using a hose to flush fresh water back through the pump outlet connector. Never switch on the pump with the outlet connected to the mains water supply.

GSE 1A, 150A and 2A pumps incorporate an automatic float switch. As the water level rises, the switch will float, and start the pump. As the water level falls, so will the float switch, which in turn will switch the pump off. The position of the float switch can be adjusted by repositioning the cable in its clip.

For the float switch to operate correctly it must be able to move freely. When putting the pump into position, ensure there is nothing which might impede the float switch movement.

GSE pumps are fitted with automatic overload protection. If the motor overheats (because of an obstruction in the pump, or pumping warm water, for example), it will shut off automatically. Switch the pump off and isolate from the main electric supply, check for blockages, and remove, allow the motor to cool down before attempting to restart. The thermal overload will normally reset in a few minutes.

This pump should require little or no maintenance other than regular cleaning. If the pump starts to show signs of wear or damage, contact your nearest CLARKE dealer for advice. Do Not use the pump if there is any damage to the mains supply or float switch cable.

Do Not attempt to repair the pump yourself, (other than to replace listed parts on pages 10 & 12), as you may invalidate your guarantee, and damage the waterproof seal of the pump.

If using this pump in a garden pond, please note that there is a small quantity of oil in the pump seal. If the pump seal is worn or damaged, oil may leak out, and appear as a film on the surface of the water. Although harmless to people, the oil must be cleared to prevent any possible harm to pond life. Disconnect the pump from the electrical supply, remove it from the pond, clear the oil and contact the CLARKE service department for advice, on 020 8988 7400.

Once satisfied the pump is installed, and taking all the necessary safety and electrical precautions as described on pages 4 & 5, plug into the mains supply and switch ON.

NOTE:

If the pump does not deliver immediately, it is possible that an air lock exists, Leave the pump for approximately one minute in order for the air lock to be displaced. If necessary switch OFF and On again, the pump should now deliver water, if not check all hose connections etc.

**SUITABLE HOSE, and SPARE/REPLACEMENT HOSE ADAPTERS ARE
AVAILABLE FROM YOUR NEAREST CLARKE DEALER**

Maintenance

WARNING

Before carrying out any maintenance activities to your submersible pump, ensure it is isolated from the mains supply, by switching OFF and removing the plug from the socket.

Your submersible pump should require no maintenance other than regular inspection and cleaning.

Check the pump installation regularly to ensure the base inlet is clear of leaves or other foreign objects, mud silt etc.

if the pump starts to show signs of wear or damage, contact your nearest Clarke dealer for advice.

DO NOT ATTEMPT TO CARRY OUT REPAIRS TO THE PUMP YOURSELF UNLESS YOU ARE FULLY COMPETENT. REMEMBER WATER AND ELECTRICITY DO NOT MIX.

If in any doubt, contact your nearest CLARKE dealer for advice.

Trouble Shooting

A. Pump Will Not Start

1. Float switch may be jammed against side wall, or prevented from moving.
2. Water level too low - float switch in OFF position - lift float to check switch.

B. Pump Will Start But Not Deliver

1. Check to ensure base is not blocked by leaves etc.
2. Discharge tube blocked or obstructed etc.
3. The head may be too great, i.e., you are trying to lift water too great a distance for the pump to cope with. (See specifications on page 3).
4. Impeller may be damaged - contact your nearest CLARKE dealer.
5. Air lock in system. Switch OFF and ON again to deaerate the system.

C. Pump Will Not Stop

1. Float switch may be prevented from moving to fully down position.
2. Float switch may be faulty - contact your nearest CLARKE dealer.

D. Pump Stops Running

1. Thermal overload has operated, switch OFF, allow to cool down, switch on again. Check for possible causes for motor to overheat.
2. Float switch has operated. Check operation of switch.
3. No Electrical; supply.... investigate cause, i.e., check fuse/RCD etc.

Parts Diagram (GSE 1 & GSE 1A)

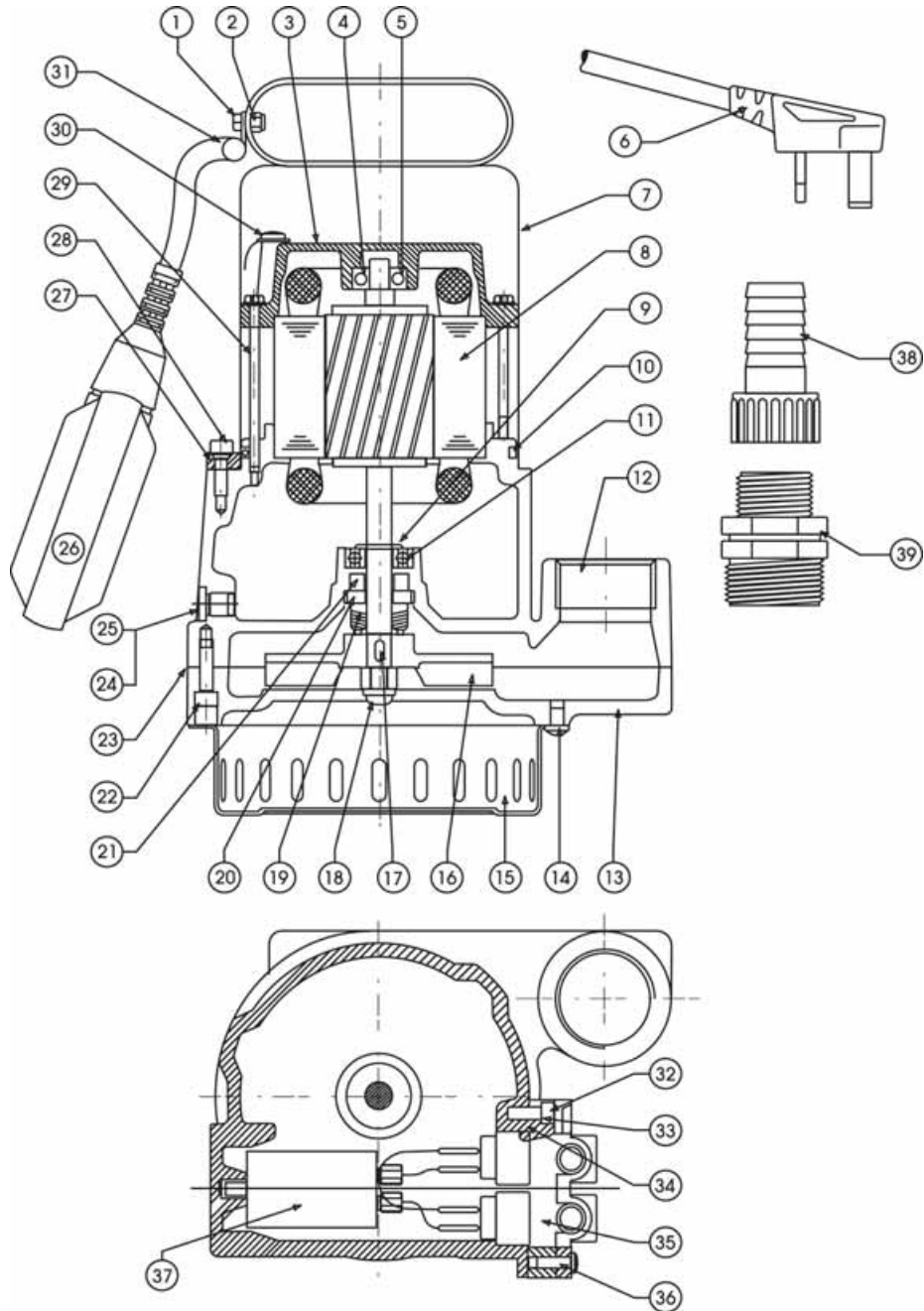

Parts List (GSE 1 & GSE 1A)

INDEX	PART NUMBER	DESCRIPTION	QTY
1	GM7099	Inox Screw	1
2	GM7144	Inox Nut	1
3	GM7206	Flange	1
4	GM8138	Elastic Washer	1
5	GM7212	Bearing	1
6	GM8357	10M Cable Comp With Plug	1
7	GM7205	Inox Housing	1
8	GM5662	Motor Complete	1
9	GM6029	Seeger	1
10	GM7215	'O' Ring 4437	1
11	GM8344	Bearing	1
12	GM7202	Pump Body	1
13	GM7862	Base	1
14	N/A	Inox Screw	4
15	GM8183	Inox Filter	1
16	GM7870	Impeller	1
17	GM7210	Inox Key	1
18	GM7103	Brass Inox	1
19	GM7152	Mechanical Seal	1
20	GM7147	Counterface	1
21	GM6062	Gasket	1
22	GM7697	Screw	4
23	GM7208	Flexolite Gasket	1
24	GM7117	Tap 1/8"	2
25	GM6048	'O' Ring 6048	2
26	GM7231	Float Switch	1
27	GM7096	Aluminium Washer	3
28	GM6251	Inox Screw	3
29	GM6560	Screw	2
30	GM7216	Screw	1
31	GM7123	Stop Cable	1
32	GM7221	Inox Screw	3
33	GM7218	Inox Washer	3
34	GM7214	'O' Ring 3187	1
35	GM7226	Connector	1
36	GM7217	Inox Screw	3
37	GM7209	Condenser 6,3 MY	1
38	GM1073	Connection 1" x 25	1
39	GM7707	Nipple 1" to 1-1/4"	1

PARTS & SERVICE TEL: 020 8988 7400

or e-mail as follows:

PARTS: Parts@clarkeinternational.com

SERVICE: Service@clarkeinternational.com

Parts Diagram (GSE 150 & 150A)

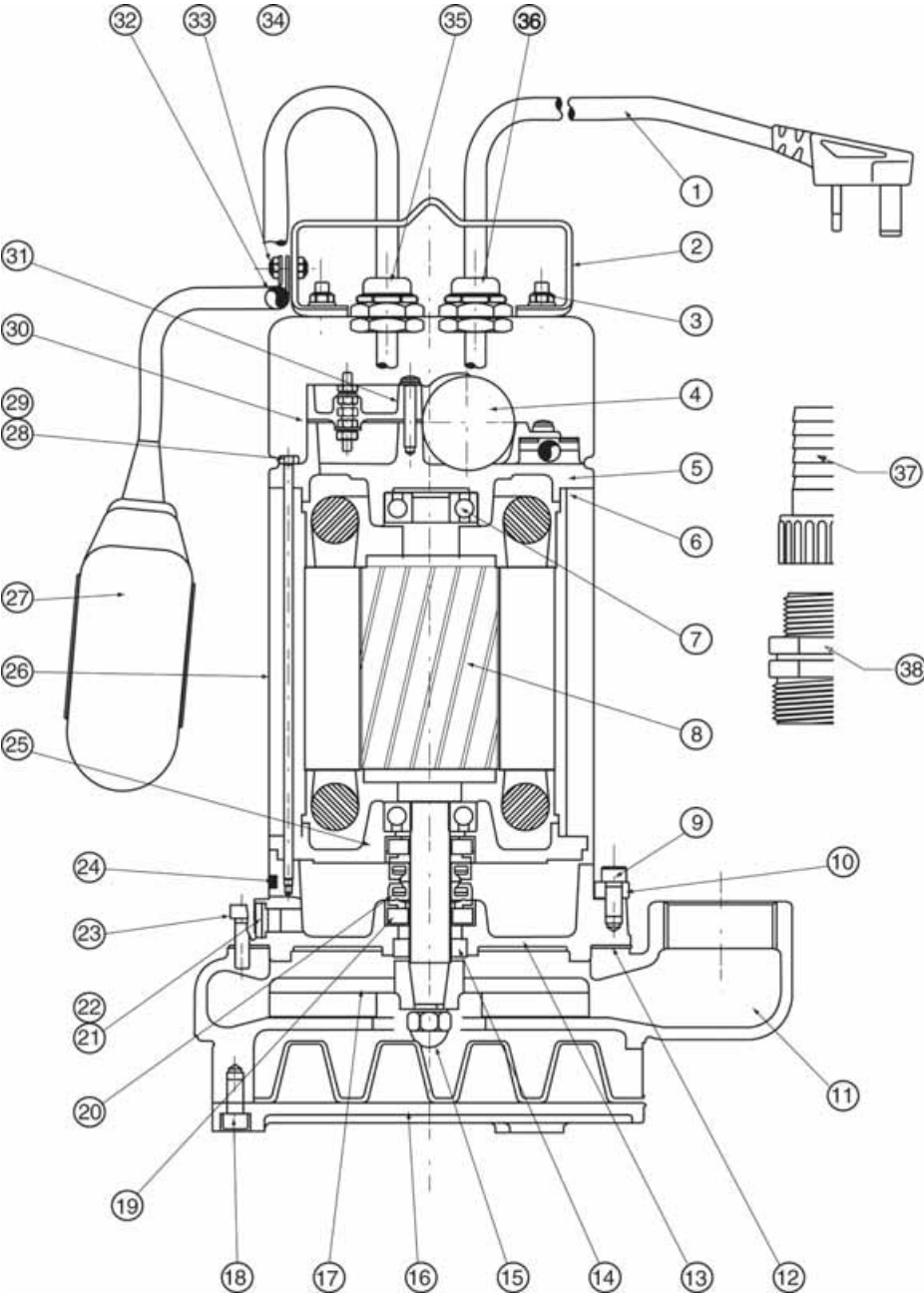

Parts List (GSE 150 & 150A)

INDEX	PART NUMBER	DESCRIPTION	QTY
1	GM8355	10M Cable With Plug	1
2	GM8221	Inox Handle	1
3	GM8185	Inox Nut	2
4	GM8235	Condenser 16 MY	1
5	GM7093	Superior Flange	1
6	GM7105	'O' Ring 107.7 x 1.78	2
7	GM7111	Bearing 6203	2
8	GM8113	Motor	1
9	GM8269	Inox Screw	4
10	GM7097	Inox Washer	4
11	GM5507	Pump Body	1
12	GM7109	Flexolife Gasket	1
13	GM7084	Bracket	1
14	GM6062	Gasket	1
15	GM7103	Brass Nut	1
16	GM7247	Base	1
17	GM7086	Impeller	1
18	GM5442	Inox Screw	3
19	GM7147	Counterface	2
20	GM7153	Mechanical Seal	2
21	GM7117	Tap 1/8"	2
22	GM6048	'O' Ring 2037-110	2
23	GM7098	Inox Screw	4
24	GM7106	'O' Ring 4512	2
25	GM7092	Inferior Flange	1
26	GM7156	Inox Housing For GSE 150	1
26A	GM7157	Inox Housing For GSE 150A	1
27	GM7137	Float Switch (GSE 150A)	1
28	GM7107	'O' Ring 2.9 x 1.78	4
29	GM7113	Screw	4
30	GM6429	Gasket	1
31	GM6705	Flange For Cable Connection	1
32	GM7123	Stop Cable	1
33	GM7099	Inox Screw	1
34	GM7144	Inox Nut	1
35	GM7875	Cable-Lock	1
36	GM7876	Cable-Lock For Float Switch	1
37	GM1035	Connection 1" x 40	1
38	GM1095	Nipple From 1/2" to 1-1/2"	1

Clarke
INTERNATIONAL

Parts Diagram (GSE 2 & 2A)

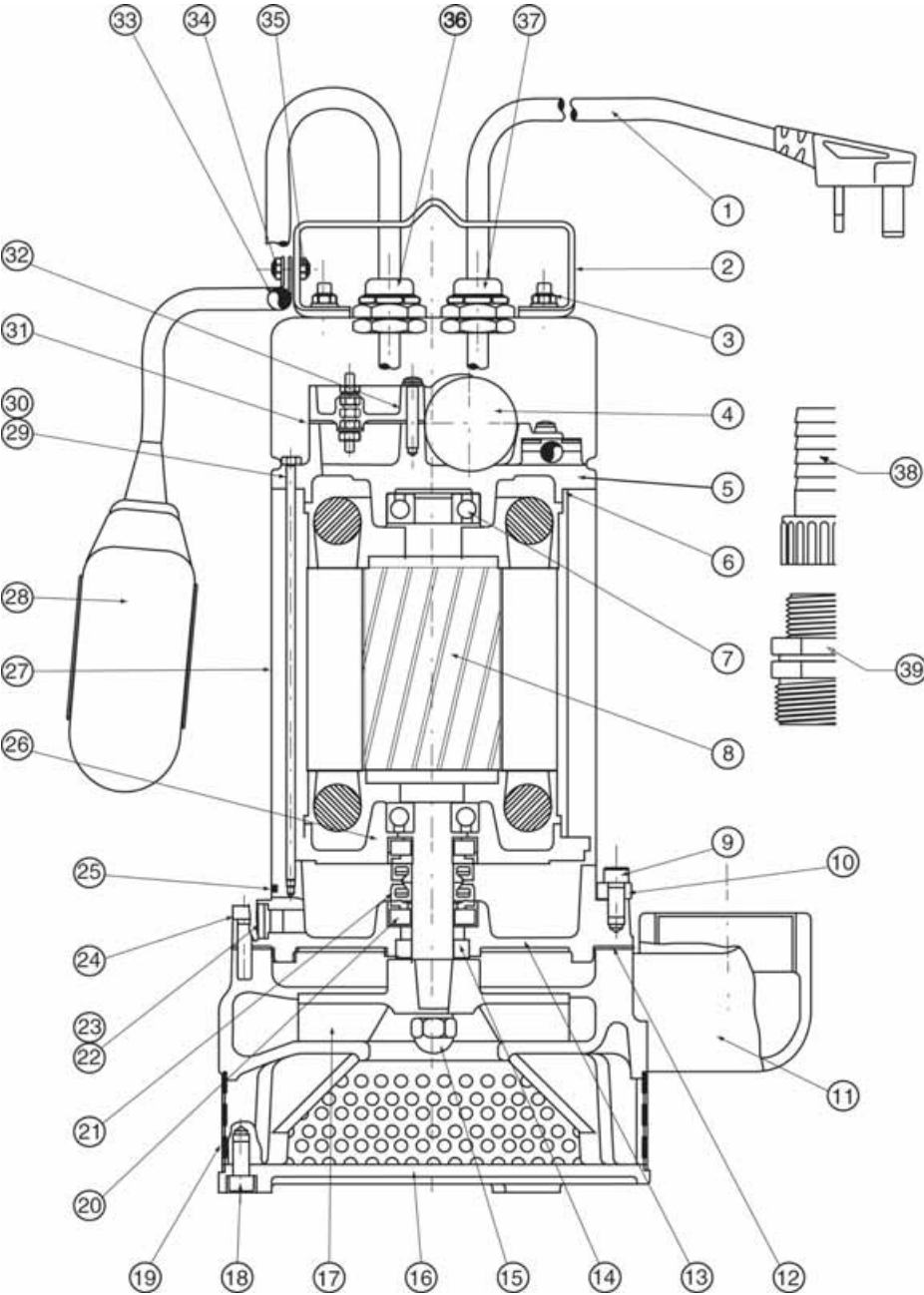

Parts List (GSE 2 & 2A)

INDEX	PART NUMBER	DESCRIPTION	QTY
1	GM8357	10M Cable With Plug for GSE 230V	1
1A	GM8356	10M Cable Without Plug for GSE 110V	1
2	GM8211	Inox Handle	1
3	GM8185	Inox Nut	2
4	GM8235	Condenser 16MY For GSE 230V	1
4A	GM8236	Condenser 20MY For GSE 110V	2
5	GM7093	Superior Flange	1
6	GM7105	`O' Ring 107.7 x 1.78	2
7	GM7111	Bearing 6203	2
8	GM8113	Motor For GSE 230V	1
8A	GM8100	Motor For GSE 110V	1
9	GM8269	Inox Screw	4
10	GM7097	Inox Washer	4
11	GM7082	Pump Body	1
12	GM7109	Flexolite Gasket	1
13	GM7084	Bracket	1
14	GM6062	Gasket	1
15	GM7103	Brass Nut	1
16	GM7005	Base	1
17	GM6623	Impeller	1
18	GM5442	Inox Screw	3
19	GM6774	Filter	1
20	GM7147	Counterface	2
21	GM7153	Mechanical Seal	2
22	GM7117	Tap 1/8"	2
23	GM6048	`O' Ring 2037-110	2
24	GM7098	Inox Screw	4
25	GM7106	`O' Ring 4512	2
26	GM7092	Inferior Flange	1
27	GM9879	Inox Housing For GSE 2	1
27A	GM9878	Inox Housing For GSE 2A	1
28	GM7137	Float Switch (GSE 2)	1
29	GM7107	`O' Ring 2.9 x 1.78	4
30	GM7113	Screw	4
31	GM6429	Gasket	1
32	GM6705	Flange For Connection Cable	1
33	GM7123	Stop Cable	1
34	GM7099	Inox Screw	1
35	GM7144	Inox Nut	1
36	GM7875	Cable-Lock	1
37	GM7876	Cable-Lock For Float (GSE 2A)	1
37	GM1017	Connection 2" x 50	1
38	GM1095	Nipple From 2" to 2"	1

IMPORTANT:

The use of parts other than CLARKE replacement parts may result in safety hazards, decreased tool performance and may invalidate your warranty.