

# CUT-OFF SAW

**(Fox model F20-140A)**



# Cut-off saw (FOX model F20-140A)

## INDEX

- Safety instructions
- General safety instructions
- Specific safety instructions for cut-off saw
- Environment protection
- Symbols
- Electrical connections
- Recommended use
- Technical specifications
- Noise conditions
- Cut off photos
- Removal of package
- Machine description
- Lock pin of the head
- Controls and adjustments
  - A. On/Off switch
  - B. Vice
  - C. Angle cut
  - D. Adjustment of the lowering of the disc
  - E. Transport handle
- Functioning
- Replacement of the disc
- Maintenance
  - A. Check and replacement of the carbon brushes
- Malfunctions
- Serracon Guarantee

## **SAFETY INSTRUCTIONS**

### **CAUTION:**

Besides following the instructions mentioned in this manual, when using electric equipment you must always observe all safety precautions to prevent risk of fire, electric shock and personal injury.

**Read this instruction manual before use and keep it carefully.**

Working with an electric machine can be dangerous if you do not follow suitable safety measures. As for any electric machine with moving parts, the use of a tool entails some risks. If you use the machine as prescribed in this manual, you pay careful attention to the work you are doing, you observe the regulations and you use the suitable personal devices of protection, you can reduce the probability of risk. The possible remaining risks are related to:

- 1 – direct or in direct contacts with electrical shock
- 2 – injuries due to contact with moving parts
- 3 – injuries due to contact with angular parts
- 4 – injuries due to the ejection of tool parts or of the material you are processing
- 5 – injuries due to noise

The probability of risk can be reduced by the machine safety equipment of the machines, as for example the protections, the blade case, the clamping, the stoppage and the personal protection devices as protective goggles, the dust mask, ear plugs, protective shoes and gloves. However, even the best protection devices cannot protect you from the risks due to lack of good sense and attention. Have always good sense and observe the necessary precautions. Carry out only the works that you consider safe. **DO NOT FORGET:** everyone is responsible for his safety.

This tool has been designed for specific purposes. FEMI recommend you not to modify it or use it for purposes different from the ones for which it has been manufactured. If you have any doubts regarding specific applications, do not use the machine before having contacted FEMI and received our instructions.

***READ AND KEEP THIS MANUAL***

## GENERAL SAFETY INSTRUCTIONS

1. **Keep the work surface clean.** If the work area or surface is busy the probability of injuries is higher.
2. **Do not use** the machine in dangerous environment conditions. In order to prevent electric shock, **do not expose the machine** to rain and do not use it in a damp area. Keep the work area illuminated. **Do not use the machine** near gas or inflammable substances.
3. **Connect** the dust collection device. If the machine is provided with a dust collection device, make sure that this system is connected and correctly used.
4. **Keep** unknown persons and children away from the machine. All unknown persons and children must keep a safe distance from the work area.
5. **Protect yourself** from electric shock. Avoid any contact with earthing surfaces.
6. **Handle** the power supply cable with care. **Do not pull** the electric cable to disconnect it from the plug. Keep the electric cable away from heat, oil and sharp edges.
7. **Use** extension cables designed for outdoor use. When using the machine outdoors, use only extension cables suitable for outdoor use, having specific indications.
8. **Be vigilant.** Check carefully what you are doing, have good sense. Do not use the machine if you are tired.
9. **Do not use** the machine if you are have taken medicines, alcohol, drugs.
10. **Avoid** accidental starts. Be sure that the switch is on the OFF position before inserting the plug into the socket.
11. **Wear appropriate clothing.** Do not wear loose-sleeved garments or pieces of jewellery which may get caught in the moving parts. For outdoor use we recommend non-slip shoes. Use headgear to cover hair if necessary.
12. **Use always personal protection devices:** wear protective goggles and masks in case dust or sawdust is produced. Wear ear muffs or plugs in noisy areas. Wear gloves when handling parts with sharp edges.
13. **Do not be off balance** over the machine. Always keep stand firmly.
14. **Ask** for advices to expert and qualified people if you are not familiar with using such a machine.
15. **Remove** the tools you do not use from the workbench. If you do not use the tools, you must arrange them in a dry area which is locked and away from the reach of children.
16. **Do not force** the machine. You can obtain better and safer results if you use the machine at the cutting pressure for which it has been designed.
17. **Use** the suitable tool. **Do not use** a small tool for an intensive job. Fox example, do not use a circular saw to cut branches or stumps.

18. **Block** the piece. If possible, use C-clamps or a holder to fix the piece. It is safer than using only your hands.
19. **Keep** the tools in perfect conditions. Keep the tools sharp and clean to obtain better and safer results. Follow the instructions to grease and change the accessories. Check regularly the electric cable and change it if it is damaged. Keep the handles and the handgrips dry, clean, unoiled and ungreased.
20. **Disconnect** the tool from electricity if you do not use it, before maintenance and change of the accessories or tools such as blades, drills, mills, etc.
21. **Remove** locking and adjustment wrenches from the workbench. Get used to check if the locking and adjustment wrenches have been removed before starting it.
22. **Check** the parts of the tool to verify that there are not any damages. Before using the machine, check if the safety devices or any other parts are damaged in order to be sure that it works properly and that it can accomplish the tasks for which it has been designed. Check that the moving parts are aligned, do not stop and are not broken. Check the assembly and any other condition that can influence the functioning of the machine. Any part or protection damaged must be repaired or changed from an authorised after sales centre. Do not use the machine if the switch does not work properly.
23. **Use** the machine, the tools and accessories in the way and for the purposes mentioned in this manual. Different uses and parts can cause possible risks for the operator.
24. **Get the machine repaired** by a qualified person. This electric tool is in compliance with local safety regulations. The machine must be repaired only by qualified people who use original spareparts, otherwise risks may arise for the operator.

## SPECIFIC SAFETY INSTRUCTIONS FOR CUT-OFF SAWS

1. **ALWAYS** disconnect the cut-off saw from the socket before any repair, maintenance work, cleaning, replacement of the saw blade or any kind of intervention.
2. **DO NOT START** the cut-off saw until it is completely assembled and installed according to the instructions of this manual, the protection devices are assembled and working, and the various lock handles are firmly tightened. Be sure that the lock screw of the disc is firmly tightened.
3. **PLACE** the cut-off saw on a plane and horizontal surface to avoid dangerous oscillations or movements.
4. **KEEP** your hands away from the disc's track and area.
5. **CORRECTLY FIX** the workpieces. The workpiece must be straight and properly blocked to avoid any movement and to prevent the workpiece from jamming at the end of the cutting.
6. **NEVER CUT** freehand.
7. **BE SURE** that the disc is completely still before removing or fixing the workpiece or before changing its angle.
8. **ALWAYS CHECK** that the disc is not cracked or damaged before using this tool. Immediately change the disc if it is cracked or damaged.
9. **ONLY USE** reinforced and recommended abrasive discs.
10. **CHECK** that the speed of the disc you are assembling is bigger than the one of the machine, only use discs that can bear a speed of 3900 RPM.
11. **CORRECTLY CLEAN** the flanges and the supporting surfaces of the disc before assembly.
12. **PROPERLY TIGHTEN** the lock screw to prevent the disc from slipping, while being careful not to damage the disc by deforming the contact surfaces with the flanges.
13. **ONLY USE** disc flanges intended for this tool.
14. **MAKE** the cut-off saw work without cutting after changing the disc to check that it works correctly.
15. **ALWAYS MAKE** the tool work for about a minute before cutting. If the disc has a crack or a fault which is not visible, it can break within a minute.
16. **BE SURE** that the abrasive disc is not in contact with the workpiece before starting the tool.
17. **LET** the motor run at its normal speed before using it.
18. **ALWAYS USE** the protective cap and be sure that it is perfectly efficient.
19. **ALWAYS USE** ear protection devices, protective goggle, the dust mask and protective shoes.
20. **SLOWLY LOWER** the disc until it come into contact with the workpiece, then lower it more quickly during cutting. Always keep the disc in contact with the workpiece, in order to prevent it from becoming oval. If the disc is oval, besides causing mediocre cuts, can entail dangerous breakings.
21. **LEAN** on supports the ends of big and heavy workpieces, in order to prevent the workpiece from falling and the risk of injuries.
22. **USE** this tool only for ferrous materials. **DO NOT CUT** wood, aluminium or magnesium.
23. **PLACE** the tool while taking into account the throw of glowing sparks.
24. **REGULARLY CHECK** if the power supply cable is damaged, and if it is the case get it repaired by an authorised after-sales centre. Regularly check the extension leads and change them if they are damaged.
25. **IMMEDIATELY STOP** the saw and disconnect it from the power supply if you realize that any part is damaged or faulty. Get the faulty part changed by an after-sales centre. Only use spareparts and accessories recommended by us.

## ENVIRONMENT PROTECTION

### INFORMATION FOR USERS

In accordance with art. 13 of Legislative Decree 25th July 2005, no. 151 "Implementation of Directives 2002/95/EEC, 2002/96/EEC and 2003/108/EEC, relative to reducing the use of hazardous substances in electric and electronic appliances and the disposal of waste", please take note of the following:

- The crossed out wheeled bin symbol found on the appliance or the packaging indicates that the product must be disposed separately from ordinary household waste when it reaches the end of its working life.
- The user must consign the unwanted appliance to an authorised waste disposal centre for electric and electronic goods, or alternatively, hand it over to the relative dealer at the moment of purchasing a new appliance of the same type on a basis of a one to one ratio.
- Differentiated disposal to enable possible recycling or environmentally compatible elimination of the appliance, helps to limit undesirable effects on health and environment and promotes the reuse and/or recycling of the materials that compose the appliance.

### **WARNING!**

**In accordance with the relative legislation in force in the country of use, sanctions will be imposed on the user if the appliance is disposed of illegally.**

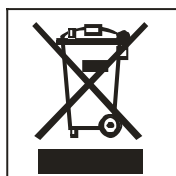

## SYMBOLS



Read the instruction manual carefully



Use personal protection devices (goggles, dust mask earphones)



It is forbidden to put your hands in this area. Danger of dragging/cutting.

F XXXXX08XXXXXX

Serial number / year of production

## ELECTRICAL CONNECTIONS

### ELECTRICAL CONNECTIONS

Use 230 V 50 Hz alternate voltage equipped with a earthing conductor to supply your machine. Ensure that the power supply corresponds to this voltage, that it is protected by a differential and magnetothermal switch, and that the earthing system is efficient. If your machine does not work when connected to a socket, check carefully the power supply features. Use an extension cable in order to connect the machine to the power supply.

### EARTHING INSTRUCTIONS

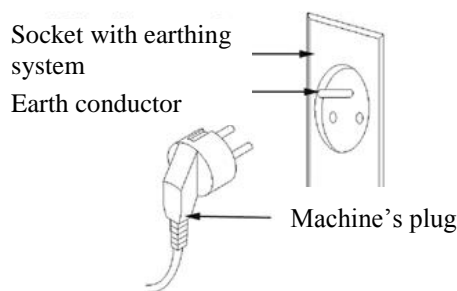

If the tool does not work properly or in case of short-circuit, the earthing system provides the current with a less resistance path and reduces the risk of electric shock. This tool has a plug to which a supply or extension cable must be connected, which in turn must be connected to a socket correctly installed and earthed, in conformity with local standards and regulations. Be sure that your earthing system is in good conditions and that your plug is protected by a differential and magnetothermal switch.

Do not modify the plug of the machine. If it does not enter the socket, get a suitable plug installed by a qualified person. If the earthing conductor is not correctly connected the risk of electric shock can occur. The conductor which has the green insulating jacket (with or without a yellow line) is the earthing conductor. If you must repair or change the supply cable, do not connect the earthing conductor to a low tension terminal.

Consult a qualified electrician or a person in charge of the maintenance if you have not understood or you have some doubts on the earthing instructions.

If the supply cable is damaged it must be changed by qualified people. Do not switch on the machine if the supply cable is damaged.

This tool is provided with a plug which must be connected to a suitable socket.

### EXTENSION LEADS

Only use three conductors extension leads, with a plug with two plugs and a earthing contact and sockets with two holes and a earth corresponding to the plug of the tool. When using an electric tool at a remarkable distance from the power supply, use an extension lead with sufficient dimensions to transport the current which the tool needs. If the extension lead has not the sufficient dimensions a voltage drop can occur, thus causing an overheating and a voltage loss. You can only use extension leads in compliance with CE standards.



**Extension lead length:** up to 15 m

**Cable dimensions:** 3 x 2,5 mm<sup>2</sup>

Before using any kind of extension lead, check there are not bare wires and that the insulation is not cut or worn. Repair and change immediately if it is damaged or worn.



**WARNING:**

Extension lead must be arranged away from the working area in order that they do not get in touch with the workpieces, the tool or other parts of the machine, thus creating possible risks.



**WARNING:**

**KEEP THE TOOLS AND THE EQUIPMENT AT A SAFE DISTANCE FROM CHILDREN**

### **RECOMMENDED USE**

This machine has been manufactured only for cutting metal ferrous materials.

You must use a suitable abrasive disc which has a maximum diameter of 355 mm.

You can cut a diameter of 127mm or a rectangle 127x152 mm.

The lock clamp of the workpiece can be rotated in order to cut from 0 to 45°.

This tool is not suitable for cutting other metal materials or non metal materials.

## TECHNICAL SPECIFICATIONS

Engine power:	2000 W
Voltage and frequency:	230 V – 50 Hz
Speed without cutting:	3000 RPM
Abrasive disc:	
External diameter:	355 mm
Bore diameter:	30 mm
<b>Capacity at 90° (with clamp)</b>	
Circle:	127 mm
Rectangle:	127 x 152 mm
Square:	127 x 127 mm
<b>Packing dimensions</b>	
Height:	430 mm
Width:	340 mm
Length:	600 mm
Vibrations hand arm (with load):	2.26 m/sec <sup>2</sup>
Weight:	18 kg

## NOISE CONDITIONS

The noise emitted, measured in conformity with the standards EN 3744 and EN 11201 is:

- Sound pressure level  $L_{pA} = 94,3$  dB(A)
- Sound power level  $L_{WA} = 107,3$  dB(A)
- Uncertainty of measurement  $K = 3$  dB

**We recommend you to use ear protection devices.**

The sources of the noise of the saw are: the electric engine and its ventilation system, the blade and the material to be cut.

We advise you to control the engine, its ventilation system and the aspiration passages. As far as the saw blade is concerned, it is preferable to use silenced type of blades and to keep them in good conditions. We recommend to use the correct saw blade and to keep firmly the workpiece to be cut. As far as the gears are concerned, you have only to check periodically their consumption by verifying the play with the saw blade.

Noise levels are emission levels and do not necessarily indicate safe working conditions. Even if there is a connection between emission levels and exposure levels, the first ones cannot be used to determine safely if other precautions are necessary. The factors that can influence the actual exposure level of the operator include the exposure length, environment features and other sources of noise, as for example the number of machines and operations present. Besides, exposure levels can change from country to country. However, these instructions enable the user of the machine to better evaluate the dangers and risks.

**CUT OFF SAW PHOTOS**

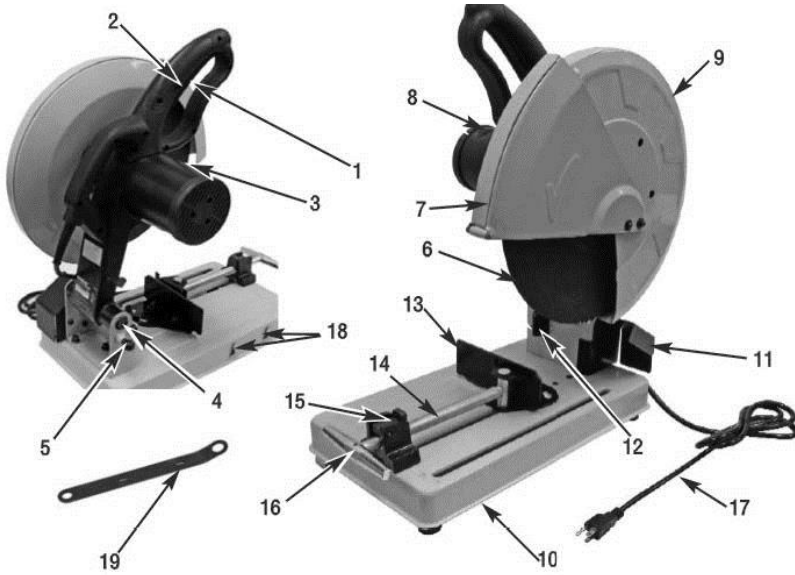

Fig.1

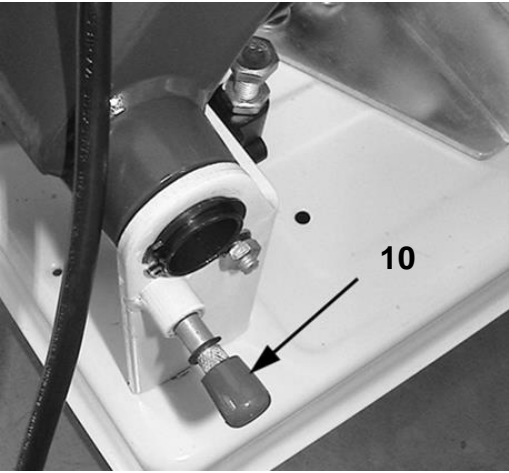

Fig.2

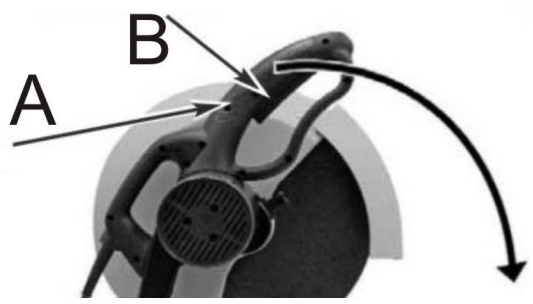

Fig.3

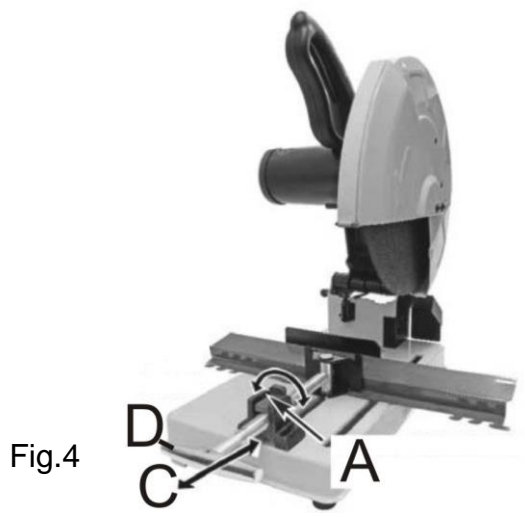

Fig.4

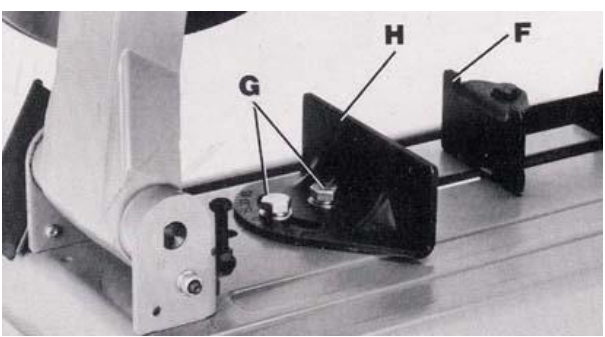

Fig.5

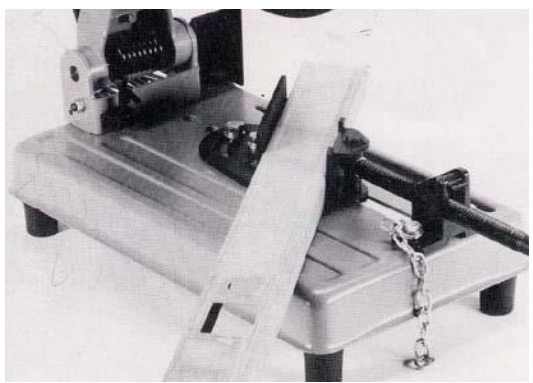

Fig.6

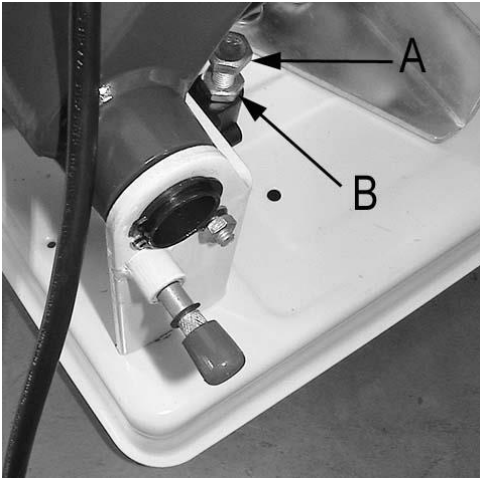

Fig.7

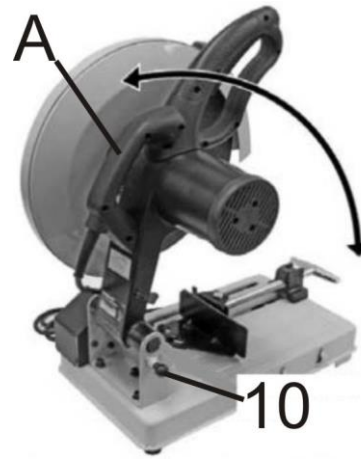

Fig.8

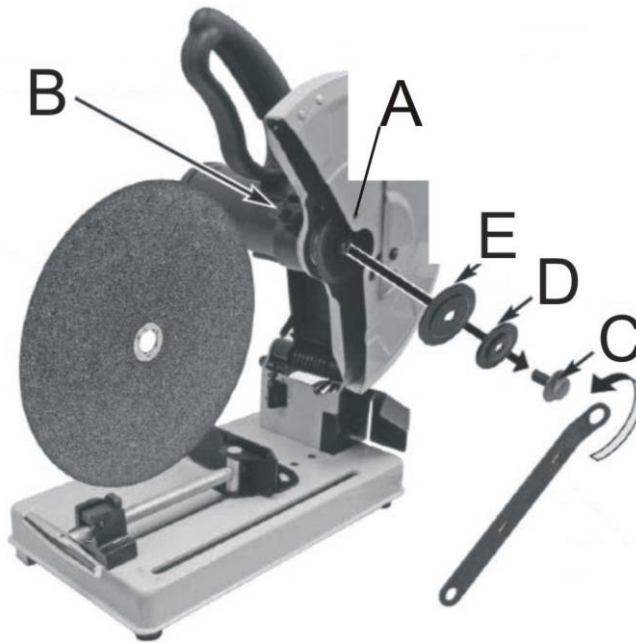

Fig.9

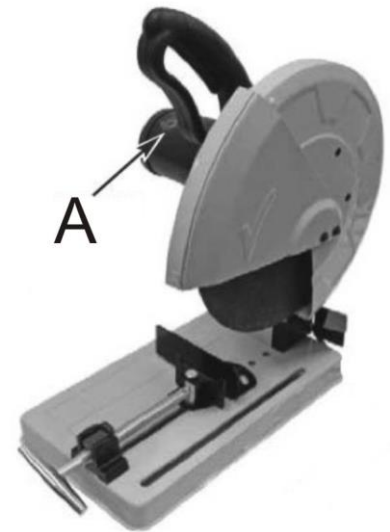

Fig.10

## REMOVAL OF PACKAGE

The cut-off saw is delivered completely assembled inside the package.

Remove the cut-off saw from the package, check that nothing is missing or damaged.

In case there are any faulty or damaged parts do not use it in order not to compromise the efficiency and the safety of the machine. Address to an authorised after-sales centre to change faulty parts.

## MACHINE DESCRIPTION

The cut-off saw F20-140A cuts all ferrous materials.

The 2000 W powerful engine allows you to cut rapidly. The fixed metal protective cap and the metal-sheet moving ones constitute the protective devices for the user. The lock clamp can turn from 0 to 45° for angle cuts (**Fig.1**).

1. Trigger switch
2. Safety button
3. Arbor lock lever
4. Arm stop
5. Arm release knob
6. Abrasive wheel
7. Lower guard
8. Motor
9. Upper Guard
10. Base
11. Spark shield
12. Depth cutting adjustment screw
13. Fence
14. Adjustable vise handle
15. Quick release lever
16. Adjustable vise handle
17. Grounded power cord
18. Wheel wrench holder
19. Wheel wrench

## HEAD LOCK PIN

Inside the package the cut-off saw has the head lowered and is kept in this position by the pin 10 (**Fig.2**) indicated by the arrow in the side figure. To unlock it push the head lightly downwards, pull the pin to the exterior and raise the head. You must lock the head in a low position also before transport.

## **CONTROLS AND ADJUSTMENTS**

### **ON/OFF SWITCH (Fig.3)**

The cut-off saw is provided with an ON/OFF switch that is located on the handle of the machine. To start the saw, push button A first, then push button B. To stop it, release button B.

### **VICE (Fig.4)**

You can rapidly and easily block the piece through the vice as explained below:

1. Raise the part (A) that frees the threaded pin (C).
2. Extract the screw (C) with the handle (D) enough for placing the workpiece in the opening of the clamp and against the fixed jaw. NOTICE: when the half nut (A) is raised the pin (C) is free and it is not necessary to screw it to move it, it is enough to pull it or push it.
3. Make the moving jaw come into contact with the workpiece by pushing the handle (D) inside.
4. Put the part (A) in its initial position, and through the handle (D), screw it to properly block the workpiece in the vice.

### **ANGLE CUT (Fig.5 - 6)**

1. Loosen the two hexagonal screws (G) and turn the back fixed jaw (H) according to the desired angle (from 0 to 45°). Then tighten the two hexagonal screws (G). The front part of the vice (F) will turn and will automatically align with the workpiece during the blocking of the workpiece.
2. The following figure illustrates the workpiece blocked in the vice for a typical operation of angle cut.

### **ADJUSTMENT OF THE LOWERING OF THE DISC (Fig.7)**

You can use the screw (A) for lowering the abrasive disc. To adjust it you must loosen the nut (B), tighten or loosen the screw (A) clockwise or anti-clockwise according to your needs and then block the counter-nut again (B).

You must carry out this adjustment to adapt cutting capacity to the consumption of the disc and when assembling a new disc, in order to avoid cutting the base.

### **TRANSPORT HANDLE (Fig.8)**

To transport the tool, you must block the head down through the locking pin 10, then use the handle illustrated in the picture to lift it and move it.

## FUNCTIONING

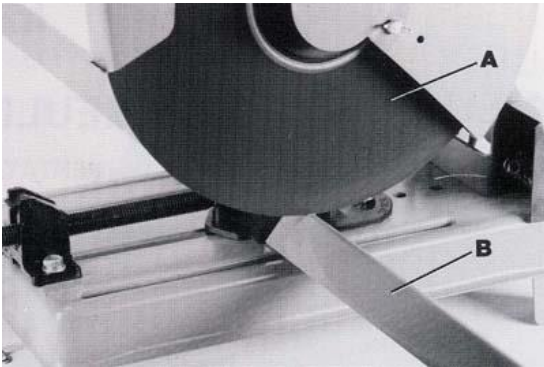

After correctly blocking the piece to be cut in the vice, start the machine and let the motor run at its maximum speed. Slowly lower the disc (A), until it comes into contact with the piece to be cut (B). Exert a constant pressure on the disc to avoid any skipping that could make the disc oval and thus compromise cutting quality and also break the disc.

The result is better when the workpiece is placed in order that the disc cuts with a minimum contact arc.

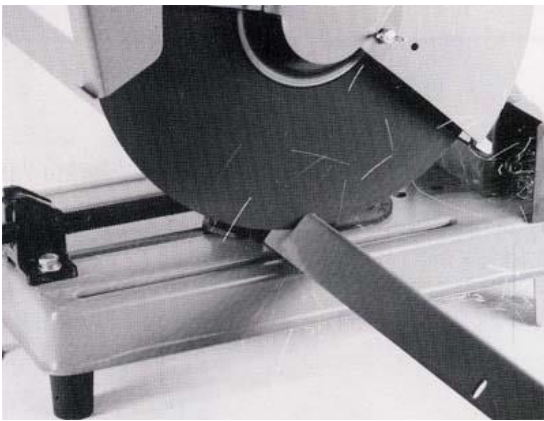

Keep on exerting a constant pressure during cutting.

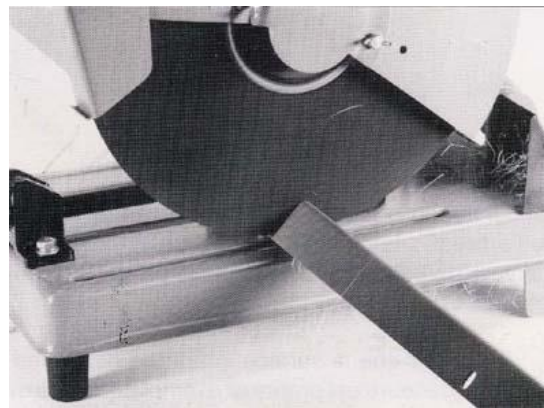

Keep on exerting the same pressure also when you are about to finish the cutting. Normally when you are finishing the cutting the contact arc between the disc and the material to be cut increases and this would require an even greater push.

A slowdown would involve an overheating of the metal and big burrs would appear.

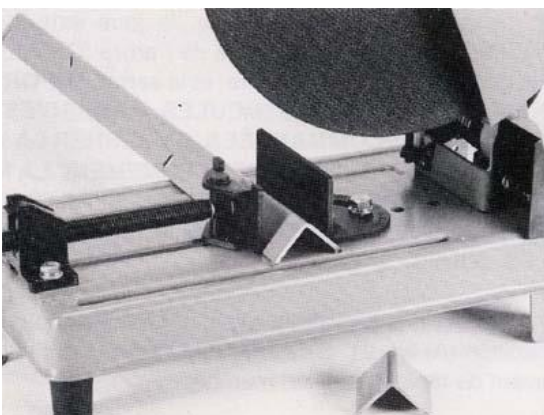

The figure illustrates the piece cut at the end of the work. **Caution:** During work the disc wears out and must be replaced. The number of cuttings you can carry out with the disc, so as cutting quality can considerably vary depending on how the cuttings are carried out. Quick cuttings wear the disc faster but reduce the burrs and workpiece's colouring. This is visible especially when cutting small-bore pipes.

## **REPLACEMENT OF THE DISC (Fig.9)**

**CAUTION:** Switch off the cut-off saw and disconnect it from the current, by removing the plug from the socket before any adjustment, repair, maintenance work, cleansing and before replacing the disc.

1. **DISCONNECT THE TOOL FROM THE POWER SUPPLY.**
2. On the exterior of the fixed protective cap, loosen the screw that fix the circular cover in the central area of the disc, in order to access to the disc lock crew.
3. Move the lower moving protective cap by hand inside the fixed one.
4. Press the lock button of the axle (**B**), indicated by the arrow, and make the abrasive disc turn until the axle is blocked.
5. Through the provided wrench, loosen the lock screw (**C**), by turning it anti-clockwise; remove the screw (**C**), the washer (**D**), the external flange (**E**) and the abrasive disc.  
**DO NOT REMOVE THE INNER FLANGE OF THE DISC.**
6. Be sure that the surfaces of the inner and external flanges are clean.
7. Position the new disc, the outside flange (**E**), the washer (**D**) and tighten the screw (**C**);  
**suitably tighten the lock screw to prevent the disc from skidding, while at same time being careful not to damage the disc by deforming the contact surface because of a too big hold.**

**IMPORTANT: ONLY USE REINFORCED ABRASIVE DISCS, RECOMMENDED AND WITH A NOT EXPIRED VALIDITY DATE.**

8. Lower the moving protective cap and put the cover again and fix it with the screw.
9. Start the machine for a while to check if the disc is correctly assembled and that it does not touch any parts of the tool.

## **MAINTENANCE**

**CAUTION:** Before any adjustment, repair or maintenance work, and before changing the disc, switch off the machine and disconnect it from any current source by removing the plug from the socket.

In case you find out any damage to the protection devices or irregularities while processing or checking the machine, you must get it repaired immediately by qualified persons.

Before use check that the protection and safety devices are perfectly efficient. After carrying out the work, make a general cleaning of the machine.

Periodically clean the ventilation inlets of the engine.

Be sure that the protective cap can slide freely.

Be sure that the head and the clamp can smoothly lift and lower.

Check the noise of the engine periodically and brushes' consumption.

Periodically check that the supply cable is not damaged.



## **CHECK AND REPLACEMENT OF CARBON BRUSHES (Fig.10)**

**CAUTION:** Before checking the carbon brushes, disconnect the machine from the power supply.

The life of the carbon brushes can vary, and it depends on the motor working load. If the tool is new or after the replacement of the carbon brushes, check the carbon brushes after the first 50 hours of use.

After the first check, you must control the carbon brushes every 10 hours of use until it is necessary to replace them.

The housing of the carbon brushes (**A**) are positioned on each side of the motor. Change both the carbon brushes if the carbon of one of the brushes is worn and it is smaller than 5 mm, or in case a spring or a wire is burnt or damaged. If the carbon brushes are still usable after the inspection, re-assemble them on their original position.

## **MALFUNCTIONS**

### **The cut-off saw does not start:**

- The electric current is missing in the socket to which the supply cable is connected.
- The supply cable is faulty
- The engine is damaged or the carbon brushes must be replaced
- The thermal cut-out has started

### **Vibrations on the machine**

- The disc is not properly fixed

### **The engine does not work properly:**

(excessive heating, exaggerate twinkle of the carbon brushes and consequent noise accentuation)

- The engine may be damaged: get the machine checked by an electrician
- Carbon brushes must be replaced

## **SERRACON GUARANTEE**

SERRACON takes a pride in the quality of the power tools it supplies. The component parts of our tools are inspected at various stages of production and each finished tool is subjected to a final check before being packaged for shipment. Because of our confidence in our engineering quality, SERRACON agrees to repair or replace any part or parts of FOX Power Tools and accessories which, upon examination, prove to be defective in workmanship or material. The warranty period for the FOX branded products is one year for parts and labour and three years for parts only. The guarantee does not include repair, labour or parts requiring replacement because of misuse, abuse, or normal wear and tear. Repairs made by other than the factory, SERRACON service centre or authorised FOX service dealers relieves SERRACON of further liability under this guarantee. THIS GUARANTEE IS MADE EXPRESSLY IN PLACE OF ALL OTHER GUARANTEES OR WARRANTIES, EXPRESSED OR IMPLIED, WITH RESPECT TO QUALITY, MERCHANTABILITY, OR FITNESS FOR A PARTICULAR PURPOSE.



CE DECLARATION OF CONFORMITY OF THE MANUFACTURER

SERRACON

WHEATFIELD ROAD

DUNNIKIER BUSINESS PARK

KIRKCALDY, UK, KY1 3PD

Tel. +44 (0) 1592 652946 Fax: +44 (0) 1592 654854

Declares that the: CUT-OFF SAW (F20/140A)

is in compliance with the regulations included in the Directives: CEE 2006/42-2004/108-2006/95

Person authorized to create the technical file: **Robert Paterson**

---

CE

06.05.2011

---

The Director

*Robert Paterson*

F20-140A  
CUT-OFF SAW

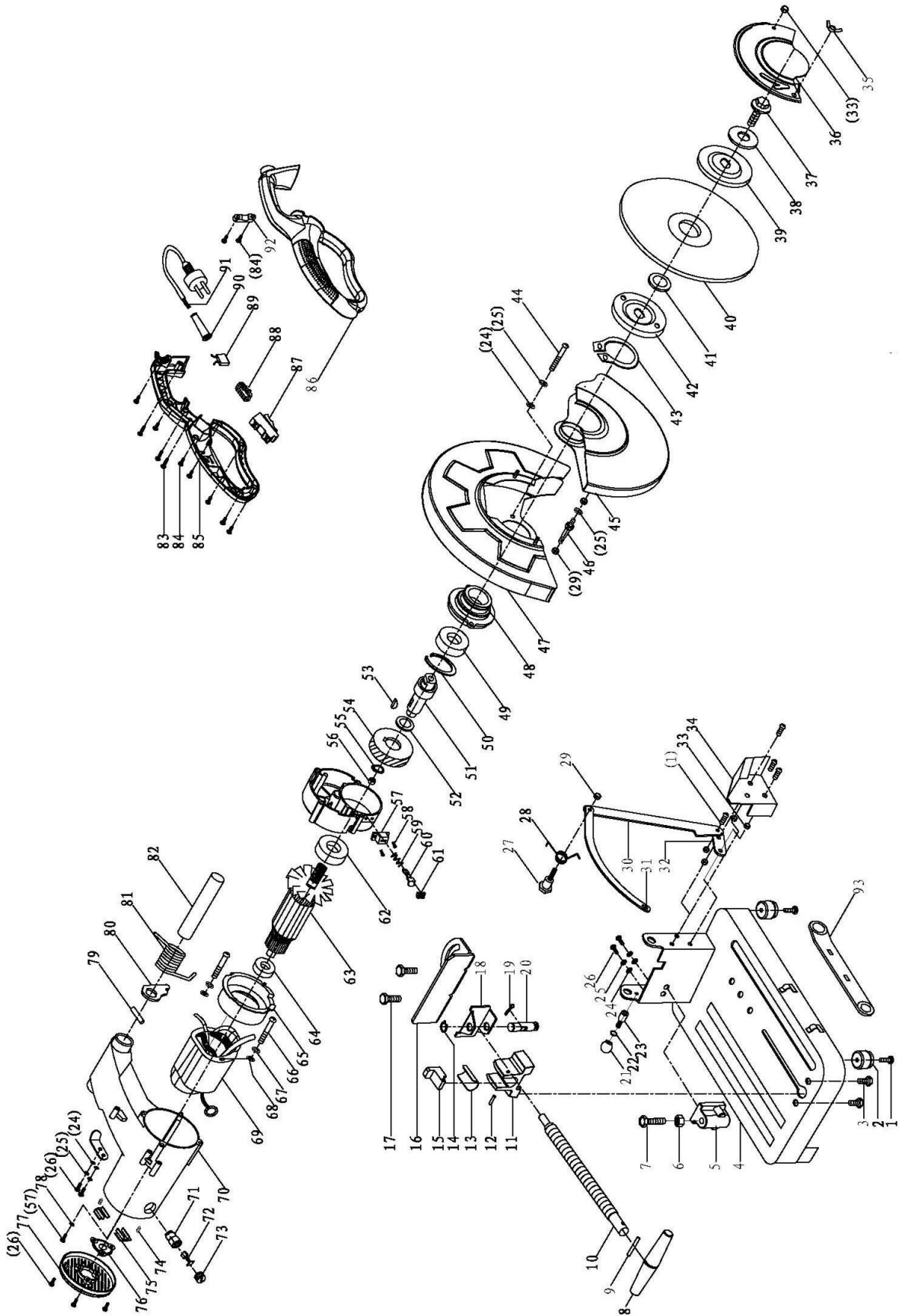



## F20-140A CUT-OFF SAW

NO	REF NO	NO	REF NO
1	F20140A-1	54	F20140A-54
2	F20140A-2	55	F20140A-55
3	F20140A-3	56	F20140A-56
4	F20140A-4	57	F20140A-57
5	F20140A-5	58	F20140A-58
6	F20140A-6	59	F20140A-59
7	F20140A-7	60	F20140A-60
8	F20140A-8	61	F20140A-61
9	F20140A-9	62	F20140A-62
10	F20140A-10	63	F20140A-63
11	F20140A-11	64	F20140A-64
12	F20140A-12	65	F20140A-65
13	F20140A-13	66	F20140A-66
14	F20140A-14	67	F20140A-67
15	F20140A-15	68	F20140A-68
16	F20140A-16	69	F20140A-69
17	F20140A-17	70	F20140A-70
18	F20140A-18	71	F20140A-71
19	F20140A-19	72	F20140A-72
20	F20140A-20	73	F20140A-73
21	F20140A-21	74	F20140A-74
22	F20140A-22	75	F20140A-75
23	F20140A-23	76	F20140A-76
24	F20140A-24	77	F20140A-77
25	F20140A-25	78	F20140A-78
26	F20140A-26	79	F20140A-79
27	F20140A-27	80	F20140A-80
28	F20140A-28	81	F20140A-81
29	F20140A-29	82	F20140A-82
30	F20140A-30	83	F20140A-83
31	F20140A-31	84	F20140A-84
32	F20140A-32	85	F20140A-85
33	F20140A-33	86	F20140A-86
34	F20140A-34	87	F20140A-87
35	F20140A-35	88	F20140A-88
36	F20140A-36	89	F20140A-89
37	F20140A-37	90	F20140A-90
38	F20140A-38	91	F20140A-91
39	F20140A-39	92	F20140A-92
40	F20140A-40	93	F20140A-93
41	F20140A-41		
42	F20140A-42		
43	F20140A-43		
44	F20140A-44		
45	F20140A-45		
46	F20140A-46		
47	F20140A-47		
48	F20140A-48		
49	F20140A-49		
50	F20140A-50		
51	F20140A-51		
52	F20140A-52		
53	F20140A-53		

WIRING DIAGRAM

