

Champion®



ELECTRIC FAN HEATERS

Devil 6002, 6003, 6005, 6009 & 6015

Part Nos: 6925218, 6925220, 6925225, 6925230 & 6925235

OPERATING & MAINTENANCE INSTRUCTIONS



GC0414

INTRODUCTION

Thank you for purchasing this CLARKE Electric Fan Heater.

Please read this manual thoroughly and follow the instructions carefully. Before attempting to use the heater, thoroughly familiarise yourself with the heater & its operation. In doing so you will ensure the safety of yourself and that of others around you, and you can look forward to the heater giving you long and satisfactory service.

GUARANTEE

This product is guaranteed against faulty manufacture for a period of 12 months from the date of purchase. Please keep your receipt which will be required as proof of purchase.

This guarantee is invalid if the product is found to have been abused or tampered with in any way, or not used for the purpose for which it was intended.

Faulty goods should be returned to their place of purchase, no product can be returned to us without prior permission.

This guarantee does not effect your statutory rights.

ENVIRONMENTAL PROTECTION



Through purchase of this product, the customer is taking on the obligation to deal with the WEEE in accordance with the WEEE regulations in relation to the treatment, recycling & recovery and environmentally sound disposal of the WEEE.

In effect, this means that this product must not be disposed of with general household waste. It must be disposed of according to the laws governing Waste Electrical and Electronic Equipment (WEEE) at a recognised disposal facility.

TABLE OF CONTENTS

INTRODUCTION	2
GUARANTEE	2
ENVIRONMENTAL PROTECTION	2
SPARE PARTS & SERVICING CONTACTS	2
TABLE OF CONTENTS	3
GENERAL SAFETY RULES	4
ELECTRICAL CONNECTIONS	6
OPERATION	8
MAINTENANCE	10
FAULT FINDING	11
PARTS LISTS & DIAGRAMS	12
TECHNICAL SPECIFICATION	17
DECLARATIONS OF CONFORMITY	18

GENERAL SAFETY RULES

WORK AREA

1. These heaters are for INDOOR USE ONLY.
2. Do not expose the heater or power cable to rain or wet conditions. Any water entering the heater will increase the risk of electric shock. DO NOT use this heater in a bathroom, shower room, in the vicinity of a swimming pool, or any wet environment.
3. NEVER locate the heater near combustible materials such as curtains, furniture etc. Allow at least 1 metre clearance.
4. DO NOT locate the heater close to an adjacent wall or ceiling. Allow a distance of at least 1 metre from a wall or ceiling. Avoid placing the heater directly below socket outlets.
5. Take care to ensure that the grille cannot be blocked by curtains or other fabrics.
6. Do not operate fan heaters in explosive atmospheres such as in the presence of flammable liquids, gases or dust such as in a paint spray booth or any explosive environment. Electric motors create sparks which may ignite dust or fumes.
7. Never place the heater on a movable vehicle where it could be tipped over.
8. Do not allow the heating elements to become covered with dust which could become a fire hazard. If used in a dusty workplace it should be cleaned as described under Cleaning and Maintenance.
9. NEVER touch the heater element for at least 15 minutes after switching off.
10. DO NOT leave the heater unattended.
11. If children are present always use with a fireguard.
12. Store the fan heater out of the reach of children and do not allow persons unfamiliar with these instructions to operate this appliance.
13. Do not use this heater with a programmable timer used to switch it on automatically.

ELECTRICAL SAFETY

1. Electrical appliances must match the power outlet. Never modify the plug in any way. Do not use adaptor plugs with earthed (grounded) appliances. Correct plugs and outlets will reduce the risk of electric shock.
2. Do not abuse the electrical cable. Never use the cable for pulling or unplugging the heater. Keep the cable away from sources of heat, oil, sharp edges or moving parts. Damaged or tangled cables increase the risk of electric shock.

3. Keep the mains cable well away from machines and ensure an adequate electrical supply is close at hand so that the operation is not restricted by the length of the cable.
4. ALWAYS disconnect from the mains supply before moving the heater or performing any maintenance tasks.
5. ALWAYS use ONLY in an upright position.
6. Inspect the mains cable regularly for signs of damage. DO NOT use if it is damaged, and ALWAYS keep it away from the source of heat.
7. Check the fan heater for damage before use. DO NOT use if the heater elements are damaged or broken. Any damage should be properly repaired or the part replaced. If in doubt, **DO NOT** use the machine. Consult your local dealer.



WARNING! Do not operate the Devil 6003 heater in conjunction with an extension cable.

SERVICE & REPAIRS

1. When necessary, have your appliance repaired by a qualified person using identical replacement parts. This will ensure that the safety of the appliance is maintained.

Please keep these instructions in a safe place for future reference.

ELECTRICAL CONNECTIONS

DEVIL 6002 (2KW)AND 6003 (3KW) HEATER UNITS

These models are provided with a 13 amp BS 1363 plug, fitted with a 13amp fuse and MUST be connected to a standard, 230 Volt (50Hz) electrical supply, preferably through an approved plug, or a suitably fused isolator switch.



WARNING! Read these electrical safety instructions thoroughly before connecting the product to the mains supply.

Before switching the machine on, make sure that the voltage of your electricity supply is the same as that indicated on the rating plate. This product is designed to operate on 230 VAC mains power. Connecting it to any other power source may cause damage.



WARNING! Do not operate the Devil 6003 heater in conjunction with an extension cable.

This product may be fitted with a non-rewireable plug. If it is necessary to change the fuse in the plug, the fuse cover must be refitted. If the fuse cover becomes lost or damaged, the plug must not be used until a suitable replacement is obtained.

If the plug has to be changed because it is not suitable for your socket, or due to damage, it should be cut off and a replacement fitted, following the wiring instructions shown below. The old plug must be disposed of safely, as insertion into a mains socket could cause an electrical hazard.



WARNING! The wires in the power cable of this product are coloured in accordance with the following code:

Blue = Neutral Brown = Live Yellow and Green = Earth

If the colours of the wires in the power cable of this product do not correspond with the terminal markings of your plug, proceed as follows.

- The wire which is coloured **Blue** must be connected to the terminal which is marked N or coloured **Black**.
- The wire which is coloured **Brown** must be connected to the terminal which is marked L or coloured **Red**.
- The wire which is coloured **Yellow and Green** must be connected to the terminal which is marked E or  or coloured **Green**.

Plug must be BS1363/A approved

Earth
(Green and Yellow)

Neutral
(Blue)

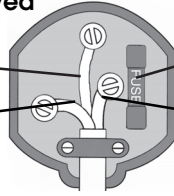

Always fit a 13 Amp fuse.

Live
(Brown)

Ensure that the outer sheath of the cable is firmly held by the clamp

We strongly recommend that this machine is connected to the mains supply via a Residual Current Device (RCD).

If in doubt, consult a qualified electrician. DO NOT attempt repairs yourself.

DEVIL 6005 (5KW), DEVIL 6009(9KW) AND DEVIL 6015(15KW) UNITS

These machines MUST be connected to a 400 Volt, 3 PHASE 50Hz supply through a suitably fused isolator switch. They cannot be operated from a single phase supply.

The user should purchase a suitable connecting lead as shown in the diagram, which is compatible with the appliance socket. The unit requires 5 pins including a master earth pin, and is suitable for AC 380/415v, 50/60Hz with a capacity of 16A/6h (Devil 6005 and 6009) or 32A/6h (Devil 6015) and rated at IP44 class (or better) insulation. A length of 2-3 metres is recommended as giving mobility to the appliance but without becoming a trip hazard.

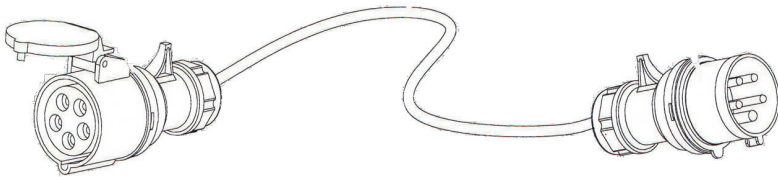

The plug incorporates a hood which will secure the cable in position when engaged with the appliance.

If in any doubt, consult a qualified electrician. DO NOT attempt any electrical repairs yourself.

OPERATION

The Devil range of fan assisted electric heaters are suitable for household (Devil 6002 & 6003 only) or workshop/factory use. They incorporate a thermostat which detects the temperature of the room air and controls the heater to maintain a pre-selected temperature between 0 & 40°C. A manually reset thermal cutout is provided for safety in the event of overheating on the 6005, 6009 & 6015 models. The 2kw and 3kw units are fitted with a self-resetting thermal cutout. The fan motor runs independently of the thermostat and continues running after the heating element has been switched off.

With the heater sited on a firm level surface and at a safe distance from flammable objects (in compliance with all safety precautions), plug the heater into the mains and set the thermostatic control to the maximum temperature setting. Switch the heater on to one of the following power settings. Once the room reaches the required temperature, you should turn the thermostatic control slowly anti-clockwise until the heater switches off. The heater will now start and stop automatically to maintain the room temperature.

2 KW HEATERS

The 2kw heater has three settings for 1) fan plus single heating element, 2) fan plus two heating elements and 3) fan plus all three heating elements. The other control is a progressive thermostat which is rotated through 270 degrees. A cutout is used to maintain a constant pre-set temperature.

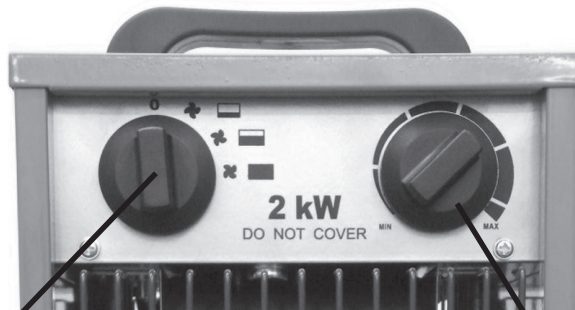

**3-position fan speed /
temperature control**

Thermostatic temperature control

3 KW HEATERS

The 3kw heater has three settings for 1) fan only, 2) fan plus single heating element, 3) fan plus both heating elements. The other control is a progressive thermostat which is rotated through 270 degrees. A cutout is used to maintain a constant pre-set temperature.

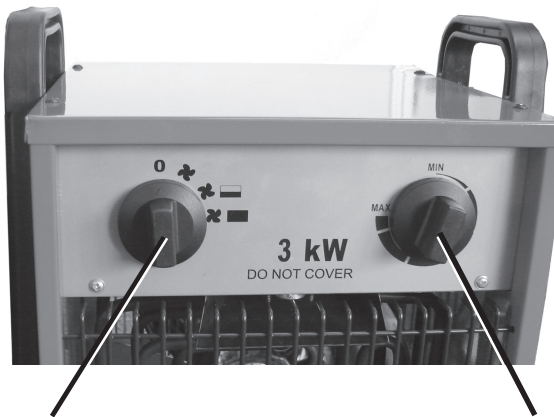

3-position fan speed control

**thermostatic
temperature control**

The thermostat will then switch the heater on and off automatically to control the room temperature according to the pre-set value, maintaining a constant room temperature.

When using the heater to warm a cold room, first turn the thermostat to MAX and run the heater on full power until the room temperature reaches the required value, then turn the thermostat anti-clockwise until it switches off.

When using the heater for the first time a slight emission of smoke may be noticed. This is quite normal and soon stops. It is caused by residual traces of oil remaining on the element from production.

After use, turn the thermostat to the OFF position and turn the selector switch to the Fan Only position, and leave the unit to cool down for a couple of minutes.

5KW, 9KW & 15KW HEATERS

The 5 & 9kw units have a three-position twist control for FAN only, and FAN plus either half or full heat output. The 15kw unit has a four position control;- FAN only, FAN + 1/3, FAN + 2/3 & FAN + full heat output. A thermostatic temperature control is also provided for fine control of heat output at a constant pre-set temperature.

Should the heater overheat, a thermal cutout will operate, shutting down the unit. If this happens, allow time for the unit to cool (approx. 10 minutes) before pressing the RESET using a suitable tool, and restarting the heater.

When switching the unit OFF, it is strongly recommended that the unit is run in the FAN ONLY mode for approx. 10 minutes, in order to cool the heating elements, before switching OFF completely and finally disconnecting from the mains supply.



**3-position fan speed /
temperature control**

**Thermostatic temperature
control**

The thermal cutout may also operate if the heater is shut down without allowing to cool sufficiently. If subsequently, the heater fails to start, press the RESET using a suitable tool and try again.

MAINTENANCE

If the heater has been used, ALWAYS allow it to cool down for at least 10 minutes (by switching the heater off, but leave the fan running), then disconnect from the mains supply before performing any maintenance tasks.

PERIODICALLY

- Disconnect from the mains supply, and use compressed air to clean out the unit. ALWAYS wear a dust mask to perform this operation.
- If there is any serious build up of dirt, wipe thoroughly with a damp cloth. Take care that no moisture enters the heater.
- Inspect the mains cable for damage. Heat damage will cause the cable to stiffen and crack. If this is found, have the cable replaced. Check the cable routing and ensure it is well away from the heat source.
- Ensure the heating elements are clear of dust (use compressed air to clean the heater if possible).
- Avoid using solvents when cleaning plastic parts, most plastics are susceptible to damage from various types of commercial solvents.
- Refer to your Clarke dealer if internal maintenance is required. The unit is fitted with tamper-proof screws to discourage users from dismantling the heater.
- When storing the heater, allow it to cool down, then cover it with its plastic bag and place it in its packing box for storage in a dry, well ventilated place.

FAULT FINDING

Problem	Possible cause	Remedy
Heater does not operate, although plugged in with the switch and thermostat switched on.	Plug is loose/bad connection.	Pull the plug out & check the connection of the plug and socket.
	Fuse blown.	Replace if necessary and investigate cause. If fuse blows repeatedly, consult your Clarke dealer.
	No power at socket outlet.	Insert the plug in a suitable socket.
Heating element glowing hot.	Input voltage too high or too low.	Use a power supply in accordance with the rating on the label.
	Air inlet grille is blocked	Ensure the heater is kept away from any objects which could cover the air inlet or be drawn into it.
The unit failed to heat up so only the air fan operated.	Control switch not set at a "HEATING" level.	Turn switch to a heating level.
	Thermostat has tripped.	Turn the thermostat and listen. If there is no CLICK and the thermostat is not damaged, the heater will automatically switch ON when it has cooled down.
	The manually reset cut-out has operated.	Disconnect the power. Take a suitable pin and insert it into the manual RESET hole in the control panel. Press the RESET button and connect the circuit.
Abnormal noise.	Heater is not level.	Stand heater on a level surface.

PARTS DIAGRAM DEVIL 6002

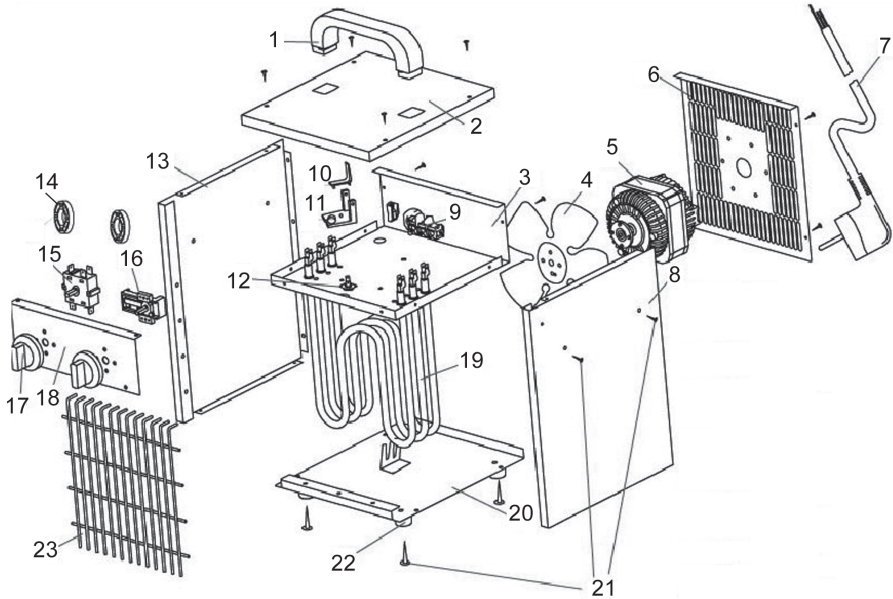

NO	PART CODE	DESCRIPTION	Qty
1	N/A	Handle	1
2	N/A	Top Panel	1
3	N/A	Chassis Panel	1
4	CXDEV600201	Fan	1
5	CXDEV600202	Electric Motor	1
6	N/A	Rear Grill	1
7	CXDEV600203	Power Cable	1
8	N/A	Side Panel (L/H)	1
9	N/A	Power Connector	1
10	N/A	Thermostat Fixing	1
11	N/A	Thermostat Holder	1
12	CXDEV600304	Thermostat	1

NO	PART CODE	DESCRIPTION	Qty
13	N/A	Side Panel (RH)	1
14	N/A	Securing Rings	1
15	CXDEV600207	Switch	1
16	CXDEV600208	Room Thermostat	2
17	CXDEV600209	Control Knob	1
18	N/A	Control Panel	1
19	CXDEV600210	Heating Elements	1
20	N/A	Base Panel	1
21	N/A	Screws	1
22	N/A	Plastic Base	1
23	N/A	Front Grill	1

PARTS DIAGRAM DEVIL 6003

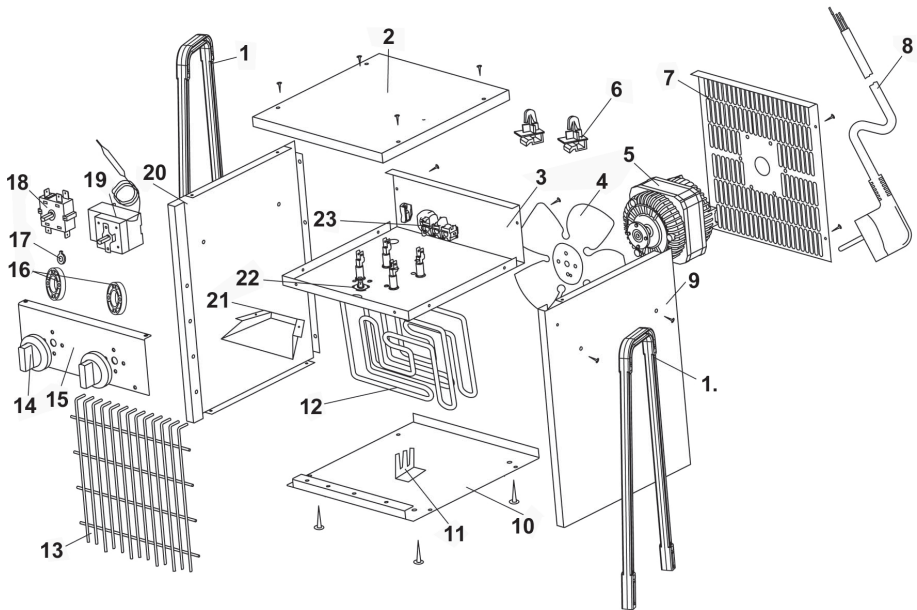

NO	PART CODE	DESCRIPTION	Qty
1	N/A	Support Leg	2
2	N/A	Top Panel	1
3	N/A	Chassis Panel	1
4	CXDEV600301	Fan	1
5	CXDEV600302	Motor	1
6	N/A	Retaining clips	2
7	N/A	Rear Panel	1
8	CXDEV600303	Power Cable	1
9	N/A	Side Panel (RH)	1
10	N/A	Base Panel	1
11	N/A	Heater Bracket	1
12	CXDEV600304	Heating Element	2

NO	PART CODE	DESCRIPTION	Qty
13	CXDEV600305	Front Grille	1
14	CXDEV600306	Fan Control Knob	1
15	N/A	Front Panel	1
16	N/A	Mounting Packer	2
17	N/A	Washer	1
18	CXDEV600307	Power/Fan Speed Controller	1
19	CXDEV600308	Temperature Controller	1
20	N/A	Side Panel (LH)	1
21	N/A	Air Duct	1
22	CXDEV600309	Thermal Cutout	1
23	CXDEV600310	Terminal Block	1

PARTS DIAGRAM DEVIL 6005

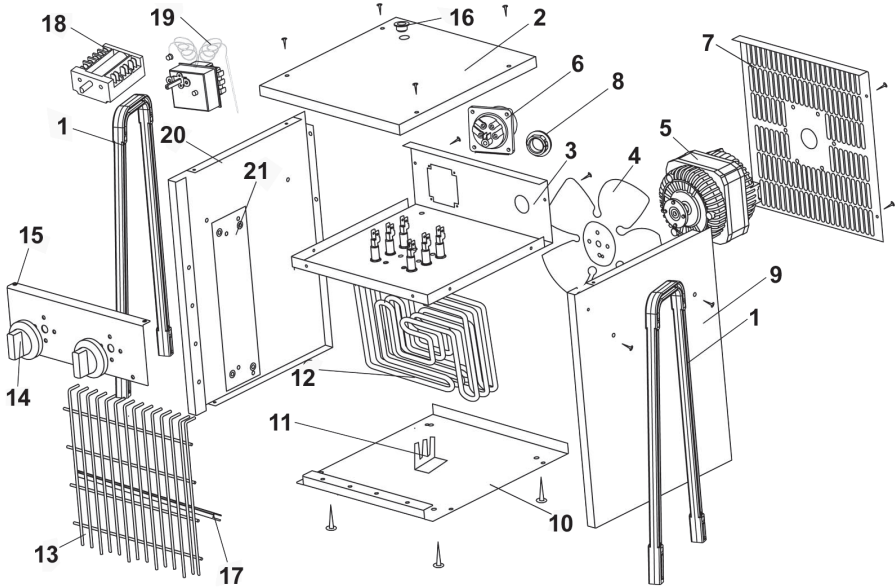

NO	PART CODE	DESCRIPTION	Qty
1	N/A	Support Leg	2
2	N/A	Top Panel	1
3	N/A	Chassis Panel	1
4	CXDEV600501	Fan	1
5	CXDEV600502	Motor	1
6	N/A	5-Pin Socket	1
7	N/A	Rear Panel	1
8	N/A	Cable Entry	1
9	N/A	Side Panel (RH)	1
10	N/A	Base Panel	1
11	N/A	Heater Bracket	1

NO	PART CODE	DESCRIPTION	Qty
12	CXDEV600503	Heating Element	2
13	CXDEV600504	Front Grille	1
14	CXDEV600505	Fan Control Knob	1
15	N/A	Front Panel	1
16	N/A	Plastic Plug	1
17	N/A	Support Bar	1
18	CXDEV600506	Power/Fan Speed Controller	1
19	CXDEV600507	Temperature Controller	1
20	N/A	Side Panel (LH)	1
21	N/A	Heat Shield	2

PARTS DIAGRAM DEVIL 6009

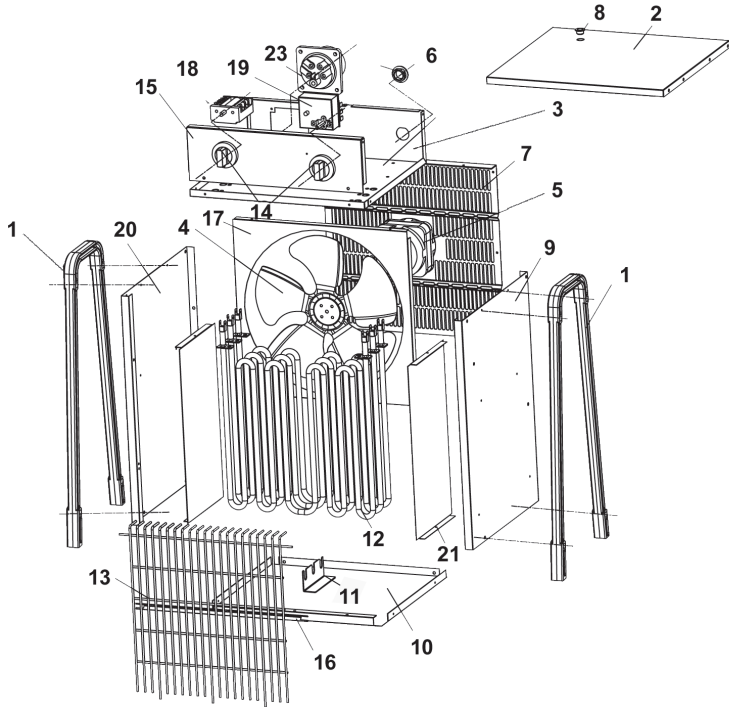

NO	PART CODE	DESCRIPTION	Qty
1	N/A	Support Leg	2
2	N/A	Top Panel	1
3	N/A	Chassis Panel	1
4	CXDEV600901	Fan	1
5	CXDEV600902	Motor	1
6	N/A	Cable Entry	2
7	N/A	Rear Panel	1
8	N/A	Plastic Plug	1
9	N/A	Side Panel (RH)	1
10	N/A	Base Panel	1
11	N/A	Heater Bracket	1

NO	PART CODE	DESCRIPTION	Qty
12	CXDEV600903	Heating Element	2
13	CXDEV600904	Front Grille	1
14	CXDEV600905	Control Knob	2
15	N/A	Front Panel	1
16	N/A	Support Bar	1
17	N/A	Closing Panel	1
18	CXDEV600907	Power/Fan Speed Controller	1
19	CXDEV600908	Temperature Controller	1
20	N/A	Side Panel (LH)	1
21	N/A	Heat Shield	2

PARTS DIAGRAM DEVIL 6015

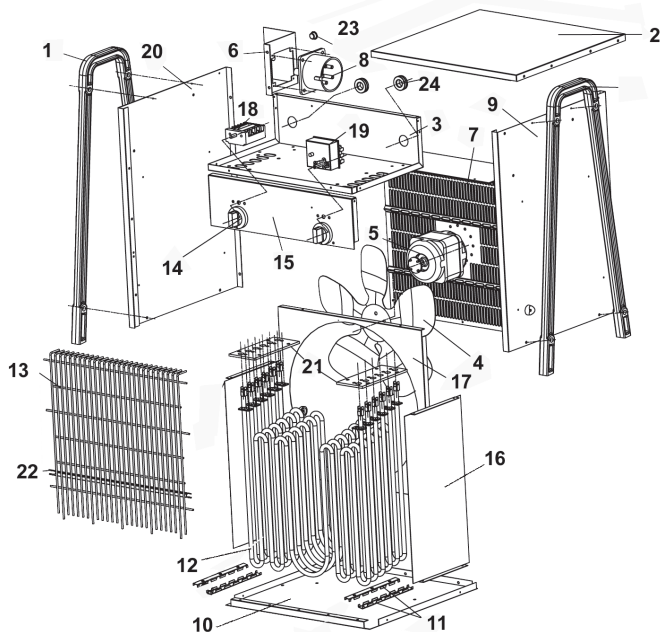

NO	PART CODE	DESCRIPTION	Qty
1	N/A	Support Leg	2
2	N/A	Top Panel	1
3	N/A	Chassis Panel	1
4	CXDEV601501	Fan	1
5	CXDEV601502	Motor	1
6	N/A	Angle Bracket	1
7	N/A	Rear Panel	1
8	N/A	5-Pin Socket	1
9	N/A	RH Side Panel	1
10	N/A	Base Panel	1
11	N/A	Heater Bracket	1
12	CXDEV601503	Heating Element	6

NO	PART CODE	DESCRIPTION	Qty
13	CXDEV601504	Front Grille	1
14	CXDEV601505	Control Knob	1
15	N/A	Front Panel	1
16	N/A	Heat Shield	2
17	N/A	Closing Plate	1
18	CXDEV601506	Speed Controller	1
19	CXDEV601507	Temperature Controller	1
20	N/A	LH Side Panel	1
21	N/A	Heater Retainer	2
22	N/A	Supporting bar	1
23	N/A	Plug	1
24	N/A	Bush	2

TECHNICAL SPECIFICATION

Item	Published Specification				
Model	Devil 6002	Devil 6003	Devil 6005	Devil 6009	Devil 6015
Part No	6925218	6925220	6925225	6925230	6925235
Weight	3.6 kg	5.5 kg	7.0 kg	9.0 kg	14.4 kg
Dimensions (d x w x h) mm	225x200x425	295x265x425	295x305x25	350x335x465	400x345x535
Input Wattage (kw)	0.025kw(fan only) 0.6kw(setting 1) 1.3kw(setting 2) 2kw(setting 3)	1.5(setting 1) 3.0(setting 2)	2.5(setting 1) 5.0(setting 2)	4.5(setting 1) 9.0(setting 2)	95w(fan only) 5kw(setting 1) 10kw(setting 2) 15kw(setting 3)
Input Amperage	0.2 (fan only) 2.9kw(setting 1) 5.7kw(setting 2) 8.6kw(setting 3)	6.4(setting 1) 12 (setting 2)	7.2	13	21.65
Input Voltage	230v / 50 Hz	230v / 50 Hz	400v / 50 Hz	400v / 50 Hz	400v / 50 Hz
Fuse Rating	13A	13A	16A	16A	32A
Air Output	120 m ³ /h	512 m ³ /h	557 m ³ /h	773 m ³ /h	1559 m ³ /h
Sound Level	n/a	51 or <70dB(A)	51 or <70dB (A)	59 or <70dB (A)	64 or <70dB (A)
InsulationClass	IPX4	IPX4	IPX4	IPX4	IPX4
Heat Output	2 kw	3 kw	5 kw	9 kw	15 kw
Operating Temperature	0 - 85°C	0 - 40°C	0 - 40°C	0 - 40°C	0 - 40°C

Please note that the details and specifications contained herein, are correct at the time of going to print. However, CLARKE International reserve the right to change specifications at any time without prior notice.

DECLARATION OF CONFORMITY



Clarke[®]
INTERNATIONAL

Hemnoll Street, Epping, Essex CM16 4LG

DECLARATION OF CONFORMITY

This is an important document and should be retained.

We hereby declare that this product(s) complies with the following directive(s):

2004/108/EC *Electromagnetic Compatibility Directive.*

2006/95/EC *Low Voltage Equipment Directive.*

2002/95/EC *Restriction of Hazardous substances.*

The following standards have been applied to the product(s):

EN 60335-2-30:2003+A1:04+A2:07, EN 60335-1:2002+A11,A1:04+A12,A2:06+A13:08,

EN 62233:2008, EN 55014-1:2006, EN 55014-2:1997/A1:2001, EN 61000-3-2:2006,

EN 61000-3-3:1995/A1:2001/A2:2005

The technical documentation required to demonstrate that the product(s) meet(s) the requirement(s) of the aforementioned directive(s) has been compiled and is available for inspection by the relevant enforcement authorities.

The CE mark was first applied in: 2009

Product Description: 2Kw Fan Heater

Model number(s): Devil 6002

Serial / batch Number: N/A

Date of Issue: 19/04/2011

Signed:

J.A. Clarke
Director

DECLARATION OF CONFORMITY



DECLARATION OF CONFORMITY

This is an important document and should be retained.



We declare that this product complies with the following directives:

2004/108/EC *Electromagnetic Compatibility directive*

2006/95/EC *Low Voltage Equipment directive*

2002/95/EC *Restriction of Hazardous substances*

The Following Standards have been applied to the product:

EN 55014-1:2000/A1:2001/+A2:2002 EN 55014-2 1997/+A1:2001

EN 61000-3-2:2000/+A2:2005 EN 61000-3-3:1995+A1:2001/+A2:2005

EN 60335-1:2002+A11,A1:04+A12+,A2:06 EN 60335-2-30:2003+A1:04

EN 50366:2003+A1:06

The technical documentation required to demonstrate that the products meet the requirements of the Low Voltage Equipment directive has been compiled and is available for inspection by the relevant enforcement authorities.

The CE mark was first applied in: 2007

Product Description: Electric Fan Heaters (3kW, 5kW, 9kW,15kW)

Model number(s): *Devil 6003, 6005, 6009, 6015*

Serial / batch Number: Current Manufacture.

Date of Issue: 02/09/2008

Signed

A handwritten signature in black ink, appearing to read "A. C. Aiken".

A. C. AIKEN

Senior Manager Clarke International.

A SELECTION FROM THE VAST RANGE OF

Clarke®

QUALITY PRODUCTS

AIR COMPRESSORS

From DIY to industrial, Plus air tools, spray guns and accessories.

GENERATORS

Prime duty or emergency standby for business, home and leisure.

POWER WASHERS

Hot and cold, electric and engine driven - we have what you need

WELDERS

Mig, Arc, Tig and Spot. From DIY to auto/industrial.

METALWORKING

Drills, grinders and saws for DIY and professional use.

WOODWORKING

Saws, sanders, lathes, mortisers and dust extraction.

HYDRAULICS

Cranes, body repair kits, transmission jacks for all types of workshop use.

WATER PUMPS

Submersible, electric and engine driven for DIY, agriculture and industry.

POWER TOOLS

Angle grinders, cordless drill sets, saws and sanders.

STARTERS/CHARGERS

All sizes for car and commercial use.

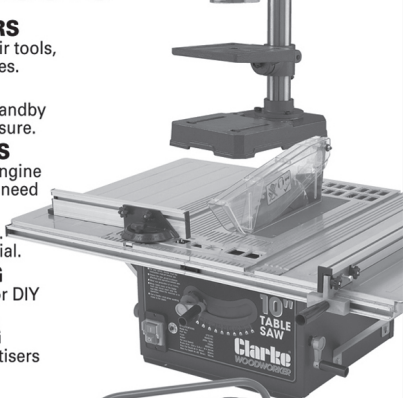

PARTS & SERVICE: 020 8988 7400

E-mail: Parts@clarkeinternational.com or Service@clarkeinternational.com

SALES: UK 01992 565333 or Export 00 44 (0)1992 565335

Clarke® INTERNATIONAL Hemnall Street, Epping, Essex CM16 4LG
www.clarkeinternational.com