

Chantrelle® PUMP



230V DIESEL FUEL TRANSFER PUMP MODEL NO: DFT230

PART NO: 7160050

OPERATION & MAINTENANCE INSTRUCTIONS



GC0816

INTRODUCTION

Thank you for purchasing this CLARKE Pump.

The DFTP230 pump is a self-priming rotary vane pump equipped with a by-pass valve and built-in filter on the inlet side. It is designed only for use with diesel fuels, parafin and light fuel oil. It must not be used with water, petroleum fuels or alcohol, nor if small solids are known to be in suspension.

Before attempting to use this product, please read this manual thoroughly and follow the instructions carefully. In doing so you will ensure the safety of yourself and that of others around you, and you can look forward to your purchase giving you long and satisfactory service.

SPECIFICATIONS

Fluid Classification / Fluids to be used	Clean (parafin, light fuel oil, diesel)
Max. Head	6 m
Max. Flowrate (dependant upon temperature/type of oil)	56 l/min
Duty Cycle	Continuous
Max. Operating Temperature	10 - 70° C
Max liquid temperature	40° C
Weight (complete)	14 kg
Inlet Hose Length	2 m
Outlet Hose Length	2 m
Power cable length	2 m
Motor	230 Vac~50Hz
Input rated power	450 W
IP Rating	IP 54
Thermal overload protection fitted	Yes

Please note that the details and specifications contained herein, are correct at the time of going to print. However, CLARKE International reserve the right to change specifications at any time without prior notice. Always consult the pump's data plate.

SAFETY PRECAUTIONS

Please read all of the safety and operating instructions carefully before using this product. Keep these instructions in a safe place for future reference.

WORK AREA

1. **Keep the work area clean and well lit.** Cluttered and dark areas invite accidents.
2. **Do not operate power products in explosive atmospheres such as in the presence of flammable liquids, gasses or dust.** Power products create sparks which may ignite dust or fumes.

ELECTRICAL SAFETY

1. **Do not abuse the electrical cable. Keep the cable away from sources of heat, oil, sharp edges or moving parts.** Damaged or tangled cables increase the risk of electric shock.

PUMP SAFETY

1. DO NOT use this pump where there is a danger of fire.
2. DO NOT use to pump ANY liquid other than diesel, parafin and light fuel oil.
3. ALWAYS ensure the ON/OFF switch, is in the **OFF (O)** position, **BEFORE** connecting to the battery. This is to avoid the possibility of arcing taking place, thereby reducing the risk of fire.
4. Switch the pump OFF as soon as the task is complete.
5. **Do not use the pump if the switch does not turn it on and off.** Any power product that cannot be controlled with the switch is dangerous and must be repaired.
6. If necessary, have your pump repaired by a qualified person using identical replacement parts. This will ensure that the safety of the product is maintained.

ENVIRONMENTAL PROTECTION

1. Take care to ensure that if diesel fuel is spilt that it is cleaned away using sand or treated with absorbent granules designed for the purpose.
2. Always make every effort to contain any spillage and prevent ingress into the local water course.

ENVIRONMENTAL RECYCLING POLICY



Through purchase of this product, the customer is taking on the obligation to deal with the WEEE in accordance with the WEEE regulations in relation to the treatment, recycling & recovery and environmentally sound disposal of the WEEE.

In effect, this means that this product must not be disposed of with general household waste. It must be disposed of according to the laws governing Waste Electrical and Electronic Equipment (WEEE) at a recognised disposal facility.

GUARANTEE

This CLARKE product is guaranteed against faulty manufacture for a period of 12 months from the date of purchase. Please keep your receipt as proof of purchase. This guarantee is invalid if the product is found to have been abused or tampered with in any way, or not used for the purpose for which it was intended.

Faulty goods should be returned to their place of purchase. No product can be returned to us without prior permission. This guarantee does not effect your statutory rights.

ELECTRICAL CONNECTIONS



WARNING! READ THESE ELECTRICAL SAFETY INSTRUCTIONS THOROUGHLY BEFORE CONNECTING THE PRODUCT TO THE MAINS SUPPLY.

Before switching the product on, make sure that the voltage of your electricity supply is the same as that indicated on the rating plate. This product is designed to operate on 230VAC 50Hz. Connecting it to any other power source may cause damage.

This product may be fitted with a non-rewireable plug. If it is necessary to change the fuse in the plug, the fuse cover must be refitted. If the fuse cover becomes lost or damaged, the plug must not be used until a suitable replacement is obtained.

If the plug has to be changed because it is not suitable for your socket, or due to damage, it should be cut off and a replacement fitted, following the wiring instructions shown below. The old plug must be disposed of safely, as insertion into a mains socket could cause an electrical hazard



**WARNING! THE WIRES IN THE POWER CABLE SHOULD BE COLOURED IN ACCORDANCE WITH THE FOLLOWING CODE:
Blue = Neutral Brown = Live Yellow and Green = Earth**

To ensure that the colours of the wires in the power cable correspond with the markings on the terminals of your plug, proceed as follows.

- The wire which is coloured **Blue** must be connected to the terminal which is marked **N** or coloured **Black**.
- The wire which is coloured **Brown** must be connected to the terminal which is marked **L** or coloured **Red**.
- The wire which is coloured **Yellow and Green** must be connected to the terminal which is marked **E** or \perp or coloured **Green**

Plug must be BS1363/A approved.

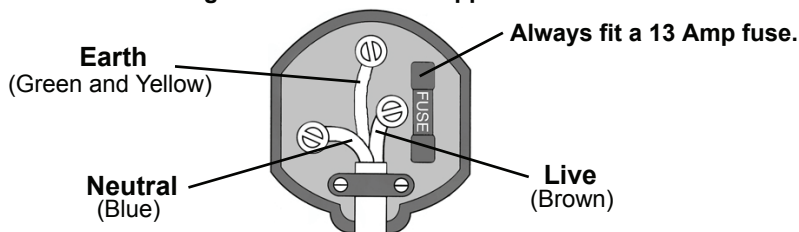

Ensure that the outer sheath of the cable is firmly held by the clamp

We strongly recommend that this machine is connected to the mains supply via a Residual Current Device (RCD)

If in any doubt, consult a qualified electrician. **DO NOT** attempt any connections yourself.

CONTENTS

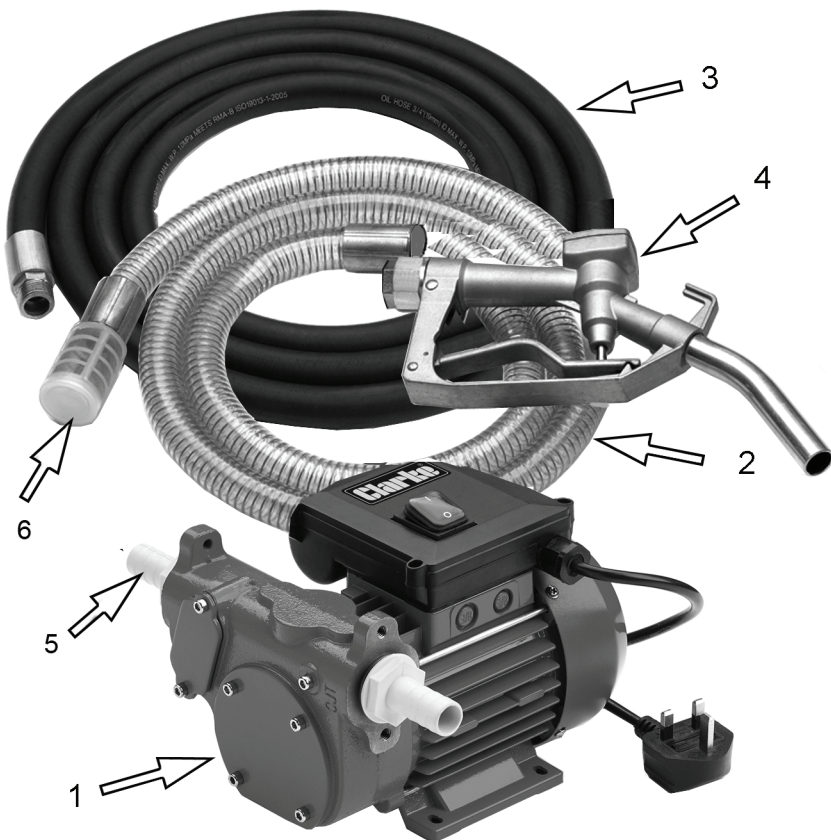

ITEM	DESCRIPTION
1	230 volt fuel transfer pump
2	Transparent Inlet (suction) Hose(1" BSP end fittings)
3	Rubber Outlet (delivery) Hose (1" BSP end fittings)
4	Dispensing Nozzle Assembly
5	1" BSP to 19mm Hose Adaptors
6	Foot Valve/Filter assembly (received attached to suction hose)
7	Hose Clamps (pair)

CONNECTION & OPERATION



WARNING: DO NOT USE WITH PETROL OR ANY OTHER HIGHLY FLAMMABLE LIQUID TO DUE TO THE POSSIBILITY OF SPARKING TAKING PLACE AND CAUSING FIRE.

1. The pump can be installed in any horizontal mounting position and mounted using screws of adequate size (not supplied) through the mounting holes in the base.
2. If the fuel supply tank is located higher than the pump it is advisable to install an anti-siphon valve to prevent the possibility of fuel leaks.
3. The pump should not be installed at more than 6m above the fuel supply.
4. Check the inlet and outlet ports and their threads are clean before connecting the hoses.
5. Before connecting the delivery hose, partially fill the pump body with diesel fuel to facilitate priming. Ensure hoses and tank are free of dirt particles.
6. Screw in either;
 - A) the inlet and outlet hoses supplied or
 - B) the inlet adaptors for use with 19mm hoses

NOTE: The infeed hose is connected to the side of the pump with the inlet filter and the outlet hose to the side marked "OUT" on the pump body.

7. Connect the dispensing nozzle to the outlet hose.
 - The hose and connections need to be completely air tight otherwise air will be drawn in and reduce the flow.
8. Before connecting the delivery hose FOR THE FIRST TIME, partially fill the pump body with fuel to facilitate priming. Ensure the hoses and tank are free from contamination.
9. Ensure the ON/OFF switch is set to the OFF (O) position BEFORE plugging the pump into the power supply.
10. Switch the pump on.
11. When starting for the first time, opening the dispensing nozzle will permit evacuation of air and achieve quicker priming.
12. Always switch off the pump when finished dispensing.
13. Ensure the hose and inlet filter are clean as once clogged, pump performance will quickly decline.
14. When finished pumping, switch off the pump. Do not allow the pump to run dry for more than 30 seconds after discharge has stopped.

FAULTFINDING

Problem	Check	Solution
The pump fails to operate.	Check for power failure if pump is plugged in.	Plug the pump into the socket.
	Check the switch is on and that the fuse is not blown.	Replace fuse or switch on.
	Pump rotor jammed.	Check for possible damage or obstruction of the rotating parts.
	Motor fault.	Return to Clarke Service Department for repair.
	Thermal cut-out has tripped.	Wait for pump to cool down before re-starting.
Motor turns slowly when starting.	Low supply voltage.	Check electrical supply.
Lack of flow delivery.	Low level in the storage tank.	Refill the tank.
	Foot filter blocked.	Clean out the filter.
	Pump is positioned too high above the storage tank.	Position the pump lower in relation to the tank.
	By-pass valve blocked.	Return to Clarke Service Department for repair.
	Air entering the pump via the suction tubing. Narrowing of the suction tubing.	Check the tubing connections. Tubing is damaged, blocked, or the wrong type of tubing being used.
	Low pump speed. Suction tubing is resting on the bottom of the tank.	Check the power supply. Raise the tubing.
Leakage from the pump body.	Seal damaged.	Return to Clarke Service Department for repair.

<p>Increased pump noise</p>	<p>Cavitation of the liquid being pumped.</p> <p>Irregular functioning of the by-pass valve</p> <p>Air present in the diesel fuel.</p>	<p>Reduce suction pressure</p> <p>Dispense fuel until the air is purged from the by-pass system.</p> <p>Check the suction hose connection.</p>
-----------------------------	--	--

MAINTENANCE

The pump requires little maintenance but should be inspected before use to ensure that the power cable is in good condition.

Ensure that the hoses are perfectly sound and secure, and that the filter on the end of the inlet hose is kept clean.

Periodically remove the cover panel shown and clean the pump inlet filter as necessary.

Store the pump in dry conditions protected from the weather.

For any problems requiring dismantling of the pump, contact your CLARKE dealer.

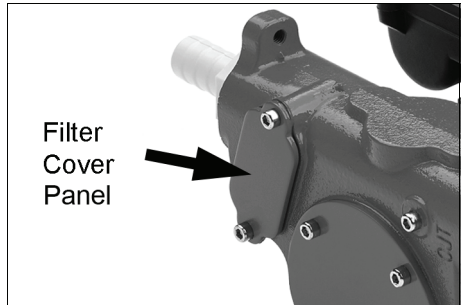

DFT230 COMPONENT PARTS

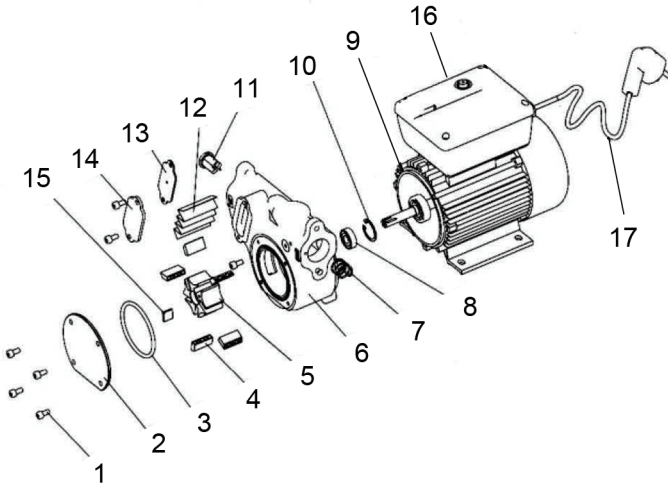

PART NO	DESCRIPTION	PART NO	DESCRIPTION
1	Screw M5 x 10	10	Circlip
2	Front cover	11	By-pass valve
3	O-Ring	12	Filter
4	Rotor blade	13	Rubber gasket
5	Rotor	14	Filter cover
6	Pump body	15	Key
7	By-pass spring	16	Control box
8	Seal	17	Power cable/plug
9	Motor		

DECLARATION OF CONFORMITY



Clarke[®]
INTERNATIONAL

Hemnoll Street, Epping, Essex CM16 4LG

DECLARATION OF CONFORMITY

This is an important document and should be retained.

We hereby declare that this product(s) complies with the following directive(s):

2006/42/EC *Machinery Directive.*
2014/30/EU *Electromagnetic Compatibility Directive.*
2011/65/EU *Restriction of Hazardous substances.*

The following standards have been applied to the product(s):

EN 60335-1:2012+A11:2014, EN 60335-2-41:2003+A1:2004+A2:2010, EN 62233:2008,
EN 61000-6-3:2007+A1:2011, EN 61000-6-1:2007, EN 61000-3-3:2013, EN 60204-1:2006+A1:2009,
EN ISO 12100:2010, EN 809:1998+A1:2009.

The technical documentation required to demonstrate that the product(s) meet(s) the requirement(s) of the aforementioned directive(s) has been compiled and is available for inspection by the relevant enforcement authorities.

The CE mark was first applied in: 2016

Product Description: Diesel Fuel transfer Pump 230v.
Model number(s): DFT230
Serial / batch Number: N/A
Date of Issue: 18/07/2016

Signed:

J.A. Clarke
Director

A SELECTION FROM THE VAST RANGE OF

Clarke®

QUALITY PRODUCTS

AIR COMPRESSORS

From DIY to industrial, Plus air tools, spray guns and accessories.

GENERATORS

Prime duty or emergency standby for business, home and leisure.

POWER WASHERS

Hot and cold, electric and engine driven - we have what you need

WELDERS

Mig, Arc, Tig and Spot. From DIY to auto/industrial.

METALWORKING

Drills, grinders and saws for DIY and professional use.

WOODWORKING

Saws, sanders, lathes, mortisers and dust extraction.

HYDRAULICS

Cranes, body repair kits, transmission jacks for all types of workshop use.

WATER PUMPS

Submersible, electric and engine driven for DIY, agriculture and industry.

POWERTOOLS

Angle grinders, cordless drill sets, saws and sanders.

STARTERS/CHARGERS

All sizes for car and commercial use.



PARTS & SERVICE: 0208 988 7400

E-mail: Parts@clarkeinternational.com or Service@clarkeinternational.com

SALES: UK 01992 565333 or Export 00 44 (0)1992 565335

Clarke® INTERNATIONAL Hemnall Street, Epping, Essex CM16 4LG
www.clarkeinternational.com