

Clarke® PUMP



12&24V DIESEL FUEL TRANSFER PUMPS
MODEL NO: DFT12 & DFT24

PART NO: 7160040 & 7160045

**OPERATION & MAINTENANCE
INSTRUCTIONS**



GC0816

INTRODUCTION

Thank you for purchasing this CLARKE Pump.

The DFT12 & 24 pumps are designed only for use with diesel, paraffin and light fuel oils and can be connected to vehicle batteries of either 12 or 24 Volts respectively. They must not be used with water, petroleum fuels or alcohol, nor if small solids are known to be in suspension.

Before attempting to use this product, please read this manual thoroughly and follow the instructions carefully. In doing so you will ensure the safety of yourself and that of others around you, and you can look forward to your purchase giving you long and satisfactory service.

SPECIFICATIONS

Fluid Classification / Fluids to be used	Clean (light fuel oil, paraffin & diesel)
Rated Max. Head (suction height)	6 m
Rated Max. Flowrate	40 litres/min (diesel)
Max. Operating Temperature	10-70° C
Max Liquid temperature	40° C
Duty Cycle	30 mins on/ 30 mins off
Weight	9.0 kg (complete kit)
Inlet & Outlet Hose Diameter	3/4" BSP nominal
Motor Voltage	12V DC (DFT12) or 24VDC (DFT24)
IP Rating	IP54
Reserve polarity protection	Yes
Sound pressure level	65 db LpA
Suction/Delivery Hose Lengths	2 m
Supply Cable lengths	2 m

Please note that the details and specifications contained herein, are correct at the time of going to print. However, CLARKE International reserve the right to change specifications at any time without prior notice.

SAFETY PRECAUTIONS

Please read all of the safety and operating instructions carefully before using this product. **Keep these instructions in a safe place for future reference.**

WORK AREA

1. **Keep the work area clean and well lit.** Cluttered and dark areas invite accidents.
2. **Do not operate power products in explosive atmospheres such as in the presence of flammable liquids, gasses or dust.** Power products create sparks which may ignite dust or fumes.

ELECTRICAL SAFETY

1. **Do not abuse the electrical cables. Keep the cables away from hot surfaces, oil, sharp edges or moving parts.** Damaged or tangled cables increase the risk of electric shock.

PUMP SAFETY

1. Do not use this pump where there is a danger of fire.
2. Do not use to pump any liquid other than diesel, paraffin and light fuel oil.
3. Always ensure the ON/OFF switch is in the **OFF (O)** position, **BEFORE** connecting to the battery. This is to avoid the possibility of arcing taking place, thereby reducing the risk of fire.
4. Both models incorporate reverse polarity protection in case of incorrect connection.
5. Switch the pump OFF as soon as the task is complete.
6. Do not exceed the duty cycle stated in the specifications.
7. **Do not use the pump if the switch does not turn it on and off.** Any power product that cannot be controlled with the switch is dangerous and must be repaired.
8. If necessary, have your pump repaired by a qualified person using identical replacement parts. This will ensure that the safety of the product is maintained.

ENVIRONMENTAL PROTECTION

1. Take care to ensure that if diesel fuel is spilt that it is cleaned away using sand or treated with absorbent granules designed for the purpose.

2. Always make every effort to contain any spillage and prevent ingress into the local water course.

ENVIRONMENTAL RECYCLING POLICY



Through purchase of this product, the customer is taking on the obligation to deal with the WEEE in accordance with the WEEE regulations in relation to the treatment, recycling & recovery and environmentally sound disposal of the WEEE.

In effect, this means that this product must not be disposed of with general household waste. It must be disposed of according to the laws governing Waste Electrical and Electronic Equipment (WEEE) at a recognised disposal facility.

GUARANTEE

This CLARKE product is guaranteed against faulty manufacture for a period of 12 months from the date of purchase. Please keep your receipt as proof of purchase.

This guarantee is invalid if the product is found to have been abused or tampered with in any way, or not used for the purpose for which it was intended.

Faulty goods should be returned to their place of purchase. No product can be returned to us without prior permission.

This guarantee does not effect your statutory rights.

CONTENTS

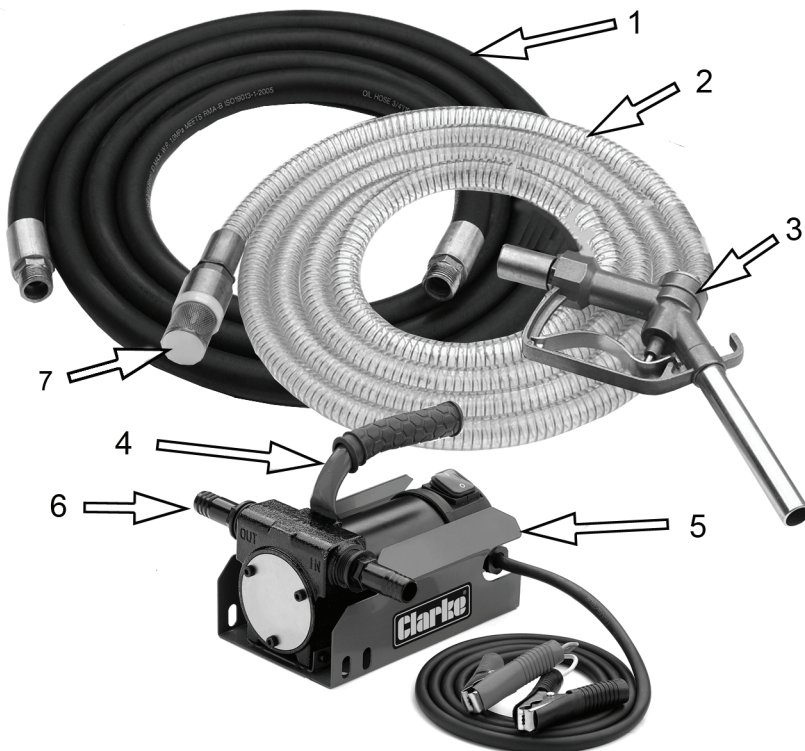

ITEM	DESCRIPTION
1	Rubber Outlet Hose (3/4" male BSP end fittings)
2	Transparent Inlet Hose (3/4" male end fittings)
3	Dispensing Nozzle assembly
4	Carrying Handle c/w fixing screw/washer
5	12V or 24V Pump, c/w power cables & crocodile battery clips
6	3/4" BSP to 19mm Hose Adaptors (with O-rings)
7	Foot Valve/Filter assembly
8	Hose Clamps (pair)

CONNECTION & OPERATION



WARNING: DO NOT USE WITH PETROL OR ANY OTHER HIGHLY FLAMMABLE LIQUID TO DUE TO THE POSSIBILITY OF SPARKING TAKING PLACE AND CAUSING FIRE.

1. Fit the carrying handle to the pump with the hex screw & washer provided.
2. If required, the pump can be installed in any horizontal mounting position and mounted to a flat surface using screws of adequate size (not supplied) through the mounting holes in the base.

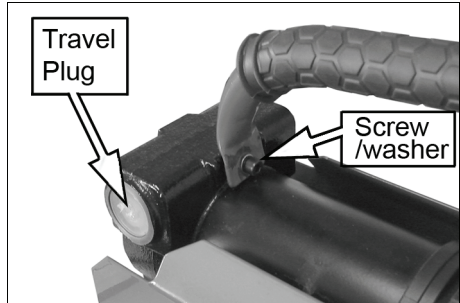

- The pump should not be installed at more than 6m above the fuel supply.
3. Before connecting the pump, remove the travel plugs from the inlet/outlet ports.
 4. If not already fitted, screw the inlet filter to the plastic suction hose.
 5. Screw in either:
 - A) the inlet and outlet hoses supplied or
 - B) the inlet adaptors for use with 19 mm hoses

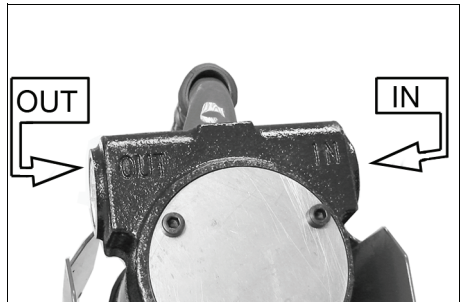

NOTE: The transparent suction hose is connected to the side of the pump marked "IN" and the delivery hose to the side marked "OUT" on the pump casting.

- The hose and connections need to be completely air tight, otherwise air will be drawn in and reduce the flow.
6. Before connecting the delivery hose FOR THE FIRST TIME, partially fill the pump body with fuel to facilitate priming. Ensure the hoses and tank are free from contamination.
 7. Insert the transparent suction hose & filter into the diesel fuel container.

8. Ensure the ON/OFF switch is set to the OFF (O) position BEFORE connecting the pump cables to the vehicle battery.

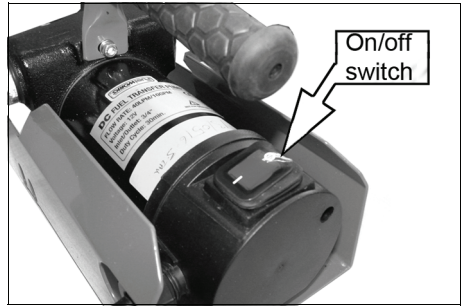

CAUTION: ONLY CONNECT THE DFT12 PUMP TO A 12V BATTERY AND THE DFT24 PUMP TO A 24V BATTERY.

9. Ensure that the battery terminals are clean.
10. Connect the red-positive clamp to the red positive terminal first, then connect the black clamp to the black-negative terminal, ensuring the clamps are perfectly secure.
11. When disconnecting, always disconnect the black (negative) clamp first.
12. Ensure the clamps cannot be disturbed easily and that the setup is protected from passers by.
13. Set the switch to ON (I).
 - Ensure the transparent inlet suction hose and inlet filter clean as once clogged, pump performance will quickly decline.
 - Do not allow the pump to run dry for more than 30 seconds after pumping has stopped. When finished pumping, switch off the pump.
14. During start-up it may be beneficial to open the dispensing nozzle on the delivery hose to permit evacuation of air and achieve quicker priming.

FAULTFINDING

Problem	Check	Solution
Pump fails to operate.	Check for good contact between crocodile clips and battery.	Establish good contact.
	Check the switch is on and that the fuse is not blown.	Replace fuse or switch on.
	Pump rotor jammed.	Check for possible damage or obstruction of the rotating parts.
	Motor fault.	Return to Clarke Service Department for repair.
Motor turns slowly when starting.	Low supply voltage.	Check condition of battery.
Lack of flow delivery.	Low level in the storage tank.	Refill the tank.
	Foot filter blocked.	Clean out the filter.
	Pump is positioned too high above the storage tank.	Position the pump lower in relation to the tank.
	By-pass valve blocked.	Return to Clarke Service Department for repair.
	Air entering the pump via the suction hose. Narrowing of the suction hose.	Check the security of hose connections. Hose is damaged, blocked.
	Low pump speed. Suction tubing is resting on the bottom of the tank.	Check the power supply. Raise the tubing.
Leakage from the pump body.	Seal damaged.	Return to Clarke Service Department for repair.

Increased pump noise	Cavitation of the liquid being pumped.	Reduce suction pressure
	Irregular functioning of the by-pass.	Dispense fuel until the air is purged from the by-pass system.
	Air present in the diesel fuel.	Check the suction hose connection.

MAINTENANCE

The pump does not require any maintenance but should be inspected before use to ensure that the power cables and clamps are in good condition and that both of the hoses are sound.

Avoid using solvents if cleaning plastic parts, as most plastics are susceptible to damage from various types of commercial solvents. Keep the filter on the inlet hose free of accumulated dirt.

Store the pump in dry conditions protected from the weather.

For any problems requiring dismantling of the pump, contact your CLARKE dealer.

DFT12/24 COMPONENT PARTS

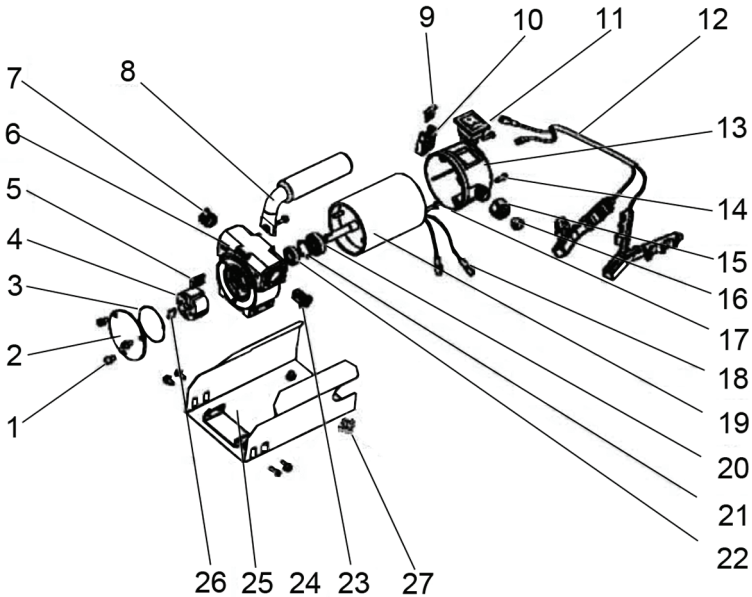

PART NO	DESCRIPTION	PART NO	DESCRIPTION
1	Screw M5 x 10	15	Locknut
2	Front Cover	16	Tapered Bush
3	O-Ring	17	Nut M5
4	Rotor	18	Cable
5	Blade	19	Motor 12V/24V
6	Pump Body	20	Bearing
7	By-pass Spring	21	Spring Collar
8	Handle	22	Seal
9	Fuse 15A/25A	23	By-pass Valve
10	Fuse Holder	24	Screw M5 x 10
11	Single Pole Switch	25	Base
12	Cable c/w Crocodile Clip	26	Key
13	Junction Box	27	Bridge Rectifier
14	Screw M4 x 15		

DECLARATION OF CONFORMITY



Hemmill Street, Epping, Essex CM16 4LG

DECLARATION OF CONFORMITY

This is an important document and should be retained.

We hereby declare that this product(s) complies with the following directive(s):

- 2006/42/EC Machinery Directive.
- 2014/30/EU Electromagnetic Compatibility Directive.
- 2017/65/EU Restriction of Hazardous substances.

The following standards have been applied to the product(s):

- EN 61000-6-3:2007+A1:2011, EN 61000-6-1:2007, EN 61000-6-1:2007, EN 60204-1:2006+A1:2009, EN 60335-1:2012+A11:2014, EN 60335-2-41:2003+A1:2004+A2:2010, EN 62233:2008, EN ISO 12100:2010, EN 809:1998+A1:2009

The technical documentation required to demonstrate that this product(s) meet(s) the requirement(s) of the aforementioned directive(s) has been compiled and is available for inspection by the relevant enforcement authorities.

The CE mark was first applied in: 2016

Product Description: Diesel fuel transfer pump 24V.
Model number(s): DFT24.
Serial / batch Number: N/A
Date of Issue: 18/07/2016.

Signed:

J.A. Clarke
Director

DFT24 15-0089 D.O.C (v0)

Page 1 of 1



Hemmill Street, Epping, Essex CM16 4LG

DECLARATION OF CONFORMITY

This is an important document and should be retained.

We hereby declare that this product(s) complies with the following directive(s):

- 2006/42/EC Machinery Directive.
- 2014/30/EU Electromagnetic Compatibility Directive.
- 2017/65/EU Restriction of Hazardous substances.

The following standards have been applied to the product(s):

- EN 60335-1:2012+A11:2014, EN 60335-2-41:2003+A1:2004+A2:2010, EN 62233:2008, EN 61000-6-3:2007+A1:2011, EN 61000-6-1:2007, EN 60204-1:2006+A1:2009, EN ISO 12100:2010, EN 809:1998+A1:2009

The technical documentation required to demonstrate that the product(s) meet(s) the requirement(s) of the aforementioned directive(s) has been compiled and is available for inspection by the relevant enforcement authorities.

The CE mark was first applied in: 2016

Product Description: Diesel fuel transfer pump 12V
Model number(s): DFT12.
Serial / batch Number: N/A
Date of Issue: 18/07/2016.

Signed:

J.A. Clarke
Director

DFT12 15-0079 D.O.C (v0)doc

Page 1 of 1

A SELECTION FROM THE VAST RANGE OF

Clarke®

QUALITY PRODUCTS

AIR COMPRESSORS

From DIY to industrial, Plus air tools, spray guns and accessories.

GENERATORS

Prime duty or emergency standby for business, home and leisure.

POWER WASHERS

Hot and cold, electric and engine driven - we have what you need

WELDERS

Mig, Arc, Tig and Spot. From DIY to industrial.

METALWORKING

Drills, grinders and saws for DIY and professional use.

WOODWORKING

Saws, sanders, lathes, mortisers and dust extraction.

HYDRAULICS

Cranes, body repair kits, transmission jacks for all types of workshop use.

WATER PUMPS

Submersible, electric and engine driven for DIY, agriculture and industry.

POWERTOOLS

Angle grinders, cordless drill sets, saws and sanders.

STARTERS/CHARGERS

All sizes for car and commercial use.

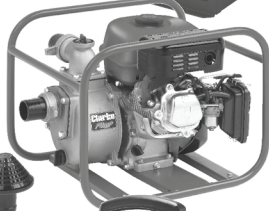

PARTS & SERVICE: 0208 988 7400
E-mail: Parts@clarkeinternational.com or Service@clarkeinternational.com
SALES: UK 01992 565333 or Export 00 44 (0)1992 565335

Clarke® INTERNATIONAL Hemnall Street, Epping, Essex CM16 4LG
www.clarkeinternational.com