

CLAMPBRO®



5-SHELF BOLTLESS SHELVING UNITS

MODEL NO: CSR5265

PART NO: SEE TABLE PAGE 2

ASSEMBLY INSTRUCTIONS



GC0915

INTRODUCTION

Thank you for purchasing this CLARKE Shelving Unit.

Before attempting to use this product, please read this manual thoroughly and follow the instructions carefully. In doing so you will ensure the safety of yourself and that of others around you, and you can look forward to your purchase giving you long and satisfactory service.

GUARANTEE

This product is guaranteed against faulty manufacture for a period of 12 months from the date of purchase. Please keep your receipt which will be required as proof of purchase.

This guarantee is invalid if the product is found to have been abused or tampered with in any way, or not used for the purpose for which it was intended.

Faulty goods should be returned to their place of purchase, no product can be returned to us without prior permission.

This guarantee does not effect your statutory rights.

SCOPE

These instructions cover the following models

Description	Model	Part Number
5-Shelf 265kg Boltless Shelving (Light Grey)	CSL5265/30LG	6600716
5-Shelf 265kg Boltless Shelving (Light Grey)	CSL5265/60LG	6600718
5-Shelf 265kg Boltless Shelving (Light Grey)	CSL5265/40LG	6600720

INVENTORY

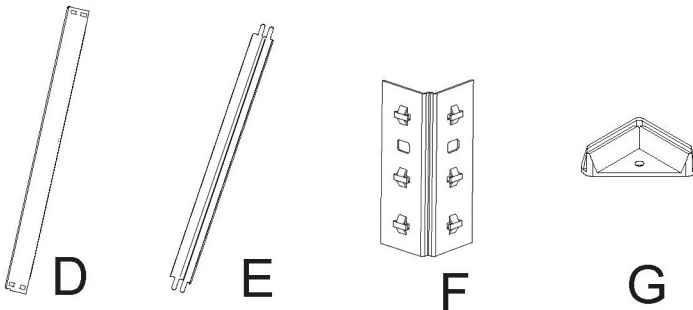
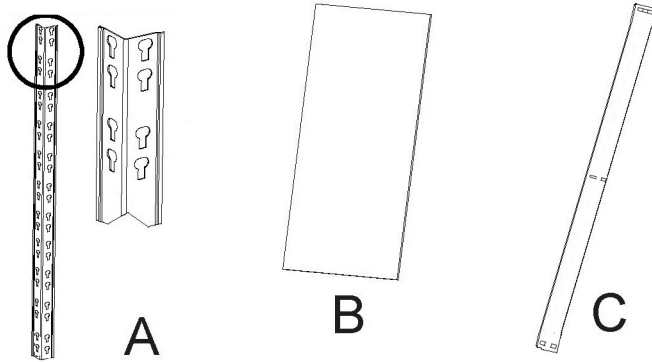

No	Description	Quantity
A	Corner Post	8
B	Shelf	5
C	Long Beam	10
D	Short Beam	10
E	Centre Beam	5
F	Post Joining Insert	4
G	Plastic End Cap	8

ASSEMBLY ADVICE

1. Assemble on a strong, level surface. Avoid assembly on a domestic carpet.
2. Use a cloth or softwood block to protect the surface finish of the product when using a mallet. Strike the flat surface of each beam to prevent damage to the beam.
3. Always ensure that the rivets sit at the bottom of the keyhole slots.
4. It is recommended that the assembly should be done by two persons.
5. Always wear protective gloves when assembling this shelving.
6. The shelving unit is not recommended for outdoor use.

ASSEMBLY INSTRUCTIONS

TOOLS REQUIRED

- Rubber mallet or hammer
- Protective cloth/wood block

ASSEMBLY

The tabs of the beams will often enter the slots fully using just firm hand pressure but if they are too tight, you may require a rubber mallet to assist. If so, always use a cloth to protect the product paint finish.

Tap gently with the mallet to drive the tabs of the beams fully into the slots in the corner post. Always strike the edge close to the post.

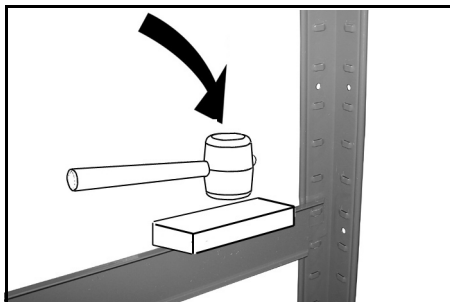

1. Use the short beams (D) to connect the front and rear posts together.

NOTE: The edge with the wider flange should be installed uppermost to support the shelf.

- Repeat this again to create the other end assembly, making sure that the corresponding beams are at the same height.
2. Ensure the posts are the right way up with the upper ends as shown in the detail.

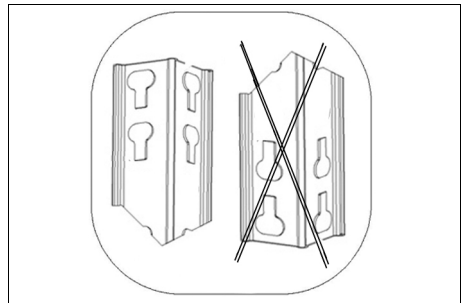
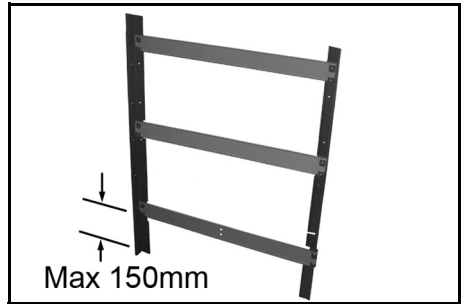

3. Join the two end assemblies together with the long beams (C) as shown.



4. Connect the support beams (E) to the long beams (C) by bending the flexible tabs to 90 degrees and slotting them into place as shown. Finally bend the tabs back 180 degrees to lock in place.

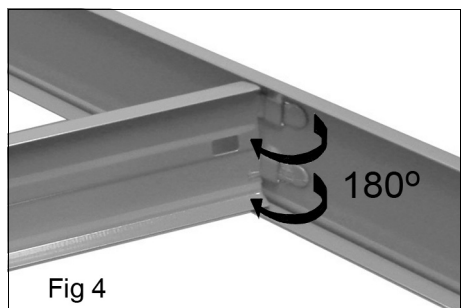

5. Fit post joining inserts (F) into the posts (A), ensuring that the inserts are fitted with their keyholes to match those of the posts.
6. Construct the upper end assemblies onto the post inserts (F) before adding more long beams and support beams as previously to complete the framework.

NOTE: Remember that the top shelf should be fitted at the highest possible position.

7. Lay the shelf panels (B) into position..

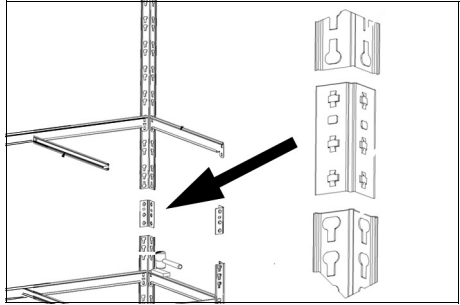

8. Insert the plastic end caps (G) into the end of each post (A).



We recommend that the shelving be secured to an adjacent wall using typical wall insert plugs and screws (not supplied) aligned with the assembly slots in the posts.

GENERAL SAFETY RULES

1. Always maintain equipment in good condition for the best/safest performance.
2. Never exceed the maximum load for these shelving units as stated in the specification.
3. Never use these units if they are damaged.
4. Always load small, stable items on the top shelves, heavier and bulky items should be stored on the lower shelves.
5. Always distribute heavy loads evenly across the shelves.

Please keep these instructions in a safe place for future reference.

SPECIFICATIONS

Model	Dimensions (W x D x H)	Weight (Empty)	Load per shelf (evenly distributed)
CSR5175/30 Units	900 x 300 x 1800 mm	14.8 kg	175 kg
CSR5175/45 Units	900 x 450 x 1800 mm	19 kg	175 kg
CSR5175/60 Units	900 x 600 x 1800 mm	23.5 kg	175 kg

ENVIRONMENTAL PROTECTION

Do not dispose of old products or damaged parts with general household waste. All tools, accessories and packaging no longer required should be sorted, taken to a recycling centre and disposed of appropriately.

A SELECTION FROM THE VAST RANGE OF

Clarke®

QUALITY PRODUCTS

AIR COMPRESSORS

From DIY to industrial, Plus air tools, spray guns and accessories.

GENERATORS

Prime duty or emergency standby for business, home and leisure.

POWER WASHERS

Hot and cold, electric and engine driven - we have what you need

WELDERS

Mig, Arc, Tig and Spot. From DIY to auto/industrial.

METALWORKING

Drills, grinders and saws for DIY and professional use.

WOODWORKING

Saws, sanders, lathes, mortisers and dust extraction.

HYDRAULICS

Cranes, body repair kits, transmission jacks for all types of workshop use.

WATER PUMPS

Submersible, electric and engine driven for DIY, agriculture and industry.

POWER TOOLS

Angle grinders, cordless drill sets, saws and sanders.

STARTERS/CHARGERS

All sizes for car and commercial use.



PARTS & SERVICE: 0208 988 7400

E-mail: Parts@clarkeinternational.com or Service@clarkeinternational.com

SALES: UK 01992 565333 or Export 00 44 (0)1992 565335

Clarke® INTERNATIONAL Hemnall Street, Epping, Essex CM16 4LG
www.clarkeinternational.com