

Clarke®



INDUSTRIAL SHELVING

Model Nos:CS4700 & CS4700BO

Part Nos:6600502 & 6600610

ASSEMBLY INSTRUCTIONS

INTRODUCTION

Thank you for purchasing this CLARKE Shelving Unit.

Before attempting to use the product, it is essential that you read this manual thoroughly and carefully follow all instructions given. In doing so you will ensure the safety of yourself and that of others around you, and you can also look forward to the product giving you long and satisfactory service.

GUARANTEE

This product is guaranteed against faulty manufacture for a period of 12 months from the date of purchase. Please keep your receipt which will be required as proof of purchase.

This guarantee is invalid if the product is found to have been abused or tampered with in any way, or not used for the purpose for which it was intended.

Faulty goods should be returned to their place of purchase, no product can be returned to us without prior permission.

This guarantee does not effect your statutory rights.

ENVIRONMENTAL PROTECTION



Do not dispose of this product with general household waste. All tools, accessories and packaging should be sorted, taken to a recycling centre and disposed of appropriately.

PARTS & SERVICING

For parts & Servicing, please contact your nearest dealer, or CLARKE International, on one of the following numbers.

PARTS & SERVICE TEL: 020 8988 7400

PARTS & SERVICE FAX: 020 8558 3622

or e-mail as follows:

PARTS: Parts@clarkeinternational.com

SERVICE: Service@clarkeinternational.com

TECHNICAL SPECIFICATION

Models CS4700/CS4700BO

Dimensions (W x D x H)	1940 x 610 x 1830 mm
Product Weight	112kg
Load per shelf	800kg (evenly distributed)

Please note that the details and specifications contained herein, are correct at the time of going to print. However, CLARKE International reserve the right to change specifications at any time without prior notice.

LIST OF COMPONENTS

When unpacking, check for damage and/or shortages etc. Any found should be reported to your CLARKE dealer where the product was originally purchased. This shelving unit should include the following:

- 2 x Upright Frames
- 8 x Beams
- 16 x Deck Supports
- 4 x Deck Panels
- 1 x Instruction Manual (this document)

TOOLS REQUIRED

- Rubber mallet or hammer.
- Protective cloth/wood block.

GENERAL SAFETY RULES

1. **ALWAYS** maintain the shelving in good condition for greater safety.
2. **NEVER** exceed the maximum load for this product.
3. **NEVER** use this product if damaged.
4. **ALWAYS** load small, stable items on the top shelves, heavier and bulky items should be stored on the lower shelves.

Please keep these instructions in a safe place for future reference.

COMPONENT PARTS

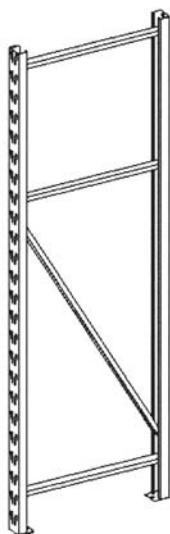

A-Upright Frame (2)

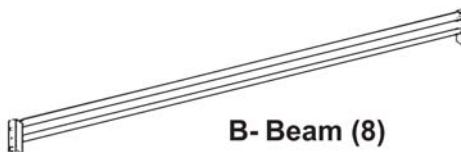

B- Beam (8)

C-Deck Supports (16)

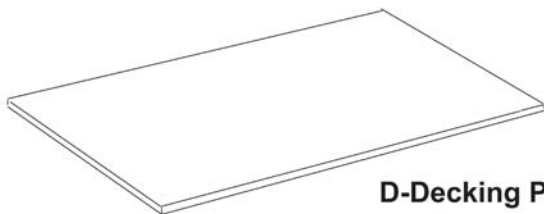

D-Decking Panel (4)

ASSEMBLY TIPS

1. Assemble the unit on a strong, level surface. Avoid assembly on soft surfaces.
 2. Use a cloth or softwood block to protect the surface finish of the product when using a hammer. Hit the flat surface of each cross-beam to prevent damage to the beam.
 3. Always ensure that the tabs sit at the bottom of the tapered slots.
 4. It is recommended that the assembly should be done by two persons.
 5. This product is not recommended for outdoor use.
-

ASSEMBLY INSTRUCTIONS

1. Take a beam (B) and attach to one of the upright frames by inserting the two clips on the bracket into the keyholes of the frame column. Present them from the outside.
2. Drive the tabs right to the bottom of the slots by tapping the beam near the joint with a rubber mallet to lock the pieces together as shown in Fig 1.

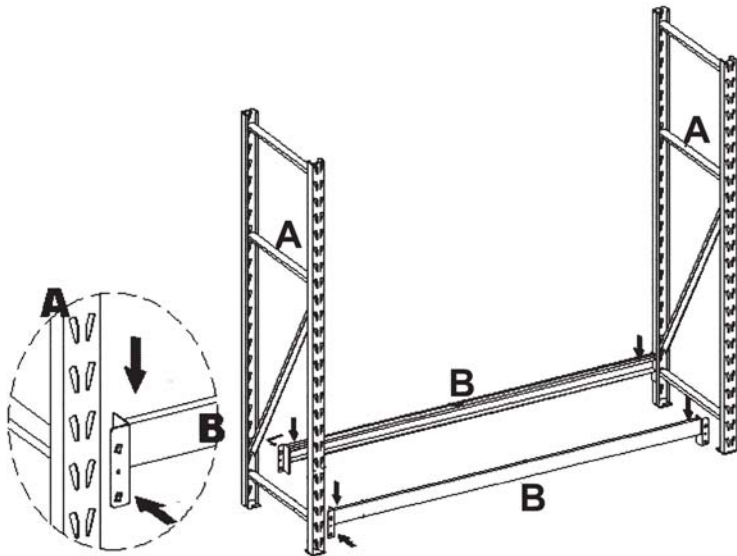

Fig 1

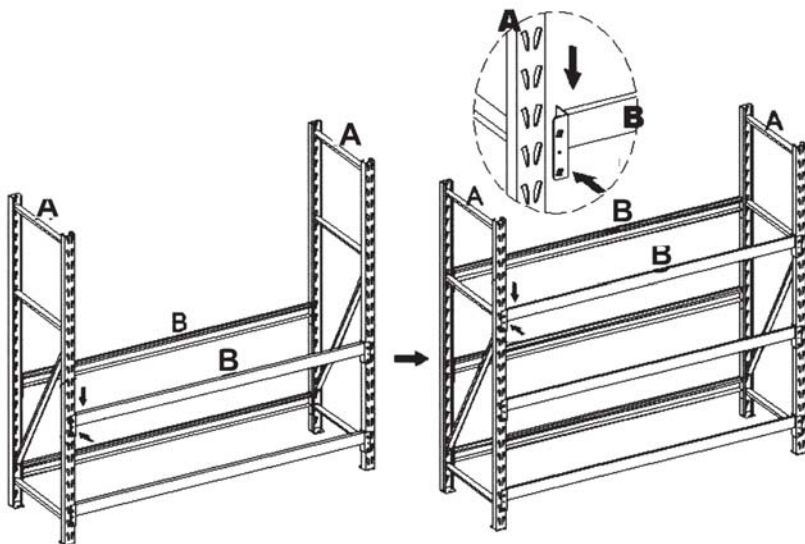

Fig 2

3. Repeat this step with the second upright frame (A) at the other end of the beam, making sure that the clips are at the same level.
4. Repeat with the other beam (B), making sure that the beams are level.

NOTE: Take care not to strike so hard as to damage the beams.

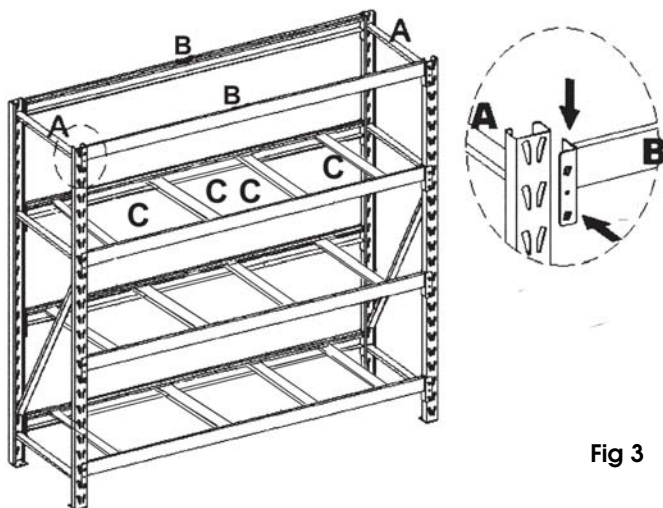

Fig 3

- Repeat steps 2 to 4 to attach the next set of beams (B) at the same level to form the second and third shelf frames as shown in fig 2.

NOTE: The units are adjustable in 3" increments.

- Ensure the last two beams (B) are set into the top two keyholes of the upright frames as shown in Fig 3.
- Position the deck supports (C) to span between the beams (B), engaging the support end in the socket provided in the beam. Four supports per shelf are required at the positions shown.
- Place the deck panels (D) onto the deck supports, resting on the top flange of the beams. Make sure the deck panels sit properly between the beams and lay flush as shown in Fig 4.

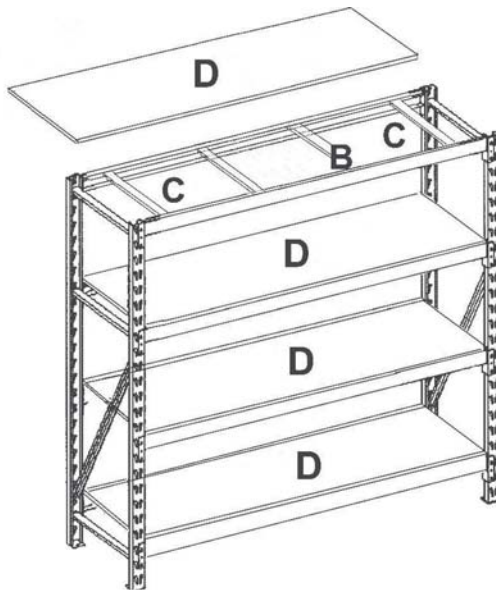

Fig 4

- Periodically inspect the unit to ensure the beams are seated correctly and are firmly connected to the columns. Take care not to overload the shelves.

A SELECTION FROM THE VAST RANGE OF

Clarke®

QUALITY PRODUCTS

AIR COMPRESSORS

From DIY to industrial, Plus air tools, spray guns and accessories.

GENERATORS

Prime duty or emergency standby for business, home and leisure.

POWER WASHERS

Hot and cold, electric and engine driven - we have what you need

WELDERS

Mig, Arc, Tig and Spot.

From DIY to auto/industrial.

METALWORKING

Drills, grinders and saws for DIY and professional use.

WOODWORKING

Saws, sanders, lathes, mortisers and dust extraction.

HYDRAULICS

Cranes, body repair kits, transmission jacks for all types of workshop use.

WATER PUMPS

Submersible, electric and engine driven for DIY, agriculture and industry.

POWER TOOLS

Angle grinders, cordless drill sets, saws and sanders.

STARTERS/CHARGERS

All sizes for car and commercial use.

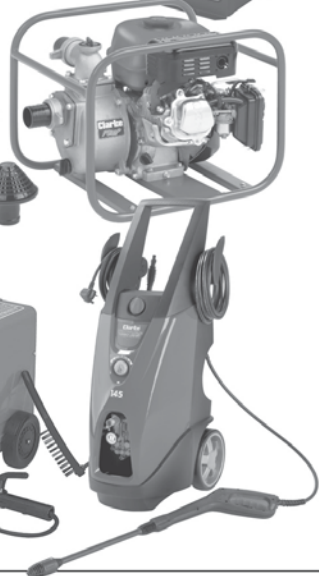

PARTS & SERVICE: 020 8988 7400

E-mail: Parts@clarkeinternational.com or Service@clarkeinternational.com

SALES: UK 01992 565333 or Export 00 44 (0)1992 565335

Clarke INTERNATIONAL Hemnall Street, Epping, Essex CM16 4LG
www.clarkeinternational.com