

# Clarke®

## WOODWORKER



### BELT & DISC SANDER

MODEL NO: CS4-6E

PART NO: 6500413

### OPERATION & MAINTENANCE INSTRUCTIONS



ORIGINAL INSTRUCTIONS

GC0321 rev 2

---

## INTRODUCTION

---

Thank you for purchasing this CLARKE product.

Before attempting to use this product, please read this manual thoroughly and follow the instructions carefully. In doing so you will ensure the safety of yourself and that of others around you, and you can look forward to your purchase giving you long and satisfactory service.

---

## GUARANTEE

---

This product is guaranteed against faulty manufacture for a period of 12 months from the date of purchase. Please keep your receipt which will be required as proof of purchase.

This guarantee is invalid if the product is found to have been abused or tampered with in any way, or not used for the purpose for which it was intended.

Faulty goods should be returned to their place of purchase, no product can be returned to us without prior permission.

This guarantee does not effect your statutory rights.

---

## INVENTORY

---

The following should be supplied. If any items are missing, please contact your local Clarke dealer.

- 1 x Belt/Disc Sander
- 1 x Sanding Table
- 1 x Tilting Work Table (Fitted)
- 1 x Lower Disc Guard
- 1 x Mitre Guide Assembly
- 1 x 6 mm Hexagon Key
- 1 x Sanding Belt
- 1 x Sanding Disc
- 1 x Fixings Pack

---

## GENERAL SAFETY RULES

---

1. **ALWAYS** learn the machines applications, limitations and the specific potential hazards. Read and become familiar with the entire operating manual.
1. **ALWAYS** use a face or dust mask if the operation is particularly dusty.
2. **ALWAYS** check for damage before using the machine, check for alignment of moving parts, breakage of parts, and any other condition that may affect the machines operation. Damage should be properly repaired or the part replaced. If in doubt, **DO NOT** use the machine. Consult your local dealer.
3. **ALWAYS** disconnect the machine from the power supply before servicing and when changing accessories.
4. **ALWAYS** wear safety goggles, manufactured to the latest European Safety Standards. Everyday eyeglasses do not have impact resistant lenses, and are not safety glasses.
5. **ALWAYS** keep work area clean. Cluttered areas and benches invite accidents.
6. **ALWAYS** ensure that adequate lighting is available. Ensure that lighting is placed so that you will not be working in your own shadow.
7. **ALWAYS** keep children away. All visitors should be kept a safe distance from the work area, especially when the machine is being used.
8. **ALWAYS** maintain machine in top condition. Keep tools/machines clean for the best and safest performance. Follow maintenance instructions.
9. **ALWAYS** handle with extreme care and do not carry the tool/machine by its electric cable, or pull on the cable to disconnect it from the power supply.
10. **ALWAYS** ensure the switch is off before plugging in to mains. Avoid accidental starting.
11. **ALWAYS** concentrate on the job in hand, no matter how trivial it may seem. Be aware that accidents are caused by carelessness due to familiarity.
12. **ALWAYS** keep your proper footing and balance at all times - don't overreach. For best footing, wear rubber soled footwear. Keep floor clear of oil, scrap wood, etc.
13. **ALWAYS** dress properly. Loose clothing or jewellery may get caught in moving parts. Wear protective hair covering to contain long hair.
14. **ALWAYS** guard against electric shock. Avoid contact with earthed surfaces - pipes, radiators etc.

15. **NEVER** operate machine while under the influence of drugs, alcohol or any medication.
16. **NEVER** leave machine running unattended. Turn power off. Do not leave the machine until it comes to a complete stop.
17. **NEVER** force the machine, it will do a better and safer job at the rate for which it was designed.
18. **NEVER** use power tools in damp or wet locations or expose them to rain. Do not use in an explosive atmosphere (around paint, flammable liquids etc.) Avoid dangerous environments.
19. If the tool begins to make an abnormal noise, or produce excessive vibrations, smoke or burning odour, turn the tool off immediately and do not operate until repaired.

---

## EXTRA PRECAUTIONS FOR BELT/DISC SANDERS

---

1. **ALWAYS** wear ear protectors/defenders when using this machine.
2. **ALWAYS** wear a dust mask when using this machine. Be aware that harmful or toxic dust could be produced when sanding some woods.
3. **ALWAYS** use the table to support the workpiece.
4. **ALWAYS** check to ensure the table and attachments are secure before starting.
5. **ALWAYS** maintain a clearance of 2-3mm between table and sanding disc.
6. **ALWAYS** hold the workpiece firmly so that it cannot be torn from your hands.
7. **ALWAYS** feed the workpiece against the direction of rotation of the disc. i.e the LEFT side of the disc.
8. **ALWAYS** keep the mains cable well away from the machine and ensure an adequate electrical supply is close at hand so that the operation is not restricted by the length of the cable.
9. **ALWAYS** use a dust extraction device, properly connected to the dust extraction port.
10. **ALWAYS** ensure that nails or foreign objects have been removed from a workpiece beforehand. Nails etc. will destroy the belt or disc.
11. **NEVER** allow the ventilation slots in the motor to become blocked.
12. **NEVER** sand pieces which cannot be held firmly by hand.

## ELECTRICAL CONNECTIONS



**WARNING: READ THESE ELECTRICAL SAFETY INSTRUCTIONS THOROUGHLY BEFORE CONNECTING THE PRODUCT TO THE MAINS SUPPLY.**

Before switching the product on, make sure that the voltage of your electricity supply is the same as that indicated on the rating plate. This product is designed to operate on 230VAC 50Hz. Connecting it to any other power source may cause damage.

This product may be fitted with a non-rewireable plug. If it is necessary to change the fuse in the plug, the fuse cover must be refitted. If the fuse cover becomes lost or damaged, the plug must not be used until a suitable replacement is obtained.

If the plug has to be changed, it should be cut off and a replacement fitted, following the wiring instructions shown below. The old plug must be disposed of safely, as insertion into a mains socket could cause an electrical hazard.



**WARNING: THE WIRES IN THE POWER CABLE OF THIS PRODUCT ARE COLOURED IN ACCORDANCE WITH THE FOLLOWING CODE:  
BLUE = NEUTRAL    BROWN = LIVE    YELLOW AND GREEN = EARTH**

If the colours of the wires in the power cable of this product do not correspond with the markings on the terminals of your plug, proceed as follows.

- The **blue** wire must be connected to the terminal marked **N** or coloured **Black**.
- The **Brown** wire must be connected to the terminal marked **L** or coloured **Red**.
- The **Yellow and Green** wire must be connected to the terminal marked **E** or  $\perp$  or coloured **Green**.

**Plug must be BS1363/A approved.**

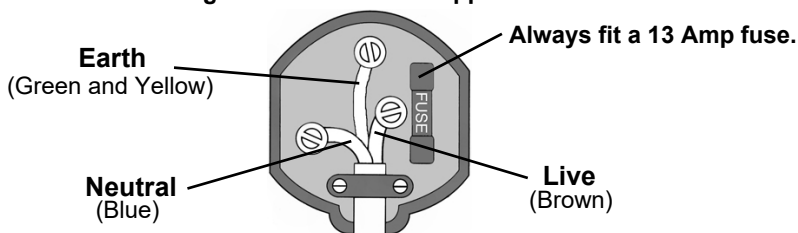

**Ensure that the outer sheath of the cable is firmly held by the clamp**

We strongly recommend that this machine is connected to the mains supply via a Residual Current Device (RCD)

If in any doubt, consult a qualified electrician. DO NOT attempt any repairs yourself.

## OVERVIEW

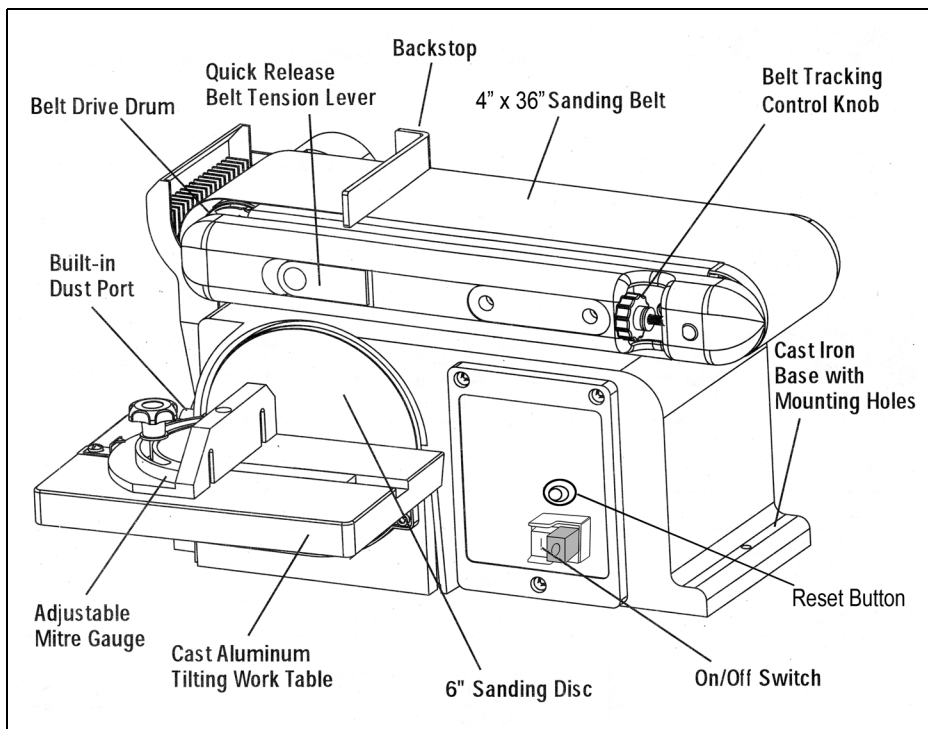

Sanding work is inherently dusty. It is strongly recommended that users use a dust-collection system when using this belt & disc sander. The use of a mask or respirator is still recommended even when a dust-collection system is in use.

## ASSEMBLY



CAUTION: THE SANDER MUST BE ASSEMBLED BEFORE USE. DO NOT PLUG THE SANDER INTO A POWER SOURCE UNTIL IT HAS BEEN COMPLETELY ASSEMBLED.

### MOUNTING THE SANDER TO A WORKBENCH

Before attempting to use this sander, it should be properly mounted to a workbench or stand

1. Position the sander on the workbench where you intend to use it.
2. Mark the workbench through the mounting holes located in the sander base. Drill holes in the workbench at the marks.
3. Use long bolts, spring washers and nuts (not supplied), to secure the sander to the workbench as shown.

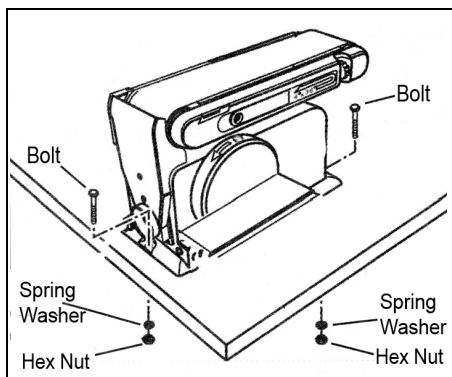

### MOUNTING THE TILTING WORK TABLE ASSEMBLY

1. Position the table-support bracket so that the "pivot pin" fits into the corresponding hole on the sander frame and the radius slot aligns with the threaded hole in the frame.
2. Place a washer on the threaded shaft of the knob, insert through radius slot, and tighten into threaded hole.
3. Adjust the table to the angle desired for the sanding task.
4. To avoid trapping the workpiece or your fingers between the table and disc, adjust the position of the table on its mounting bracket to maintain a gap of no more than 2 mm.

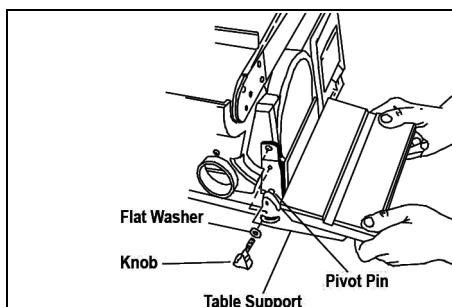

## INSTALLING THE BACKSTOP

1. Position the backstop against the frame so that the slot aligns with threaded hole in the frame.
2. Secure the backstop to the frame with 2 x socket head screws and washers as shown.
  - Do not overtighten.
  - The gap between the sanding belt and the backstop should be no more than 2 mm.

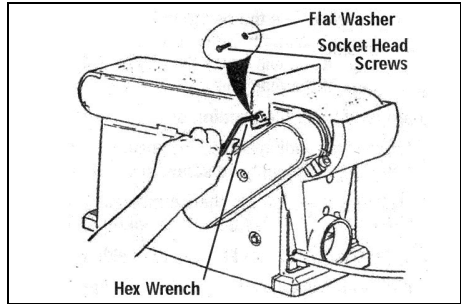

## ATTACHING A DUST COLLECTION HOSE

This sander is equipped with a 2½" (60 mm) diameter dust port that can be connected to a vacuum or dust-collection system.

1. Place a 2½" ID diameter hose over the dust port.

Secure the hose in place with a hose clamp.

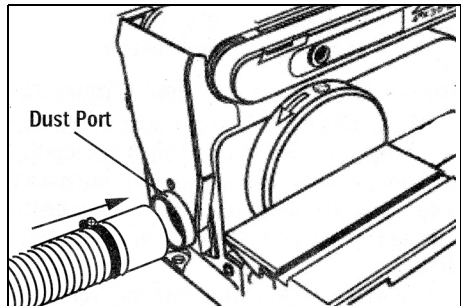



## CHANGING THE SANDING DISCS



**WARNING: TURN THE POWER OFF AND REMOVE THE PLUG FROM THE POWER OUTLET BEFORE CHANGING THE ACCESSORIES.**



**CAUTION: 'HOOK & LOOP' SANDING DISCS CANNOT BE USED WITH THIS SANDER!**

1. Remove the mitre gauge and work table assembly.
2. Remove the disc guard screws and disc guard.
3. Remove the sanding disc from the disc plate.
  - Sanding discs are attached to the plate using a pressure-sensitive adhesive
4. Ensure the disc plate is clean.
5. Peel the backing away from the new sanding disc.
6. Align perimeter of the disc with the plate and press the disc firmly into position on the plate, leaving no loose edges.
7. Replace the disc guard, disc guard screws and work table.

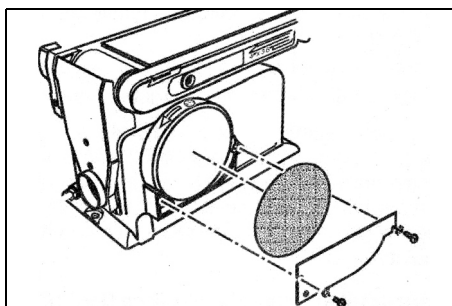
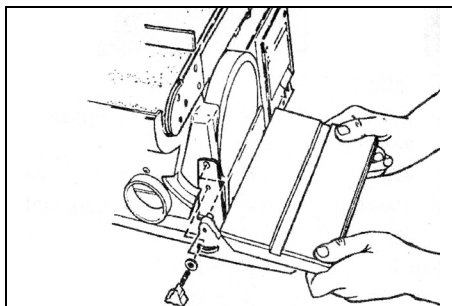

## CONSUMABLES

Sanding discs are available from your Clarke dealer.

| Grit   | Part number |
|--------|-------------|
| Fine   | 6502097     |
| Medium | 6500809     |
| Coarse | 6502102     |

## CHANGING THE SANDING BELTS



CAUTION: CHECK THE INSIDE OF THE BELT FOR A "DIRECTION ARROW". IF PRESENT, INSTALL THE BELT WITH THE ARROW POINTING IN THE SAME DIRECTION AS THE DIRECTION INDICATOR ON THE HOUSING.

1. Loosen the socket head screw using the 6 mm hex wrench provided.
2. Raise the belt sanding arm as shown.
3. Slide out one end of the tension lever as shown to release belt tension.
4. Remove the tray located on the bottom of the belt sanding arm by loosening the two screws on the back of the belt sanding arm.

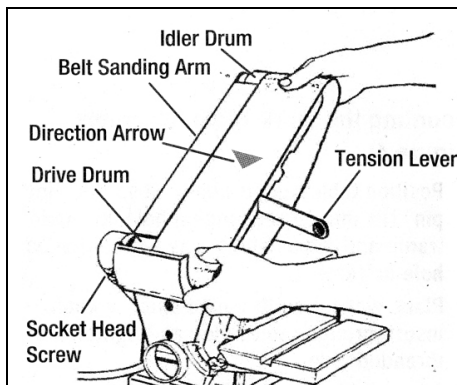

5. Slide the sanding belt off of the drive and idler drums.
6. Slide new sanding belt over the drive and idler drums. Ensure the belt is centred on both drums and is the right way round.
7. Return the tension lever into its original position to apply tension to the belt.
8. Replace the tray and tighten the two screws on the back of the belt sanding arm.
9. Lower the belt sanding arm and tighten the socket head screw using the 6 mm hex wrench provided.

### CONSUMABLES

Sanding Belts are available from your Clarke dealer.

| Grit   | Part number |
|--------|-------------|
| Fine   | 6502096     |
| Medium | 6500808     |
| Coarse | 6502101     |

10. Before using, check belt tracking as described in the next section and adjust as necessary.

## BELT TRACKING

The belt-tracking adjustment is set at the factory so that the abrasive belt will run true on the drums. If, however, the belt should track to one side or the other, an adjustment can be made by turning the tracking knob.

- Turning the knob clockwise will cause the belt to track to the right (towards the disc sander).
- Turning the knob counter-clockwise will cause the belt to track to the left side of the machine.

## TO TRACK THE SANDING BELT

1. Rotate the sanding arm to the desired position and tighten socket head screw to secure.
2. Turn power switch ON,
3. Note whether the belt tends to wander off its track, and to which side (left or right) of the sander.
  - If the sanding belt does not move to either side, it is tracking properly.
  - If the sanding belt moves to the right (disc side of the sander), turn the tracking knob counter clockwise  $\frac{1}{4}$  turn.
  - If the sanding belt moves to the left (away from the disc), turn the tracking knob clockwise  $\frac{1}{4}$  turn.
4. Readjust tracking knob another  $\frac{1}{4}$  turn, as necessary.

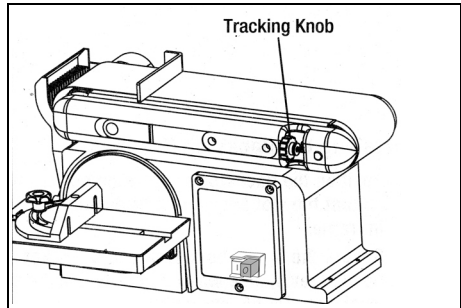

# OPERATION



**WARNING: NEVER TOUCH THE SANDING DISC OR BELT WHILE IT IS MOVING, DO NOT TOUCH THE WORK PIECE AFTER SANDING, IT COULD BE HOT.**

**WARNING: ALWAYS WEAR SAFETY GLASSES WHEN USING THE SANDER**



**CAUTION: ALWAYS MAKE SURE THE WORK TABLE AND BACKSTOP ARE PROPERLY ADJUSTED AND SECURE BEFORE USE.**

## ON/OFF BUTTONS

The On/Off buttons are located on the front of the sander.

1. Press the GREEN button (I) to turn the sander on.
  2. Press the RED button (O) to turn the sander off.
- If the power supply is interrupted for any reason, the unit will automatically switch off. When power is restored, press the GREEN button to resume work.

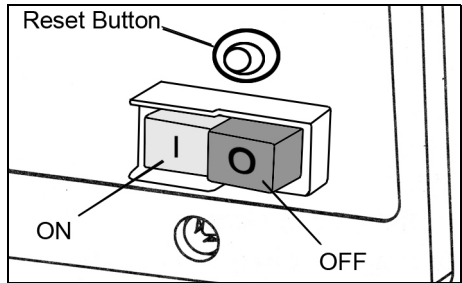

## RESET BUTTON

The machine is fitted with a thermal overload protector. If the motor stops running or fails to start:

1. Wait 5 minutes and then press the reset button.
- If the reset button continually activates contact your CLARKE dealer.

## BELT SANDING

### HORIZONTAL AND VERTICAL SANDING

The sanding belt can be used in the vertical or horizontal position, depending on operator needs and the workpiece.

To change from one position to the other:

1. Loosen the socket head screw using the 6 mm hex wrench provided.

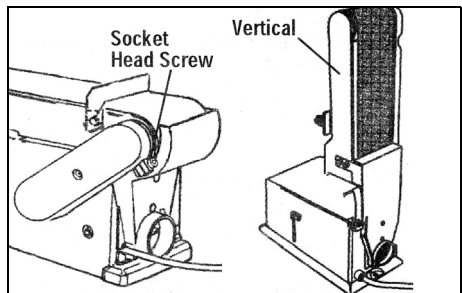

2. Manually move the sanding belt to the desired angle and retighten the socket head screw.

### **SURFACE SANDING ON THE BELT**

When sanding flat broad surfaces on the belt hold the workpiece firmly on the surface of the belt and against the backstop, keeping fingers away from the sanding belt. Consider using a push or hold-down stick.

- Use extra caution when sanding very thin pieces, and when sanding extra long pieces, remove the backstop.

**NOTE:** When using the sander without the backstop, ensure that you have a firm hold on the workpiece at all times and take extra care.

- Apply only enough pressure to allow the sanding belt to remove material.

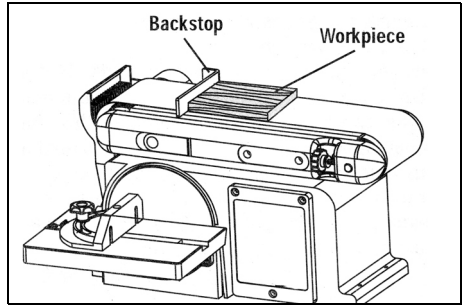

### **SANDING CURVED PIECES**

When sanding inside-curves on the belt sander, always sand on the idler drum end of the belt.

1. Hold the workpiece firmly, keeping fingers away from the sanding belt. Keep the curve pressed firmly against the idler drum, moving the work evenly back and forth across the drum.

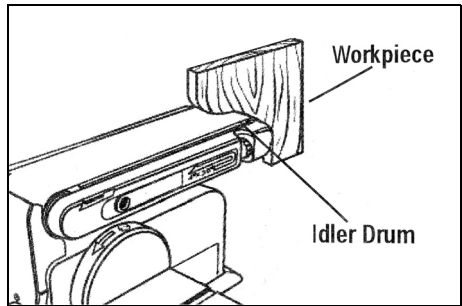

## **SANDING DISC**

### **SANDING OUTSIDE CURVES**

Always sand outside curves using the sanding disc and moving the workpiece from the left side of centre, as shown. Keep the curve pressed firmly against the sanding disc, moving the work evenly from the left side of the sanding disc. Be sure to hold the workpiece firmly against the surface of the table.

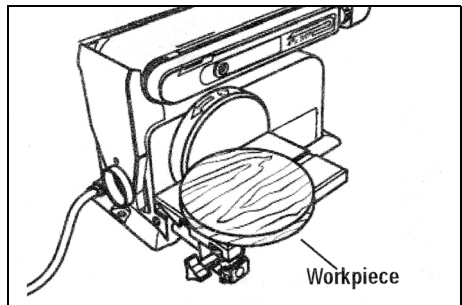

## MITRE GAUGE - DISC SANDER

A mitre gauge can be used on the work table, as shown. The mitre gauge head can be set anywhere up to 60° (right or left) by loosening the lock-knob, setting the mitre gauge head to the desired angle, and tightening the lock-knob.

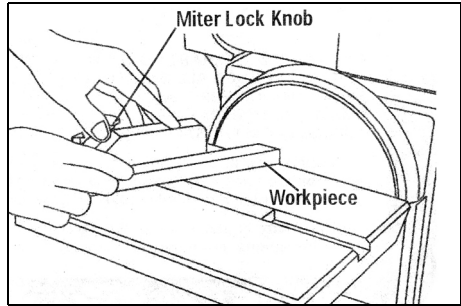

## SANDING SMALL SURFACES USING THE MITRE GAUGE

Use of the mitre gauge is recommended for sanding small end surfaces on the sanding disc.

**NOTE:** Always move the workpiece across the left side (dust chute end of machine) of the sanding disc and be sure to hold the workpiece down tightly onto the table surface.

---

## MAINTENANCE

---



**WARNING: ALWAYS DISCONNECT THE SANDER FROM POWER SOURCE BEFORE MAKING ANY ADJUSTMENTS, INSTALLING BELTS/DISCS.**



CAUTION: SERVICING MUST BE PERFORMED ONLY BY QUALIFIED REPAIR PERSONNEL. SERVICE OR MAINTENANCE PERFORMED BY UNQUALIFIED PERSONNEL COULD RESULT IN A RISK OF INJURY. WHEN SERVICING A TOOL, USE ONLY IDENTICAL REPLACEMENT PARTS. FOLLOW INSTRUCTIONS IN THE MAINTENANCE SECTION OF THIS SERVICE MANUAL. USE OF UNAUTHORISED PARTS OR FAILURE TO FOLLOW MAINTENANCE INSTRUCTIONS MAY CREATE A RISK OF ELECTRIC SHOCK OR INJURY.

1. Clean the sander, belt and disc after each use.
2. Keep the sander dry, clean and free from oil and grease.
3. Store the sander in a safe and dry place, out of reach of children.
4. During normal use, sanding belts and discs can become loaded with sanding debris. Use a stick belt cleaner (available at most hardware stores) to remove build-up.

## REPLACING THE DRIVE BELT

1. Using a cross head screwdriver, remove the screw located in the middle of the cover.
2. Remove the cover.

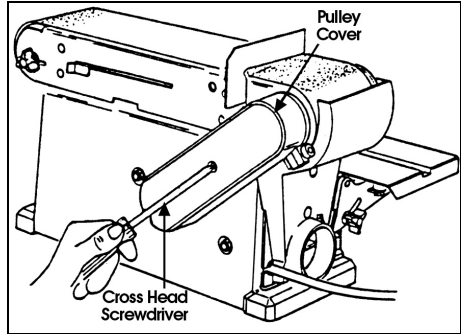

3. Loosen (3) screws to allow the pulleys to move enough to pass the belt around them. Pass the belt around the motor pulley and drive pulley as shown.

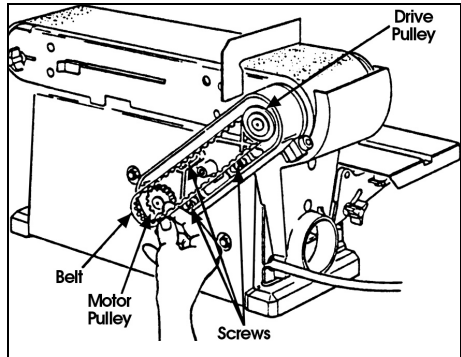

4. Slightly tighten (3) screws. Adjust the tension of the belt by putting a flat blade screwdriver into the adjusting hole. Push up on the screwdriver to increase the tension between pulleys.
5. Tighten screws fully, being careful not to disturb the belt.
6. Test belt tension by placing fingers on either side of belt and squeeze.
  - There should be about a 1/4" give to the belt.

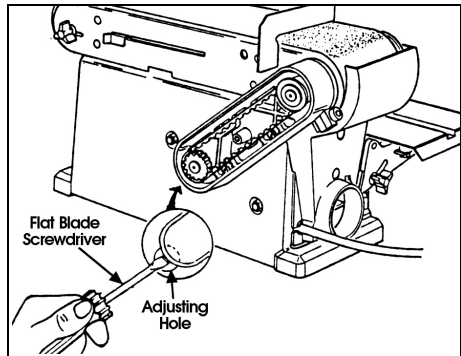

**NOTE:** Excessive tension on the pulley belt may cause increased noise and over load the motor. Excessive looseness may cause the belt to fail prematurely.

7. Replace the pulley cover and position it inside the relief edges of the pulley housing.
8. Using a cross head screwdriver, refit and tighten the flat head screw.

---

## SPECIFICATIONS

---

|   |                         |
|---|-------------------------|
| Motor                                   | 230V, 50Hz, 1ph         |
| Input Power                             | 370 W                   |
| Fuse Rating                             | 13A                     |
| Sanding Disc Diameter                   | 6" (150 mm)             |
| Sanding Belt Size (W x L)               | 4" x 36" (914 x 100 mm) |
| Sanding Belt Speed                      | 450 m/min.              |
| Sanding Table Dimensions (L x W)        | 225 x 160 mm            |
| Table Angle Range                       | 0-45 degrees            |
| Mitre Guide Angle Range                 | 0-60 degrees            |
| Net Weight                              | 18.65 kg                |
| Dimensions (LxWxH)                      | 447 x 363 x 255 mm      |
| Sound Pressure Level dB L <sub>pA</sub> | 91.1 dB (A)             |
| Sound Power Level dB L <sub>WA</sub>    | 79.9 dB (A)             |
| Vibration                               | 3.34 m/s <sup>2</sup>   |
| Part No                                 | 6500413                 |

---

## PARTS AND SERVICING

---

For Parts & Servicing, please contact your nearest dealer, or  
CLARKE International, on one of the following numbers.

**PARTS & SERVICE TEL: 020 8988 7400**  
**PARTS & SERVICE FAX: 020 8558 3622**  
**or e-mail as follows:**  
**PARTS: [Parts@clarkeinternational.com](mailto:Parts@clarkeinternational.com)**  
**SERVICE: [Service@clarkeinternational.com](mailto:Service@clarkeinternational.com)**



# EXPLODED DIAGRAM & PARTS LIST

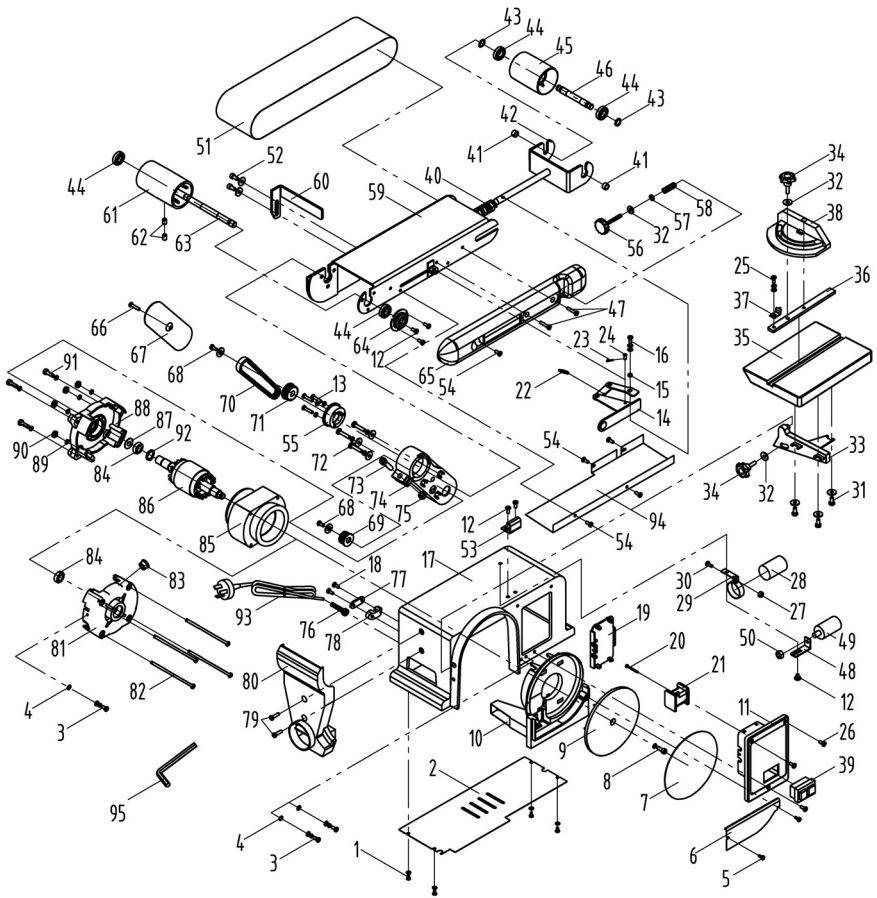

# EXPLODED DIAGRAM & PARTS LIST

| NO | DESCRIPTION  |
|----|--|
| 1  | Phillips Screw + Flat Washer M4x6                    |
| 2  | Baseboard  |
| 3  | Phillips Screw M4x8                                  |
| 4  | Lock Washers 4                                       |
| 5  | Phillips Screw St4.2x10                              |
| 6  | Disc Cover   |
| 7  | Disc Paper 150mm-80#                                 |
| 8  | Socket Head Screw + Lock Washer M6x16                |
| 9  | Disc   |
| 10 | Wheel Box  |
| 11 | Switch Box   |
| 12 | Phillips Screw M5x8                                  |
| 13 | Phillips Screw + Spring Washer M5x25                 |
| 14 | Tension Lever Assy                                   |
| 15 | Bush   |
| 16 | Phillips Screw + Lock Washer + Big Flat Washer M5x16 |
| 17 | Base   |
| 18 | Phillips Screw M4X20                                 |
| 19 | Connecting Box Cover                                 |
| 20 | Phillips Screw St2.9x30                              |
| 21 | Relay 220v-240v                                      |
| 22 | Tension Spring                                       |
| 23 | Cotter Pin 1.6x10                                    |
| 24 | Roll Pin 5x10  |
| 25 | Phillips Screw + Spring Washer + Flat Washer M5x8    |
| 26 | Phillips Screw M4x12                                 |
| 27 | Hex Flange Nut M4                                    |
| 28 | Capacitor 100uf/250v                                 |
| 29 | Capacitor Support                                    |
| 30 | Phillips Screw-plate M4x12                           |
| 31 | Hex Head Bolt + Big Flat Washer M6*12                |
| 32 | Big Flat Washer 6                                    |

| NO | DESCRIPTION                           |
|----|---------------------------------------|
| 33 | Work table Support                    |
| 34 | Miter Gauge Handle                    |
| 35 | Work table                            |
| 36 | Miter Slide                           |
| 37 | Miter Gauge Pointer                   |
| 38 | Miter Gauge                           |
| 39 | Switch Kjd20-2                        |
| 40 | Pressure Spring                       |
| 41 | Guard                                 |
| 42 | Guide Shelf                           |
| 43 | External Circlip D12                  |
| 44 | Bearing 6001-2rs                      |
| 45 | Driven Roller                         |
| 46 | Driven Shaft                          |
| 47 | Phillips Screw M5*25                  |
| 48 | Capacitor Support                     |
| 49 | Capacitor 10uf/450v                   |
| 50 | Hex Nut-plate M8                      |
| 51 | Sanding Belt 100*915mm                |
| 52 | Socket Head Screw + Flat Washer M8x16 |
| 53 | Support                               |
| 54 | Phillips Screw M5x16                  |
| 55 | Bearing Base                          |
| 56 | Belt Adjusting Handle                 |
| 57 | Rubber Washer                         |
| 58 | Adjusting Spring                      |
| 59 | Support Assy                          |
| 60 | Backstop                              |
| 61 | Drive roller                          |
| 62 | Inner Hex Lock Screw M8x12            |
| 63 | Drive Shaft                           |
| 64 | Bearing Cap                           |
| 65 | Support Cover                         |
| 66 | Phillips Screw M5x10                  |
| 67 | Belt Cover                            |

| NO | DESCRIPTION  |
|----|--|
| 68 | Phillips Screw + Special Shaped Lock Washer M5x16  |
| 69 | Motor Shaft Wheel                                  |
| 70 | Drive Belt   |
| 71 | Driven Wheel                                       |
| 72 | Phillips Screw + Spring Washer + Flat Washer M6x25 |
| 73 | Socket Head Bolt M8x25                             |
| 74 | Belt Cover   |
| 75 | Hex Nut M8   |
| 76 | Anti Bending Tail Sleeve                           |
| 77 | Plate 150l   |
| 78 | Cable Clamp  |
| 79 | Phillips Screw M5*20                               |
| 80 | Dust Collecting Cover                              |
| 81 | Front End Housing                                  |
| 82 | Phillips Screw - Plate M6*113                      |
| 83 | Retainer 90#                                       |
| 84 | Bearing 6003-2rs                                   |
| 85 | Stator Wire Package                                |
| 86 | Rotor  |
| 87 | Wave Spring Washer 35                              |
| 88 | Rear End Cover                                     |
| 89 | Spring Washer                                      |
| 90 | Hex Nut-plate M6                                   |
| 91 | Hex Bolt + Spring Washer M6x20                     |
| 92 | External Circlip D17                               |
| 93 | Power Cable  |
| 94 | Protection Plate                                   |
| 95 | Socket Head Wrench M6x90x32                        |

# DECLARATIONS OF CONFORMITY



## DECLARATION OF CONFORMITY

This is an important document and should be retained.

We hereby declare that this product(s) complies with the following directive(s):

- 2014/30/EU Electromagnetic Compatibility Directive
- 2006/42/EC Machinery Directive
- 2011/65/EU Restriction of Hazardous Substances, (amended by 2015/863)

The following standards have been applied to the product(s):

- EN 62841-1:2015, EN ISO 12100:2010, EN 55014-1:2017+A11:2020, EN 55014-2:2015,
- EN 61000-3-2:2019, EN 61000-3-3:2013+A1:2019.

The technical documentation required to demonstrate that the product(s) meet(s) the requirement(s) of the aforementioned directive(s) has been compiled and is available for inspection by the relevant enforcement authorities.

The CE mark was first applied in: 2008

**Product Description:** 4 x 6 Belt Disc Sander  
**Model number(s):** CS4-6E  
**Serial / batch Number:** N/A  
**Date of Issue:** 26/02/2021

Signed:

J.A. Clarke  
Director



## DECLARATION OF CONFORMITY

This is an important document and should be retained.

We hereby declare that this product(s) complies with the following UK legislation:

- Electromagnetic Compatibility Regulations 2016,
- Supply of Machinery (Safety) Regulations 2008,
- The Restriction of the Use of Certain Hazardous Substances in Electrical and Electronic Equipment Regulations 2012.

The following standards have been applied to the product(s):

- EN 62841-1:2015, EN ISO 12100:2010, EN 55014-1:2017+A11:2020, EN 55014-2:2015,
- EN 61000-3-2:2019, EN 61000-3-3:2013+A1:2019.

The technical documentation required to demonstrate that the product(s) meet(s) the requirement(s) of the aforementioned legislation has been compiled and is available for inspection by the relevant enforcement authorities.

This product was placed onto the market: 2008

**Product Description:** 4 x 6 Belt Disc Sander  
**Model number(s):** CS4-6E  
**Serial / batch Number:** N/A  
**Date of Issue:** 26/02/2021

Signed:

J.A. Clarke  
Director

# A SELECTION FROM THE VAST RANGE OF

# Clarke®

## QUALITY PRODUCTS



### **AIR COMPRESSORS**

From DIY to industrial, Plus air tools, spray guns and accessories.

### **GENERATORS**

Prime duty or emergency standby for business, home and leisure.

### **POWER WASHERS**

Hot and cold, electric and engine driven - we have what you need

### **WELDERS**

Mig, Arc, Tig and Spot. From DIY to auto/industrial.

### **METALWORKING**

Drills, grinders and saws for DIY and professional use.

### **WOODWORKING**

Saws, sanders, lathes, mortisers and dust extraction.

### **HYDRAULICS**

Cranes, body repair kits, transmission jacks for all types of workshop use.

### **WATER PUMPS**

Submersible, electric and engine driven for DIY, agriculture and industry.

### **POWER TOOLS**

Angle grinders, cordless drill sets, saws and sanders.

### **STARTERS/CHARGERS**

All sizes for car and commercial use.



# PARTS & SERVICE: 0208 988 7400

**Parts Enquiries**  
[Parts@clarkeinternational.com](mailto:Parts@clarkeinternational.com)

**Servicing & Technical Enquiries**  
[Service@clarkeinternational.com](mailto:Service@clarkeinternational.com)

SALES: UK 01992 565333 or Export 00 44 (0)1992 565335

**Clarke** INTERNATIONAL Hemnall Street, Epping, Essex CM16 4LG  
[www.clarkeinternational.com](http://www.clarkeinternational.com)