

Clarke®



PRESSURISED SANDBLASTER

MODEL NO: CPSB200

PART NO: 7640128

OPERATION & MAINTENANCE INSTRUCTIONS

LS0117

INTRODUCTION

Thank you for purchasing this Clarke Pressurised Sandblaster.

Before you try to use this product, read this manual and follow the instructions carefully. In doing so you will ensure your safety and the safety of others around you. You can also look forward to a purchase that gives you long and satisfactory service.

GUARANTEE

This product is guaranteed against faulty manufacture for a period of 12 months from the date of purchase. Please keep your receipt which will be required as proof of purchase.

This guarantee is invalid if the product is found to have been abused or tampered with in any way, or not used for the purpose for which it was intended.

Faulty goods should be returned to their place of purchase, no product can be returned to us without prior permission.

This guarantee does not effect your statutory rights.

CONSUMABLES

Please be aware that certain parts of this sandblaster will wear, and require replacing and that these parts may not be covered by your guarantee.

The speed at which certain parts wear depends on the abrasiveness of the materials used. Replacement parts are available from your nearest Clarke International dealer.

WHAT IS SUPPLIED

1 x Abrasive Tank Assembly	1 x Funnel
2 x Handlebars (with screws, washers and nuts)	4 x Nozzles (2 mm, 2.5 mm, 3 mm and 3.5 mm)
2 x Wheels and fixing kit	1 x Protective Hood
1 x Wheel Axle	1 x Sieve
1 x Sand Hose	1 x Instruction Manual

CONTENTS

INTRODUCTION	2
GUARANTEE	2
CONSUMABLES	2
WHAT IS SUPPLIED	2
CONTENTS	3
GENERAL SAFETY RULES	4
ASSEMBLY	6
FIT THE PRESSURE GAUGE TO THE TANK	6
FIT THE HANDLE BARS TO THE TANK	6
ASSEMBLE THE FRAME	7
ATTACH FRONT LEG	7
ATTACH THE HOSE	7
OPERATION	8
SAFETY AND HEALTH CONSIDERATIONS	8
LOADING THE ABRASIVE	9
TO START BLASTING	9
TO STOP BLASTING	11
RELEASING PRESSURE FROM THE TANK	11
MAINTENANCE	12
AIR FILTER	12
REPLACING THE NOZZLE	13
SPECIFICATIONS	14
PARTS & SERVICING	14
EXPLODED DIAGRAM & PARTS LIST	15
DECLARATION OF CONFORMITY	17
NOTES.....	18
NOTES	19

GENERAL SAFETY RULES



Warning: Compressed air can be dangerous. Ensure that you are thoroughly familiar with all precautions relating to the use of compressors and compressed air supply.

1. **Read this instruction manual** before connecting the sandblaster to a compressor.
2. **Do not use any silica based abrasives with this sandblaster.** Silica based abrasives have been linked to severe respiratory disease. Always use recommended abrasives. Abrasives used in this sandblaster may be covered by COSHH Regulations.
3. **Read this manual carefully.** Learn the sandblasters applications and limitations, as well as potential hazards specific to it.
4. **Do not expose the sandblaster to moisture.** Don't use this sandblaster in damp or wet locations, Keep out of rain.
5. **Keep work area clean and well lit.** Cluttered or dark work areas invite accidents,
6. **Keep children away.** All children should be kept away from the work area. Never let a child handle a tool without strict adult supervision.
7. **Do not operate this sandblaster if under the influence of alcohol or drugs.** Read warning labels on prescriptions to determine if your judgment or reflexes are impaired while taking drugs. If there is any doubt, do not attempt to operate,
8. **Use safety equipment.** Dust mask, non-skid safety shoes, hard hat, or hearing protection should be used in appropriate conditions.
9. **Don't overreach,** Keep proper footing and balance at all times when operating this sandblaster.
10. **Always disconnect the sandblaster from the air supply** and release pressure from the tank before storing, servicing, or changing accessories.
11. **Use clamps** or other practical means to secure and support the work piece to a stable platform. Do not hold the work by hand or against your body.
12. **Do not point the sandblaster** at anyone or any objects other than the intended work object.
13. **Check your sandblaster regularly for damage,** If part of the sandblaster is damaged it should be carefully inspected to make sure that it can perform its intended function correctly. If in doubt, the part should be repaired. Refer all servicing to a qualified technician. Consult your dealer for advice.
14. **Do not** attempt to operate this sandblaster near flammable materials or combustibles. Failure to comply may cause serious injury.

15. **Always check** to make sure that the trigger is not on before connecting the sandblaster to air supply.
16. **Store the sandblaster** out of the reach of children and untrained persons. Tools may be dangerous in the hands of untrained users.
17. **Drain water trap periodically during use.** Do not allow moisture to fill more than 1/2 of the water trap bowl. Do not leave water standing in the water trap when storing the sandblaster.
18. **Do not allow the sandblaster to sit pressurised while unattended or not in use.**
19. **Periodically check** the Valves, hoses and nozzles that carry the abrasive medium after it leaves the pressure tank these are subjected to the abrasive blasting action so will wear out more quickly than other components.
20. **Release the air pressure in the tank** before opening. See "Releasing Pressure from the Tank" section, Make sure the pressure gauge reads "0" before opening the tank. Do not attempt any maintenance on the sandblaster until the pressure gauge reads "0", and it has been disconnected from the air supply.
21. **Maintain correct air pressure** whenever working. Do not allow pressure to exceed 125 psi. If the safety valve does not release excess air pressure, stop all work and release pressure from the tank (see "Releasing Pressure from the Tank" section)., investigate the cause and correct it before continuing use
22. **Always** make sure there is adequate ventilation. Do not sandblast in confined areas,
23. In the case of injury seek expert medical advice immediately.

ASSEMBLY

FIT THE PRESSURE GAUGE TO THE TANK

1. Screw the pressure gauge onto the sandblaster as shown in Fig 1.
 - PTFE Tape may be required to give a perfect seal.

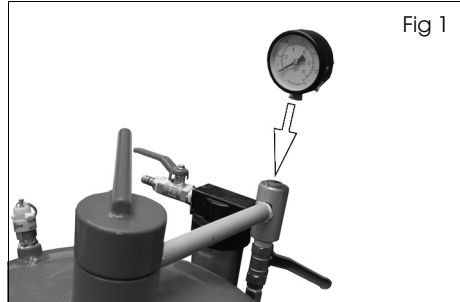

FIT THE HANDLE BARS TO THE TANK

1. Lay the tank on a flat level surface (such as a workbench or table top), with the handlebar mounting brackets facing up, as shown in Fig 2.
 - Handlebars are labelled "LEFT" and "RIGHT."
2. Align the holes in the left handlebar with the handlebar mounting brackets on the left side of the tank.
3. Place a washer onto each of the four handlebar mounting screws. Insert a screw through each of the holes in handlebar and mounting brackets,
4. Place a nut onto each of the screws and firmly tighten in place with a wrench.
5. Repeat steps 2-4 for the right handlebar.

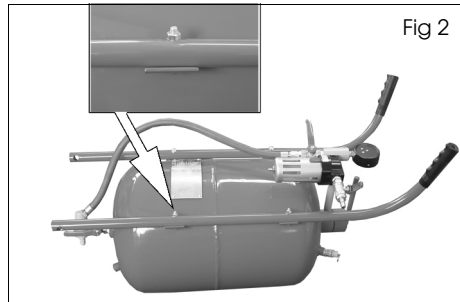

ASSEMBLE THE FRAME

1. Slide the axle through the axle holes located at the bottom of the handlebars, see Fig 3.
2. Slide a washer onto each end of the axle.
3. Place a wheel onto each end of the axle then slide a washer onto the axle.
4. Use the circlip provided to secure the wheel, see Fig 4.
5. Place the cover over the wheel.

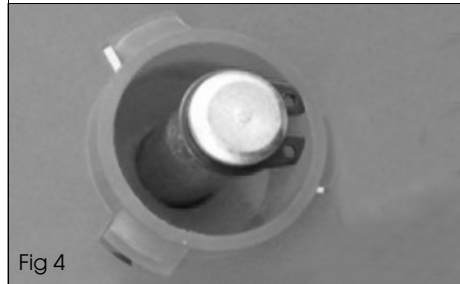
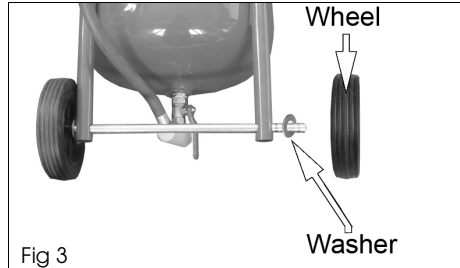

ATTACH FRONT LEG

1. Roll the tank over so that handlebars are now facing down.
2. Align the holes of the front foot with the holes in the foot mount on the front side of the tank, see Fig 5.
3. Insert a split pin through the holes and bend it so the front foot cannot slide off the foot mount.

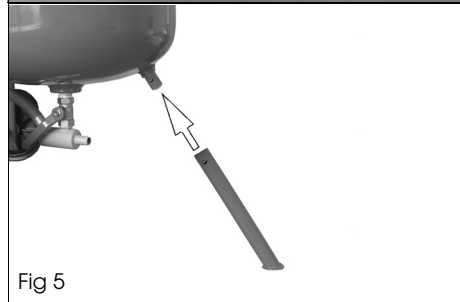

ATTACH THE HOSE

1. Slide the hose onto the outlet pipe on the bottom of the sandblaster as shown in Fig 6.
2. Tighten the clip shown to secure the hose.
3. Connect the sandblasting gun to the other end of the hose in a similar manner.

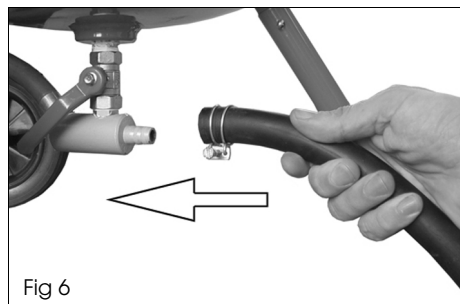

OPERATION



WARNING: ALWAYS WEAR YOUR HOOD, DUST MASK AND HEAVY DUTY CANVAS GLOVES WHEN OPERATING THE SANDBLASTER.

WARNING: BEFORE OPERATING YOUR SANDBLASTER, INSPECT EACH CONNECTION, DOUBLE CHECKING TO MAKE SURE THAT ALL ARE TIGHT AND PROPERLY SEALED.

WARNING: THIS SANDBLASTER IS NOT INTENDED FOR USE WITH SILICA BASED ABRASIVES. WHICH HAVE BEEN LINKED TO SEVERE RESPIRATORY DISEASE. ALWAYS USE SILICA SUBSTITUTES SUCH AS CLARKE GLASS BEAD ABRASIVE.

SAFETY AND HEALTH CONSIDERATIONS

- Before opening the tank make sure that it is not pressurised. Ensure the gauge reads "0". If it does not, release pressure from the tank (See page 11).
- Disconnect the compressor before opening the tank. Protect yourself and those around you from "over-spray". Remember that your sandblaster is shooting a powerful spray of abrasive material. Do not point it at yourself or anyone around you.
- Wear protective clothing including hood, and heavy duty gloves when using this sandblaster.
- Wear a filter or mask over your mouth when using this tool. You will create a cloud of abrasive material and debris which is dangerous to inhale.
- Protect anything around you that may be damaged by the abrasive spray or particles. Nothing vulnerable to contamination, damage or with a fine surface should be near your sandblaster.

LOADING THE ABRASIVE

- To prevent clogging, ensure that the abrasive you use is dry.
- While you may re-use abrasive, remember that abrasive grit/material does wear out. After use, abrasive becomes smoother and rounder, thus reducing its effectiveness.

NOTE: Re-using abrasive may also cause clogging due to fine debris contained in the mixture from prior use.

1. Close the air supply valve by turning it to the closed position, see Fig 7.
2. Press the trigger to release any pressure from the tank.
 - Make sure the pressure gauge reads "0".
3. Remove the filler cap.
4. Using the sieve and funnel supplied, pour the selected abrasive medium into the tank, see Fig 8.
 - Do not fill the tank more than $\frac{3}{4}$ full.
 - If humidity in your region is 90% or more, only fill the tank $\frac{1}{2}$ full and check the water trap more frequently.
5. Replace the filler cap ensuring the O-ring is in place.

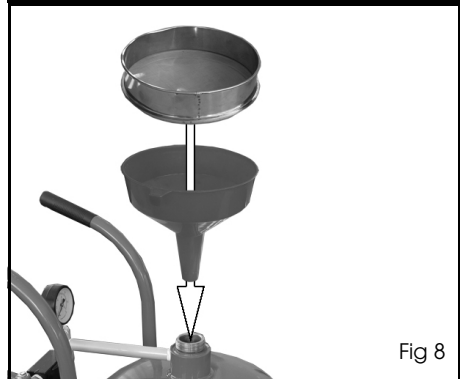
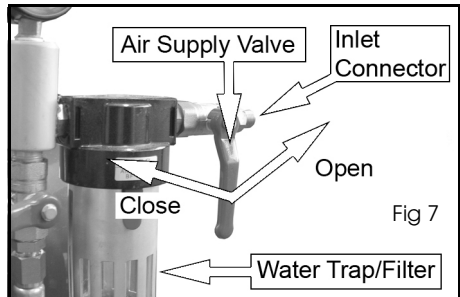

NOTE: Place your air compressor in another room if possible to prevent damage from the intake of abrasive dust laden air.

TO START BLASTING

NOTE: Start with all valves in the closed position. Following the instructions below will help prevent clogging in the delivery hose, outlet manifold and the trigger.

1. Connect the compressor to the inlet connector shown in Fig 7.

2. Start the compressor and open the air supply valve, see Fig 9.
 - The tank will start to pressurise.

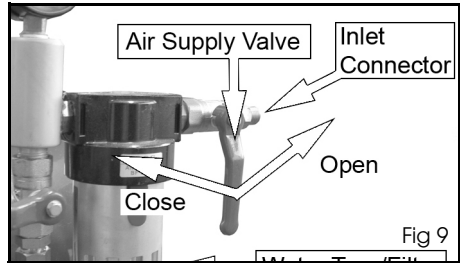

3. Test the safety valve by pulling up on the valve as shown in Fig 10.
 - Air will hiss out when the valve is pulled.



4. Open the throttle valve, Fig 11.
5. Check for leaks at the filler cap and along all hoses and fittings as the system pressurises. If leaks are observed, release the pressure from the tank and repair leaks immediately.

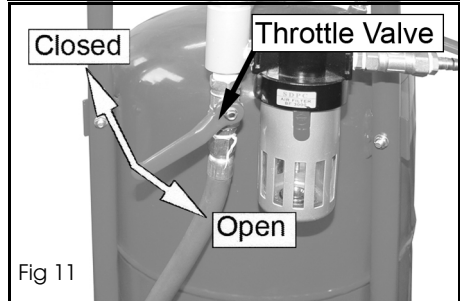

6. Press and hold the trigger until air is flowing through it.
7. With the trigger being held open, slowly open the abrasive control valve as shown in Fig 12 until abrasive material begins to flow out of the trigger.
8. Adjust the abrasive control valve until the desired amount of abrasive material is flowing through the trigger,

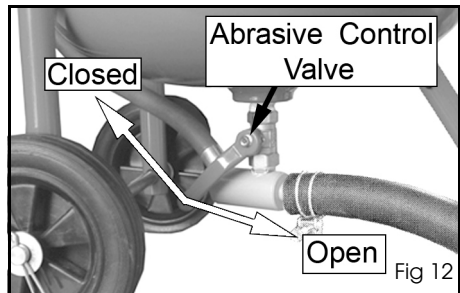

- Choose a larger nozzle for a broader spray pattern. Choose a smaller nozzle for more focused spray.
- Adjust air pressure with the throttle valve. Adjust abrasive flow with abrasive control valve,
- Watch for abrasive clogging. If this happens, release pressure from the tank if necessary and replace the abrasive with drier or cleaner abrasive.

TO STOP BLASTING

1. While continuing to press and hold the Trigger, turn the abrasive control valve to the closed position, see Fig 13.
2. When you can see no abrasive is coming out of the trigger, you can stop the air flow by releasing the trigger. By doing this you are ensuring a clean and cog-free manifold, hose, and trigger.
3. ALWAYS clean the gun thoroughly after use.

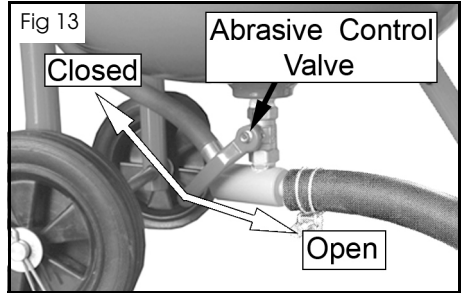

RELEASING PRESSURE FROM THE TANK

1. When you have finished blasting, close the abrasive control valve, see Fig 14.
2. Press and hold the trigger to expel any remaining abrasive material from the abrasive hose.
3. When you notice only air (no abrasive) is coming out of the trigger, release the trigger and close the air supply valve, see Fig 15.
4. Ensure the throttle valve is open, see Fig 16.
5. Press the trigger until air stops flowing and the pressure gauge reads "0".
6. Disconnect the air supply hose from the supply valve.

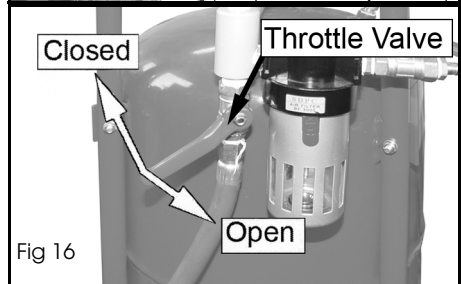
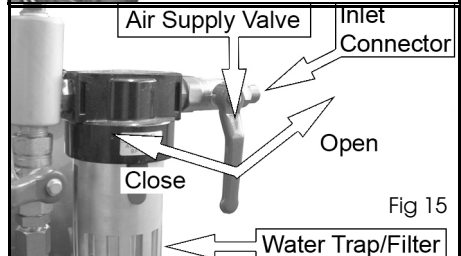
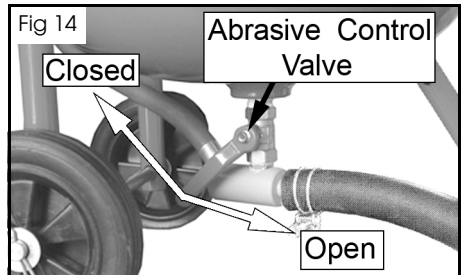

MAINTENANCE



WARNING: DISCONNECT THE SANDBLASTER FROM THE AIR SUPPLY AND RELEASE ANY PRESSURE IN THE TANK AND HOSE BEFORE CHANGING ACCESSORIES, ATTEMPTING TO MOVE THE SANDBLASTER OR PERFORM ANY MAINTENANCE.

1. Keep your sandblaster clean, and protect it from damage.
2. When initially pressurising, check for leaks at the top of the tank and at all hoses and fittings.
3. Leaking joints maybe repaired by replacing worn or damaged parts or using teflon tape.
4. Check for worn abrasive hose and fittings,
5. Watch for leaks, blistering, bulging or thinning of the hose.
6. Replace any parts which appear worn.

AIR FILTER

DRAINING

Condensation will collect in the air filter, which must be drained manually.

1. Drain the air filter by pulling down on the drain plug until all the water comes out, see Fig 17.

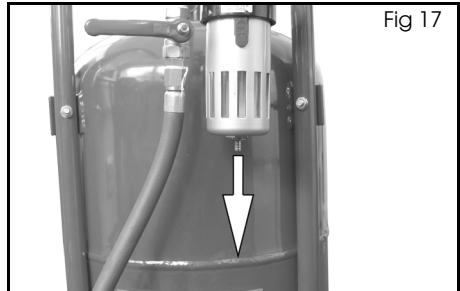

CLEANING/REPLACING

1. Press the release catch and unscrew the condensation chamber, see Fig 18.

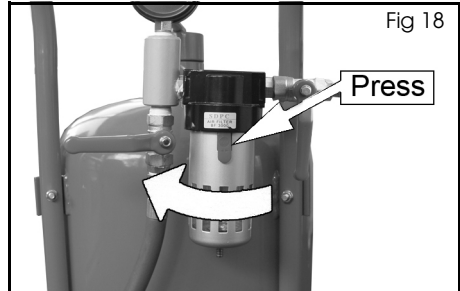

2. Unscrew the filter as shown in Fig 19 and wipe clean.

NOTE: Do not use harsh or abrasive chemicals when cleaning the condensation chamber.

3. Refit the condensation chamber.

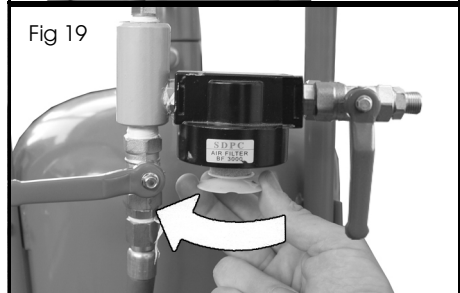

REPLACING THE NOZZLE

NOTE: ONLY use identical replacement parts when servicing.

After 10-12 hours of blasting time the nozzle should be checked for wear. The nozzle will wear out over time and should be replaced when the hole is no longer round or the abrasive media does not flow smoothly through. To replace the nozzle:

1. Disconnect the sandblasting gun from the air hose.
2. Unscrew the nozzle adaptor, located at the front of the sandblasting gun.
3. Remove the old nozzle.
4. Insert a new nozzle.
 - A pack of replacement nozzles are available from your Clarke dealer Part number 7640132.
5. Replace the nozzle adaptor and firmly screw it onto sandblasting gun.

SPECIFICATIONS

	CPSB200
Sand Grade Type	Above 80 grit
Abrasive Material	Aluminium Oxide, Bank Sand, Beach Sand, Glass Beads
Tank Capacity (working)	63 Litres (13.85 Gallons)
Operating Pressure	65 - 125 PSI (4.4 - 8.6 Bar)
Flow Rate Required	12 - 20 CFM (at 125 psi)
Compressor Size	3 - 10 HP
Nozzle Sizes	2, 2.5, 3, 3.5 mm
Dimensions (L x W x H)	400 x 300 x 850 mm
Weight (empty)	23.85 kg

PARTS & SERVICING

For Parts & Servicing, please contact your nearest dealer, or CLARKE International, on one of the following numbers.

**PARTS & SERVICE TEL:
020 8988 7400**

**PARTS & SERVICE FAX:
020 8558 3622**

or e-mail as follows:

**PARTS: Parts@clarkeinternational.com
SERVICE: Service@clarkeinternational.com**

EXPLODED DIAGRAM & PARTS LIST

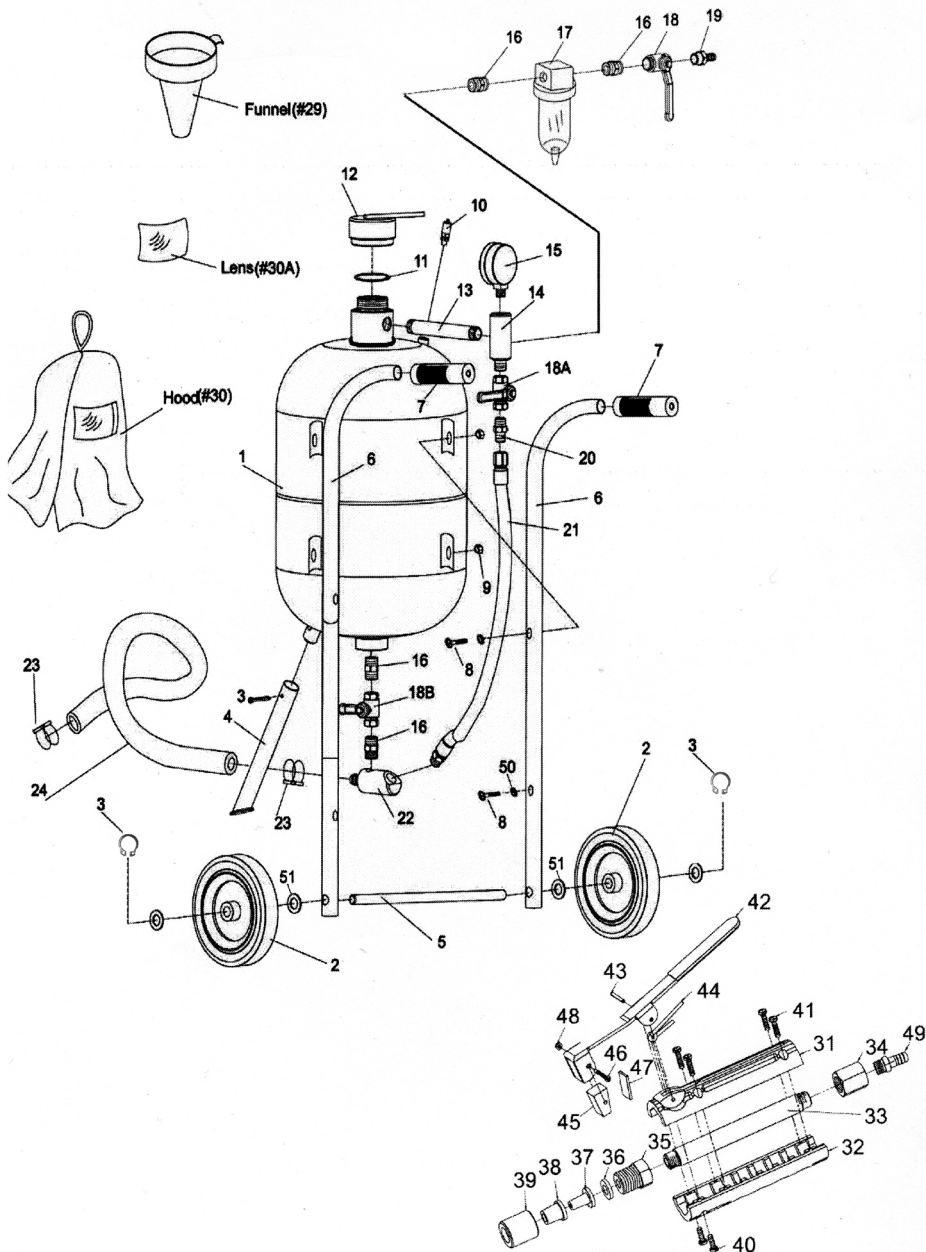

EXPLODED DIAGRAM & PARTS LIST

NO	DESCRIPTION	PART NO
1	Tank	HTCPSB20001
2	Wheel	HTCPSB20002
3	Circlip	HTCPSB20003
4	Front Leg	HTCPSB20004
5	Axle	HTCPSB20005
6	Handle Bars	HTCPSB20006
7	Handle Grips	HTCPSB20007
8	Pan Head Screws	HTCPSB20008
9	Hex Nuts	HTCPSB20009
10	Safety Valve	HTCPSB20010
11	O-Ring	HTCPSB20011
12	Tank Filler Cap	HTCPSB20012
13	Connecting Pipe	HTCPSB20013
14	Intake Manifold	HTCPSB20014
15	Pressure Gauge	HTCPSB20015
16	3/8" Connector	HTCPSB20016
17	Water Trap / Filter	HTCPSB20017
18	3/8" Brass Air Supply Valve	HTCPSB20018
18A	3/8" Brass Throttle Valve	HTCPSB20018A
18B	3/8" Steel Abrasive Control Valve	HTCPSB20018B
19	Inlet Connector	HTCPSB20019
20	Connector	HTCPSB20020
21	Air Hose	HTCPSB20021
22	Abrasive Outlet Manifold	HTCPSB20022
23	Hose Clamps	HTCPSB20023
24	Abrasive Hose	HTCPSB20024
29	Funnel	HTCPSB20029
30	Hood	HTCPSB20030
30A	Lens for Hood	HTCPSB20030A
31	Upper Gun Body	HTCPSB20031
32	Lower Gun Body	HTCPSB20032
33	Metal Pipe	HTCPSB20033
34	Inlet Connector	HTCPSB20034
35	adaptor	HTCPSB20035

NO	DESCRIPTION	PART NO
36	O-Ring	HTCPSB20036
37	Ceramic Nozzle	HTCPSB20037
38	Rubber adaptor	HTCPSB20038
39	Nozzle Cap Nut	HTCPSB20039
40	Screw ST 4.2 x 16	HTCPSB20040
41	Screw ST 4.2 x 12	HTCPSB20041
42	Trigger	HTCPSB20042
43	Spring Pin	HTCPSB20043
44	Spring	HTCPSB20044
45	Rubber Pad	HTCPSB20045
46	Screw M3 x 25	HTCPSB20046
47	Hard Alloy Pad	HTCPSB20047
48	Nut M3	HTCPSB20048
49	Hose adaptor	HTCPSB20049
50	Washer	HTCPSB20050
51	Washer	HTCPSB20051

DECLARATION OF CONFORMITY



Clarke[®]
INTERNATIONAL

Hemndall Street, Epping, Essex CM16 4LG

DECLARATION OF CONFORMITY

This is an important document and should be retained.

We hereby declare that this product(s) complies with the following directive(s):

97/23/EC Pressure Equipment Directive

The following standards have been applied to the product(s):

ASME VIII DIV1

The technical documentation required to demonstrate that the product(s) meet(s) the requirement(s) of the aforementioned directive(s) has been compiled and is available for inspection by the relevant enforcement authorities.

The CE mark was first applied in: 2009

Product Description: Pressurised Sand Blaster
Model number(s): CPSB200
Serial / batch Number: n/a
Date of Issue: 11/01/2011

Signed:

J.A. Clarke
Director

NOTES



A SELECTION FROM THE VAST RANGE OF

Clarke®

QUALITY PRODUCTS

AIR COMPRESSORS

From DIY to industrial, Plus air tools, spray guns and accessories.

GENERATORS

Prime duty or emergency standby for business, home and leisure.

POWER WASHERS

Hot and cold, electric and engine driven - we have what you need

WELDERS

Mig, Arc, Tig and Spot. From DIY to auto/industrial.

METALWORKING

Drills, grinders and saws for DIY and professional use.

WOODWORKING

Saws, sanders, lathes, mortisers and dust extraction.

HYDRAULICS

Cranes, body repair kits, transmission jacks for all types of workshop use.

WATER PUMPS

Submersible, electric and engine driven for DIY, agriculture and industry.

POWER TOOLS

Angle grinders, cordless drill sets, saws and sanders.

STARTERS/CHARGERS

All sizes for car and commercial use.



PARTS & SERVICE: 0208 988 7400

E-mail: Parts@clarkeinternational.com or Service@clarkeinternational.com

SALES: UK 01992 565333 or Export 00 44 (0)1992 565335

Clarke® INTERNATIONAL Hemnall Street, Epping, Essex CM16 4LG
www.clarkeinternational.com