



AIR NAIL GUN

MODEL: CNG1C

Part No. 3110390



OPERATING & MAINTENANCE
INSTRUCTIONS



SPECIFICATIONS

Min. Hose Size (ID)	6mm (1/4")
Air Inlet Connector	10mm Quick Fit
Ave. Air Consumption	0.47 cfm
Operating Pressure	4 - 7bar (60-100psi)
Air Pressure Max	8bar (116psi)
Nail Size	18gauge/15-50mm
Magazine Capacity	100
Drive Speed	200Shots/min
Sound Power Level	101dB _{WA}
Weight	1.4kg
Dimensions LxWxH	255x54.5x249
Part No	3110390

Please note that the details and specifications contained herein, are correct at the time of going to print. However CLARKE International reserve the right to change specifications at any time without prior notice. Always consult the machine's data plate

RESTRICTIONS OF USE

This Nail Gun is suitable for use on materials such as:

- Soft wood, Hardwood • MDF • Plywood • Hardboard • Fibreboard
- Corkboard • Flexible Plastics • Leather, Fabrics • PVC, Polythene sheet
- Foam Rubber

This Nail Gun is NOT suitable for use on materials such as:

- Hard Laminates • Brittle Plastics • Metals (other than light foils)

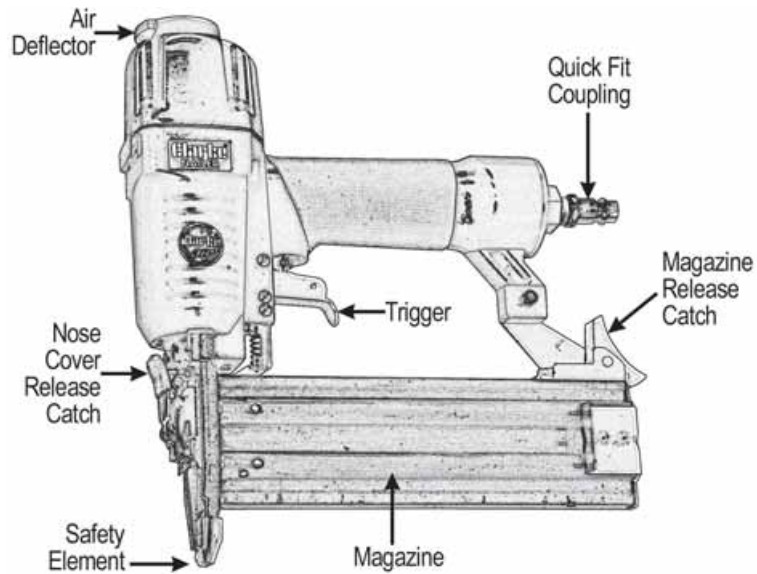

Please read these instructions carefully before operating the tool

Thank you for purchasing this CLARKE Air Nail Gun

Before using the device, please read this leaflet thoroughly and carefully follow the instructions given. In doing so you will ensure the safety of yourself and that of others around you, and you can also look forward it giving long and satisfactory service.

GUARANTEE

This CLARKE product is guaranteed against faulty manufacture for a period of 12 months from the date of purchase. Please keep your receipt as proof of purchase.

This guarantee is invalid if the product is found to have been abused or tampered with in any way, or not used for the purpose for which it was intended.

Faulty goods should be returned to their place of purchase, no product can be returned to us without prior permission.

This guarantee does not effect your statutory rights.

SAFETY PRECAUTIONS

IMPORTANT

Failure to follow these precautions could result in personal injury, and/or damage to property.

1. When operating this tool, **ALWAYS** wear:
 - a. approved impact resistant SAFETY GOGGLES. (Eye glasses are NOT safety glasses)
 - b. EAR DEFENDERS
 - c. a good pair of INDUSTRIAL GLOVES
2. **ALWAYS** disconnect the tool from the air supply when not in use, and before carrying out any maintenance
3. **ALWAYS** keep a safe distance between yourself and others when using the tool.
4. **ALWAYS** Maintain the tool with care. Keep it clean for best/safest performance.
5. **NEVER** wear ill fitting clothing, remove watches and rings.
6. **NEVER** overreach. Keep your proper footing and balance at all times.
7. **NEVER** force or misuse the tool. It will do a better and safer job at the rate for which it was designed.
8. **NEVER** abuse hoses or connectors. NEVER carry a tool by the hose, or yank it to disconnect from the air supply. Keep hoses away from heat, oil and sharp edges. Check hoses for leaks or worn condition before use, and ensure that all connections are secure.
9. **NEVER** use with an air supply greater than 8bar (110 PSI), at the tool.
10. **NEVER** modify the tool in any way.
11. **NEVER** remove any labels. Damaged labels should be replaced.
12. **NEVER** point the tool at anyone.
13. **NEVER** carry the tool with your finger on the trigger.
14. **NEVER** use any other type of gas to operate this tool. Use compressed air ONLY.
15. **NEVER** load the tool with Nails BEFORE connecting to an air supply.
16. **NEVER** load the tool with the trigger depressed
17. **NEVER** use this tool if any part is damaged. Have it inspected and repaired by a competent technician
18. **NEVER** modify this tool in any way. Use it ONLY for the purpose for which it is designed.
19. **NEVER** fire tool at an incline.. it must be perpendicular to the work surface.
20. **NEVER** drive in Nails at the edge of a work surface, as the edge could fail and fly off, endangering yourself or others in the vicinity.

AIR SUPPLY

WARNING!

Compressed air can be dangerous. Ensure that you are thoroughly familiar with all precautions relating to the use of compressors and compressed air supply.

Tools of this type, operate on a wide range of air pressures. It is recommended that air pressure be set to between 60 and 100psi. at the tool when running.

Higher pressure and unclean air will shorten the tools' life and could be a safety hazard.

Water in the air line will cause damage to the tool, ensure it is properly maintained at all times.

The recommended procedure to connect this tool to an air supply, is shown on page 11.

The air inlet used for connecting air supply, is a 10mm Quick Fit type.

Line pressure, or hose ID., should be increased to compensate for unusually long air hoses (over 10M). Minimum hose dia. should be 6mm (1/4") ID., and fittings should have the same inside dimensions.

ASSEMBLY

Ensure the tool is not loaded, then, with the air supply turned OFF, connect the air line to the Nailer at the Quick Fit coupling.

With your fingers well away from the trigger, and the tool pointed away from you, and anyone in the vicinity, depress the magazine catch, pull out the magazine and load with appropriate nails or staples...as shown, Push the magazine back until it locks in position, - Your Nailer/Stapler is now ready for use.

Turn ON the air supply, and check for air



OPERATION

leaks. If any are apparent, rectify before proceeding. Ensure the operating pressure is set to between 4-7bar (60-100psi), depending upon the size of nail used and type of material being worked. The harder the material, and bigger the nail, the higher the pressure.

Hold the tool so that it is at right angles to the work. Lower it so that the Safety Element contacts the work surface, and is forced upwards. This movement releases the Trigger, which may now be pulled, driving in the nail.

CLEARING A JAM

Should the gun jam, turn OFF the air supply and pull the trigger in order to ensure the airline is not under pressure. Release the nose catch (A Fig. 1), and clear the jammed nail from the within the nose. Secure the nose with the catch, turn ON the air supply and proceed to use the Nailer.

MAINTENANCE

Daily before use.

1. Drain water from compressor air tank, and air line.
2. Check and clean, if fitted, the air inlet gauze filter.
3. A bottle of CLARKE Air Line Oil** is supplied with the kit. Squirt a few drops of oil (approx. 3cc), into the air inlet.

This should be carried out regardless of whether or not an air line lubricator is used.

During Use.

For lubricating the internal components when in operation, an air line lubricator should be used, with Clarke Air Line Oil**, adjusted to 2 drops per minute. (see p.11)

If an Air line lubricator is NOT used, this procedure should be repeated after every two to three hours of use.

Storage.

If the Nailer is to be stored, or is idle for longer than 24 hours, run a few drops of Clarke Air Line Oil** into the air inlet before storing.

Notes

Be aware that factors other than the tool may effect its operation and efficiency such as reduced compressor output, excessive drain on the airline, moisture or restrictions in the line, or the use of connectors of improper size or poor condition which will reduce air supply.

Grit or gum deposits in the tool may also reduce efficiency. This condition can be corrected by cleaning the air strainer, if fitted, and flushing out the tool with gum solvent oil, or failing this, the tool should be disassembled, thoroughly cleaned, dried and reassembled.

If the tool runs erratically or becomes inefficient, and the air supply is sound, dismantle the piston assembly and replace worn or damaged parts, or take the tool to your CLARKE dealer.

**Clarke Air Line Oil is available from your CLARKE dealer part no. 3050825.

IMPORTANT:

The use of parts other than CLARKE replacement parts may result in safety hazards, decreased tool performance and will invalidate your warranty.

ACCESSORIES

A wide range of Airline accessories is available, including Filter/Regulators, Lubricators, High Pressure Hoses from 5 to 100 Metres, Whip hose etc. Contact your CLARKE dealer for further information, or CLARKE International Sales Department on 01992 565333

CONSUMABLES

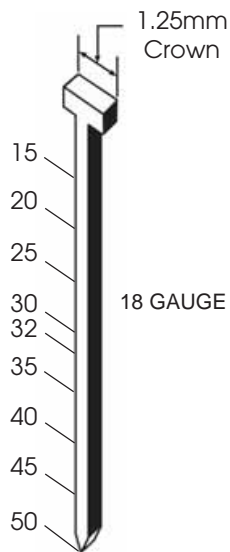

Nails - 18 Gauge - 1.25mm Crown

Length	Part No:
15mm	1800413
20mm	1800415
30mm	1800417
32mm	1800419
35mm	1800421
40mm	1800423
45mm	1800425
50mm	1800427

PARTS DIAGRAM

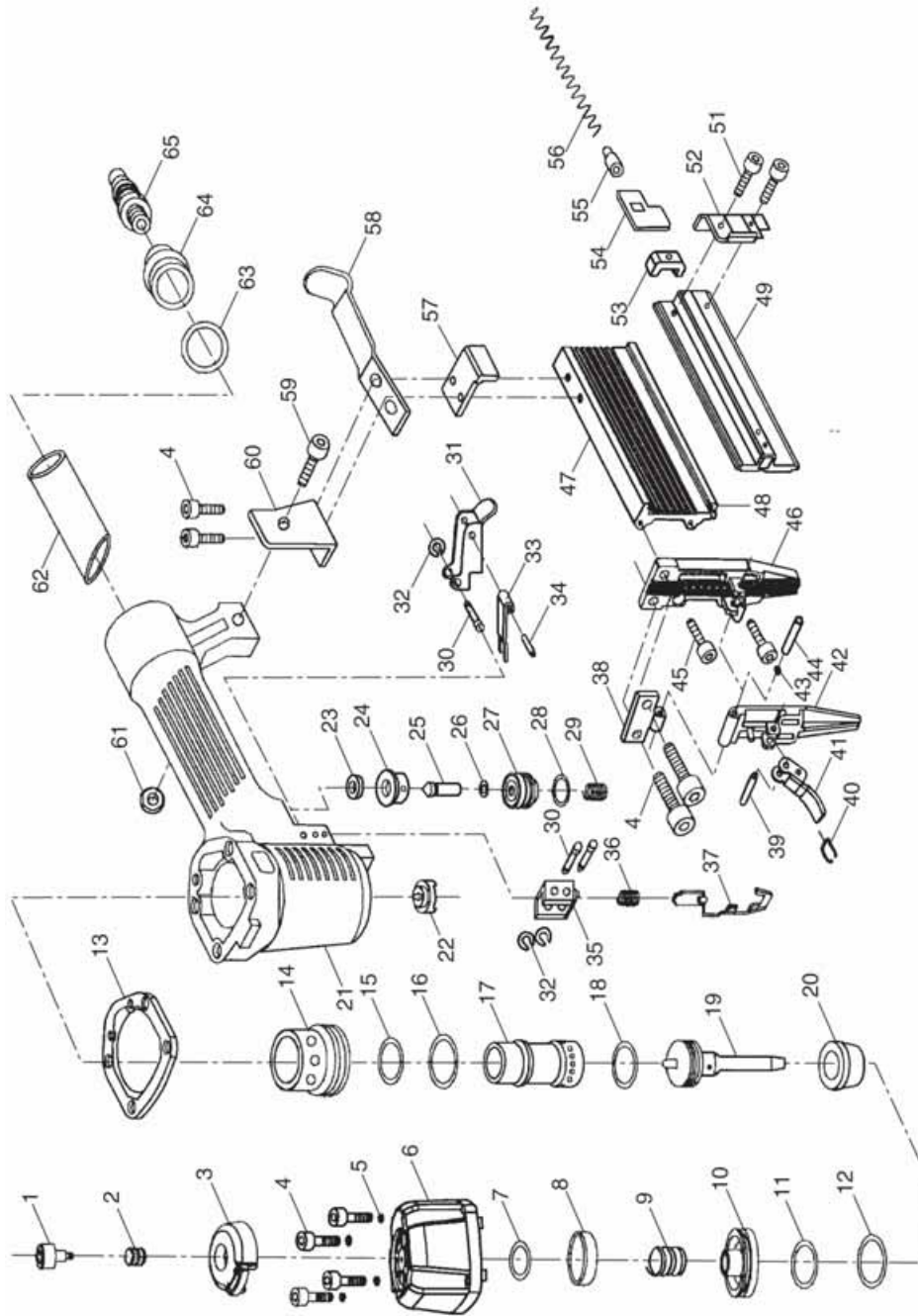

PARTS LIST

No. Description	Part No.	No. Description	Part No.
1 Hex Skt. Hd. Bolt	HTCNG1C01	33 Bearing Plate	HTCNG1C33
2 Deflector Spring	HTCNG1C02	34 Pin 2.5x16	HTCNG1C34
3 Air Deflector	HTCNG1C03	35 Bracket	HTCNG1C35
4 Bolt M5x50	HTCNG1C04	36 Pusher Spring	HTCNG1C36
5 Spring Washer	HTCNG1C05	37 Safety Element	HTCNG1C37
6 Cylinder Head	HTCNG1C06	38 Spacer	HTCNG1C38
7 O-Ring 3.7x2.4	HTCNG1C07	39 Pin 4x20	HTCNG1C39
8 Sealing Washer	HTCNG1C08	40 Clasp	HTCNG1C40
9 Compression Spring	HTCNG1C09	41 Quick Release Handle	HTCNG1C41
10 Piston	HTCNG1C10	42 Nose Cover	HTCNG1C42
11 O-Ring 31.2x2.5	HTCNG1C11	43 Retaining Ring	HTCNG1C43
12 O-Ring 24.8x3.5	HTCNG1C12	44 Pin 2.5x16	HTCNG1C44
13 Gasket	HTCNG1C13	45 Bolt M4x12	HTCNG1C45
14 Exhaust Collar	HTCNG1C14	46 Guide Nose	HTCNG1C46
15 O-Ring 30x1.8	HTCNG1C15	47 Label	HTCNG1C47
16 O-Ring 42.6x2.35	HTCNG1C16	48 Nail Carrier	HTCNG1C48
17 Cylinder	HTCNG1C17	49 Magazine Slide Cover	HTCNG1C49
18 O-Ring 21x3	HTCNG1C18	52 End Plate	HTCNG1C52
19 Main Piston	HTCNG1C19	53 Clamp	HTCNG1C53
20 Shock Absorber	HTCNG1C20	54 Nail Pusher	HTCNG1C54
21 Gun Body	HTCNG1C21	55 Spring Adapter	HTCNG1C55
22 Rubber Washer	HTCNG1C22	56 Compression Spring	HTCNG1C56
23 Rectangle Washer	HTCNG1C23	57 Fixed Plate	HTCNG1C57
24 Trigger Valve Seat	HTCNG1C24	58 Fixed Lever	HTCNG1C58
25 Trigger Valve Stem	HTCNG1C25	59 Bolt M4x16	HTCNG1C59
26 O-Ring 1.7x2	HTCNG1C26	60 Support Bracket	HTCNG1C60
27 Trigger Valve Guide	HTCNG1C27	61 Nut M4	HTCNG1C61
28 O-Ring 11.2x2	HTCNG1C28	62 Rubber Grip	HTCNG1C62
29 Compression Spring	HTCNG1C29	63 O-Ring 36.3 x 3.55	HTCNG1C63
30 Pin	HTCNG1C30	64 End Cap	HTCNG1C64
31 Trigger	HTCNG1C31	65 Q/Release Coupling	HTCNG1C65
32 E-ring 2.5	HTCNG1C32		

RECOMMENDED AIR SUPPLY CONNECTION

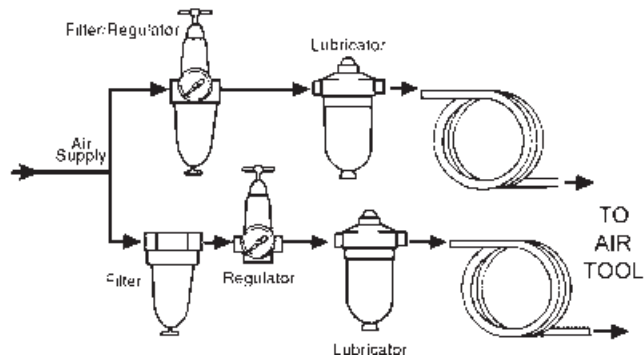

DECLARATION OF CONFORMITY

We declare that these products comply to the following standards/directives

- **BS EN 792-13: 2000**

Model No: **CNG1C**

Serial or Batch number: **See product data plate**

signature: _____

L. E. Fergusson
L. E. Fergusson
SERVICE MANAGER

SPARE PARTS & SERVICING CONTACTS

For Spare Parts and Service, please contact your nearest dealer, or CLARKE International, on one of the following numbers.

PARTS & SERVICE TEL: 020 8988 7400

PARTS & SERVICE FAX: 020 8558 3622

or e-mail as follows:

PARTS: Parts@clarkeinternational.com

SERVICE: Service@clarkeinternational.com