

Clarke®



CORDLESS IMPACT WRENCH

MODEL NO: CIR18Li

PART NO: 4500615

OPERATING & MAINTENANCE INSTRUCTIONS



ORIGINAL INSTRUCTIONS

GC0217

INTRODUCTION

Thank you for purchasing this CLARKE Impact Wrench.

Before attempting to use this product, please read this manual thoroughly and follow the instructions carefully. In doing so you will ensure the safety of yourself and that of others around you, and you can look forward to your purchase giving you long and satisfactory service.

GUARANTEE

This product is guaranteed against faulty manufacture for a period of 12 months from the date of purchase. Please keep your receipt which will be required as proof of purchase.

This guarantee is invalid if the product is found to have been abused or tampered with in any way, or not used for the purpose for which it was intended.

Faulty goods should be returned to their place of purchase, no product can be returned to us without prior permission. This guarantee does not effect your statutory rights.

SAFETY PRECAUTIONS

WORK ENVIRONMENT

1. Keep the work area clean and tidy and free from trip hazards.
2. Do not wear loose clothing or jewellery. Tie long hair out of the way.
3. If wearing gloves, make sure that there is no frayed material that could catch in rotating parts.
4. Keep children and visitors away - do not let children handle the wrench.
5. Do not use in damp or wet conditions. Keep the work area well lit. Do not use where a risk of fire or explosion is present.
6. Although the wrench may be used outdoors, DO NOT leave it exposed to the elements. Avoid direct sunlight, direct heat, rain/moisture etc.
7. ALWAYS keep body and clothing dry. Never work in damp area without adequate insulation against electric shock.
8. ALWAYS store this product in a dry, secure place out of reach of children or untrained users.
9. ALWAYS keep equipment dry, especially the battery & battery charger.
10. NEVER over-reach. Keep proper footing and balance at all times and adopt a comfortable, well balanced working position for ongoing work.

GENERAL USE

1. This product vibrates during use. Vibration may be harmful to your hands or arms. Stop using the wrench if discomfort, a tingling feeling or pain occurs and seek medical advice before resuming use.
2. ALWAYS use ear defenders for prolonged work. Exposure to high noise levels can cause permanent hearing problems.
3. Always wear impact resistant eye protection in case of flying projectiles.
4. ALWAYS stay alert and use common sense - do not use this product when you are tired or under the influence of alcohol or medication.
5. ALWAYS ensure the workpiece is firmly secured leaving both hands free to control the wrench. Hold the impact wrench correctly and be ready to control sudden movements.
6. ALWAYS check for any damage or condition that could affect the wrench's operation. Any damaged part should be properly repaired.
7. NEVER force or misuse the wrench. It will do a better and safer job at the rate for which it was designed.

8. NEVER use the wrench if it is defective / operating abnormally.
9. NEVER carry the wrench with your finger on the trigger.
10. NEVER abuse the mains cable of the battery charger. Never yank the cable to disconnect it from the socket. Keep the cable away from sharp edges/hot surfaces.
11. NEVER use this wrench for any purpose other than described in this booklet.
12. NEVER carry out any alterations or modifications to this product.
13. NEVER wipe the wrench clean with solvents. Wipe plastic parts with a soft cloth, slightly dampened with soapy water.
14. NEVER attempt any repairs yourself. If you have a problem with this product contact your local CLARKE dealer.
15. ALWAYS use an approved cable extension suitable for the power rating of the battery charger (see specifications), the conductor size should also be at least the same size or larger than that on the charger. When using a cable reel, always unwind the cable completely.

IMPACT WRENCH SAFETY INSTRUCTIONS

1. Use only impact wrench sockets....DO NOT use standard sockets which could shatter and cause injury.
2. ALWAYS finish tightening nuts with a torque wrench to the correct torque as recommended by the vehicle manufacturer.
3. ALWAYS avoid excessive use of the wrench. When tightening a nut or bolt, always avoid over tightening.
4. ALWAYS ensure the wrench has stopped before putting it down after use.
5. ALWAYS only use sockets which are specified for impact wrench use.
6. ALWAYS set the forward/reverse selection bar to neutral when changing sockets or when the wrench is not required for immediate use. This will avoid accidental starting.







LITHIUM-ION BATTERY USE AND CARE

1. Only use the wrench with the battery pack supplied. Use of any another battery pack may create a risk of injury and fire.
2. Do not charge the battery when the room temperature is below 10°C. Do not store the battery where the temperature may exceed 40°C (104°F)
3. When the battery pack is not in use, keep it away from metal objects that could make a connection from one terminal to another. Shorting the battery terminals together may cause burns or a fire.

4. Dispose of spent batteries correctly as they contain Lithium-ion. They are recyclable and should be taken to a recycling centre to be disposed of as stipulated by local regulations. Do not incinerated battery as it may explode when exposed to fire. Do not attempt to open, disassemble, modify or service a battery pack.
5. Handle batteries so as to avoid damage, fire, corrosion or personal injury.
6. Never crush, puncture, short external contacts or dispose of in fire or water.
7. Never attempt recharging the battery by means of an engine generator or a DC power source.
8. Never attempt to disassemble the battery.
9. Never allow a leaking battery to contact your person. If you come into contact with battery liquid take the following immediate action:
 - Skin contact: Wash immediately with soap and water, then wash flesh in either lemon juice or vinegar.
 - Eye contact: Wash with a strong solution of boric acid and seek immediate medical attention

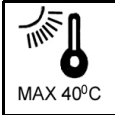
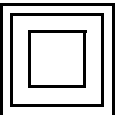
SAFETY SYMBOLS

The full technical specification of the battery charger is printed on a label on the charger. The meanings of the markings and symbols are shown below

	Read instruction manual before use		Suitable for indoor use only
	Wear eye protection when using this product.		Maximum Temperature (battery pack only)
	Class 2 Double Insulated		Do not Incinerate (battery pack only)
	Weee directive compliance required for Lithium-Ion batteries.		Do not immerse in water (battery pack only)

Please keep these instructions in a safe place for future reference.

ELECTRICAL CONNECTIONS



WARNING! READ THESE ELECTRICAL SAFETY INSTRUCTIONS THOROUGHLY BEFORE CONNECTING THE PRODUCT TO THE MAINS SUPPLY.

The battery charger for this product is provided with a standard 13 amp, 230 volt (50Hz), BS 1363 plug, for connection to a standard, domestic electrical supply. Should the plug need changing at any time, ensure that a plug of identical specification is used.



WARNING! THE WIRES IN THE POWER CABLE OF THIS PRODUCT ARE COLOURED IN ACCORDANCE WITH THE FOLLOWING CODE: BLUE = NEUTRAL BROWN = LIVE

If the colours of the wires in the power cable of this product do not correspond with the markings on the terminals of your plug, proceed as follows.

- The wire which is coloured **Blue** must be connected to the terminal which is marked **N** or coloured **Black**.
- The wire which is coloured **Brown** must be connected to the terminal which is marked **L** or coloured **Red**.

Plug must be BS1363/A approved.

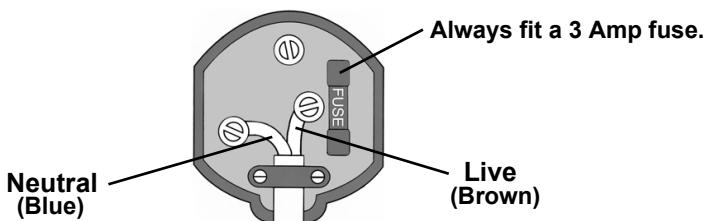

Ensure that the outer sheath of the cable is firmly held by the clamp

We strongly recommend that this machine is connected to the mains supply via a Residual Current Device (RCD)

If in any doubt, consult a qualified electrician. DO NOT attempt any repairs yourself.



This symbol indicates that this is a Class II product, and does not require an earth connection.

PRODUCT OVERVIEW



The CIR18Li is a professional, cordless impact wrench which is rechargeable using the mains power adaptor. The key design features are shown above.

Upon receipt, check the components against the following list. Any damage or deficiency should be reported to your Clarke dealer immediately.

- 18V Impact Wrench with battery pack fitted
- Battery-charging unit
- Spare battery pack (4000 mAh)

BATTERY CHARGING

The battery will have been shipped in a low charge state and will require charging before use.

1. Press the battery release clip on the front of the battery pack and slide the battery pack from the impact wrench.



2. Plug the charger into a 230V power supply and switch ON.

- The green POWER ON light will illuminate to show the unit is connected to the mains supply.

3. Insert the battery pack into the battery charger, as shown, noting that it will only fit one way.

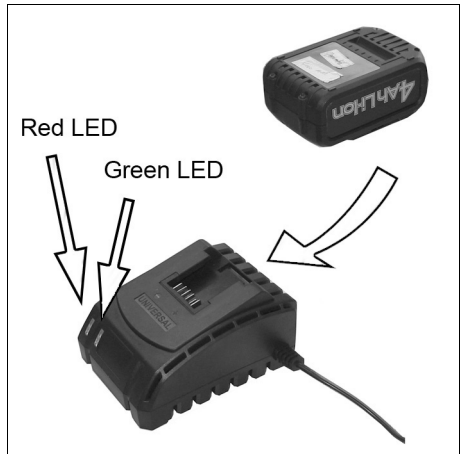

- The red light will flash to indicate the battery is charging.

- When charging is complete (typically after about 3 hours), both lights will come on. The battery pack can be considered charged and be removed. Charging time will be dependant upon the initial state of the battery.

- When charging a new battery pack, it may initially not accept full charge. This is common & does not indicate a fault. It can be recharged fully after it has been discharged a couple of times.

- If charging does not take place, ensure all connections are clean.

- In the event of both LED indicators flashing rapidly, it can be assumed that either the battery has become too hot, in which case it should be left to cool down, or that a battery cell has failed and the battery should be replaced.

4. After charging, switch off and unplug the charger from the power supply.

5. Remove the battery pack from the charger and slide it back onto the impact wrench until it clips into place.

The battery pack should slide in easily. If it is not to be fitted immediately, ensure that the metal contacts are protected to avoid the possibility of a short circuit which would cause battery damage. For maximum battery life, we recommend that you maintain the battery in a fully charged state.

OPERATION



CAUTION: MAKE SURE THAT THE IMPACT WRENCH IS OFF USING THE SELECTOR BAR BEFORE ATTACHING OR REMOVING A SOCKET. ALWAYS TAKE CARE TO USE THE CORRECT SIZE SOCKET FOR BOLTS AND NUTS. AN INCORRECT SOCKET WILL CAUSE DAMAGE TO THE BOLT OR NUT.

FITTING A SOCKET

1. Align the chosen socket and simply push it onto the anvil. Use only $\frac{1}{2}$ " square drive impact sockets as listed on page 12.
2. Squeeze the trigger to start the impact wrench. Release the trigger to stop.

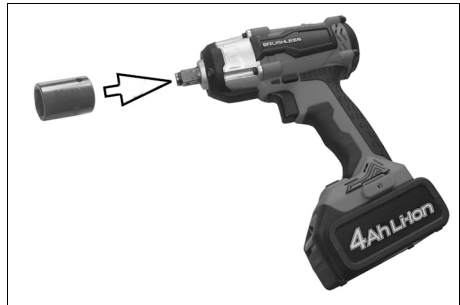

FORWARD/REVERSE SELECTION

1. Select the direction of operation by pushing the selector bar in the appropriate direction.
 - The direction of rotation is shown on the end face of the selector bar.
 - When the selector bar is in the central position the trigger is locked.
2. Always check the direction of rotation before operation.

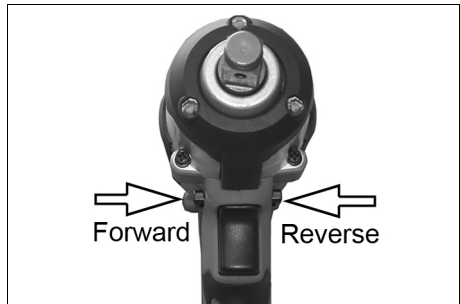

SPEED SELECTION

1. Three running speeds are available by moving the rocker switch shown.

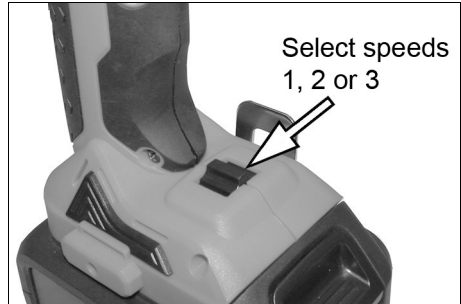

LOOSENING A NUT

1. Fit the appropriate socket to the square drive of the impact wrench.
2. With the FORWARD/REVERSE switchbar in the REVERSE running position, hold the wrench firmly and pull the trigger. The nut will be impacted repeatedly until it is loosened.



WARNING: ENSURE THAT THE CORRECT SOCKET IS BEING USED FOR THE NUTS ON YOUR PARTICULAR VEHICLE. AN INCORRECT SOCKET SIZE WILL DAMAGE THE HEADS OF THE BOLTS/NUTS.

NOTE: As the battery becomes discharged the power available will drop. The battery will cut out when a low state of charge is reached. This is normal and is a design feature to protect the battery from deep discharge. If this occurs, re-charge the battery as described on page 8.

3. After use, recharge the battery pack as shown on page 8. Avoid leaving the batteries in a discharged state.

TIGHTENING A NUT

1. Start the nut by hand, ensuring it is not cross threaded, then with the appropriate socket fitted to the impact wrench, place it on the nut.
2. With the FORWARD/REVERSE selector bar in the forward running position, and holding the wrench firmly, pull the trigger.
3. Install each nut in turn until it is 'nipped' up only - do not tighten fully. When all nuts are secure, tighten further but take care to prevent over-tightening.
4. ALWAYS finish tightening with a torque wrench to the manufacturers recommended torque.

BELT HOOK

The impact wrench is provided with a belt hook. This can be fitted to either side of the main housing, adjacent to the battery and is retained by a single screw.



MAINTENANCE

All bearings etc, in this wrench are lubricated with a sufficient amount of high grade lubricant for the machines lifetime under normal operating conditions, therefore no further lubrication is required.

Refer to your CLARKE dealer if internal maintenance is required.

Check the battery charger power cable to ensure it is free from cracks, bare wires etc.

Avoid using solvents when cleaning plastic parts, most plastics are susceptible to damage from the various types of commercial solvents. Keep the unit clean by wiping with a dry cloth. DO NOT use solvents as a cleaning agent.

Your Clarke impact wrench has been designed to give long and trouble free service. If, however, having followed the instructions in this booklet carefully, you encounter problems, take the unit to your local Clarke dealer.

Always store the wrench and its charger in the case supplied. Store in a clean, dry place, out of reach of children when not in use.

ENVIRONMENTAL PROTECTION



Li-ion

Do not dispose of this product with general household waste. All tools, accessories and packaging should be sorted, taken to a recycling centre and disposed of according to the laws governing Waste Electrical and Electronic Equipment.

Through the purchase of this product, the customer is taking on the obligation to deal with the WEEE in accordance with the WEEE regulations in relation to the treatment, recycling & recovery and environmentally sound disposal of the WEEE.

In effect, this means that this product must not be disposed of with general household waste. It must be disposed of according to the laws governing Waste Electrical and Electronic Equipment (WEEE) at a recognised disposal facility.

BATTERY DISPOSAL

Dispose of old batteries in accordance with local authority regulations. Do not incinerate or crush, as this will increase the risk of explosion and contamination. If the battery contents come into contact with skin or the eyes, rinse with clean water for several minutes and seek medical advice immediately afterwards.

ACCESSORIES

A wide range of impact wrench accessories is available from your nearest Clarke dealer, for further information, contact your nearest dealer, or telephone Clarke International Sales department on 01992 565300.

Suitable impact wrench compatible socket sets include the following:

Part No	Model No	Description
3110437	CAT37B	11 piece 1/2"square drive (metric)
1800311	CIS12/17B	17 piece 1/2"square drive (metric/AF)
1800305	CIS9/32	32 piece 3/8" & 1/2"square drive (metric/AF)
1800345	CIS12/7M	7 piece 1/2"square drive universal joint (metric)
1800350	CIS12/7MD	7 piece 1/2"square drive universal joint (deep) metric
1800355	CIS12/6H	6 piece 1/2"square drive hex key set (metric)
1800360	CIS12/6S	7 piece 1/2"square drive TRX-Star

COMPONENT PARTS LIST

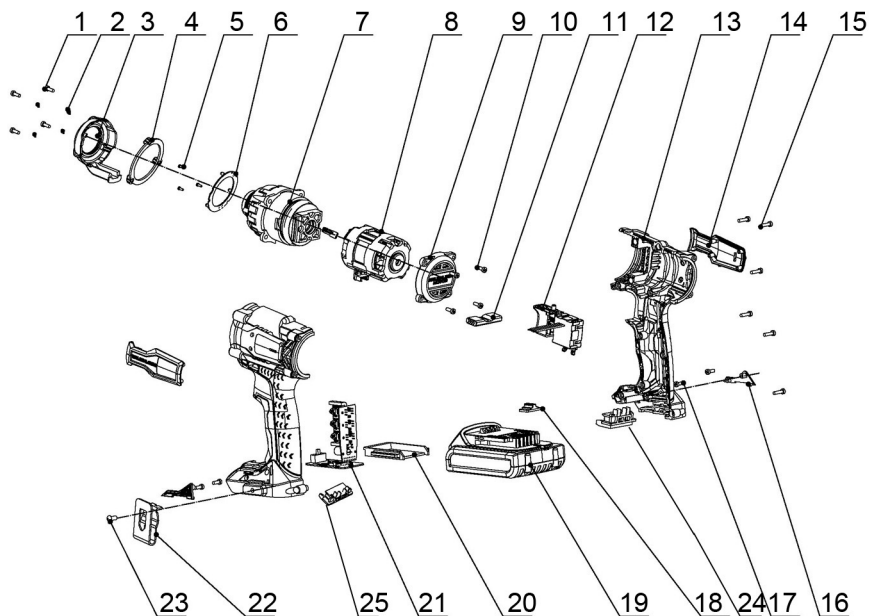

No	Description
1	Screw M4 x 18
2	Spring Washer
3	Rubber
4	Surround
5	Screw
6	Lamp Assembly
7	Impact Drive Assembly
8	Motor
9	Rear Cover
10	Screw st3 x 14
11	Forward/Reverse Selector Bar
12	Switch Assembly
13	Casing

No	Description
14	Side Pad
15	Screw st3x12
16	Baseboard Fastener
17	Screw
18	3-Position Button
19	Battery
20	Baffle
21	Control Board
22	Belt Clip
23	Screw M4 x 8
24	3-speed Control Switch
25	Connecting Block
	Battery charger (not shown)

SPECIFICATIONS

FEATURE	SPECIFICATION
Weight	1.80 kg
Dimensions (L x W x H)	178 x 90 x 256 mm
Size of spindle	1/2"
Motor Speed	20,000 rpm
Max rated tightening torque	450 Nm
Rated no-load speeds	1000 rpm(low), 1500 rpm(med), 2000 rpm (high)
Impacts/minute	0-22500
Duty Cycle	S1 (continuous)
IP Rating	IP20
Charger insulation class	II
Input voltage	230V/50 Hz
Output voltage	18V DC
Battery Type	Lithium-Ion
Charging Time	1.5 hours
Battery pack capacity	4000 mAh
Charger Fuse Rating	3 Amp
Sound pressure level	76.9 dB LpA
Sound power level	87.9 dB LWA
Uncertainty Factor (K)	3 m/s ²
Vibration Level	7.24 m/s ²
Uncertainty Factor (K)	1.5 m/s ²

Please note that the details and specifications contained herein, are correct at the time of going to print. However, CLARKE International reserve the right to change specifications at any time without prior notice.

DECLARATION OF CONFORMITY



Clarke[®]
INTERNATIONAL

Hemnall Street, Epping, Essex CM16 4LG

DECLARATION OF CONFORMITY

This is an important document and should be retained.

We hereby declare that this product(s) complies with the following directive(s):

2014/30/EU *Electromagnetic Compatibility Directive.*

2006/42/EC *Machinery Directive.*

2011/65/EU *Restriction of Hazardous substances.*

The following standards have been applied to the product(s):

EN 60745-1+A11:2010, EN 60745-2-2:2010, BS EN 60335-1:2012+A11:2014, BS EN 62233:2008,

BS EN60335-2-29:2004+2010, EN 55014-1:2006+A1:2009+A2:2011, EN 55014-2:2015,

EN 61000-3-2:2014, EN 61000-3-3:2013.

The technical documentation required to demonstrate that the product(s) meet(s) the requirement(s) of the aforementioned directive(s) has been compiled and is available for inspection by the relevant enforcement authorities.

The CE mark was first applied in: 2016

Product Description: 18 Volt Li-Ion Brushless Impact Wrench ½ Inch.
Model number(s): CIR 18 LI.
Serial / batch Number: N/A
Date of Issue: 06/12/2016.

Signed:



.....

J.A. Clarke
Director

A SELECTION FROM THE VAST RANGE OF

Clarke®

QUALITY PRODUCTS

AIR COMPRESSORS

From DIY to industrial, Plus air tools, spray guns and accessories.

GENERATORS

Prime duty or emergency standby for business, home and leisure.

POWER WASHERS

Hot and cold, electric and engine driven - we have what you need

WELDERS

Mig, Arc, Tig and Spot. From DIY to auto/industrial.

METALWORKING

Drills, grinders and saws for DIY and professional use.

WOODWORKING

Saws, sanders, lathes, mortisers and dust extraction.

HYDRAULICS

Cranes, body repair kits, transmission jacks for all types of workshop use.

WATER PUMPS

Submersible, electric and engine driven for DIY, agriculture and industry.

POWERTOOLS

Angle grinders, cordless drill sets, saws and sanders.

STARTERS/CHARGERS

All sizes for car and commercial use.



PARTS & SERVICE: 0208 988 7400

E-mail: Parts@clarkeinternational.com or Service@clarkeinternational.com

SALES: UK 01992 565333 or Export 00 44 (0)1992 565335

Clarke® INTERNATIONAL Hemnall Street, Epping, Essex CM16 4LG
www.clarkeinternational.com