

ELIANTHO®

WOODWORKER



12in (305mm) CONTRACTOR'S SAW

Model No. CCS12

Part No. 6460000

CE

0204

OPERATING & MAINTENANCE INSTRUCTIONS

Serial/Batch No:.....



WARNING

Considerable noise is generated by this type of equipment.
Ear protection should be used at all times

PARTS & SERVICE CONTACTS

For Spare Parts and Service, please contact your nearest dealer, or CLARKE International,
on one of the following numbers.

PARTS & SERVICE TEL: 020 8988 7400

PARTS & SERVICE FAX: 020 8558 3622

or e-mail as follows:

PARTS: Parts@clarkeinternational.com

SERVICE: Service@clarkeinternational.com



Thank you for purchasing this CLARKE 305mm (12") Contractors Saw which is designed for INDOOR USE ONLY

Before operating the machine, please read this leaflet thoroughly and follow the instructions carefully. In doing so you will ensure the safety of yourself and that of others around you, and you can look forward to it giving you long and satisfactory service.

GUARANTEE

This CLARKE product is guaranteed against faulty manufacture for a period of 12 months from the date of purchase. Please keep your receipt as proof of purchase.

This guarantee is invalid if the product is found to have been abused or tampered with in any way, or not used for the purpose for which it was intended.

Faulty goods should be returned to their place of purchase, no product can be returned to us without prior permission.

This guarantee does not effect your statutory rights.

CONTENTS

Page

General Safety Precautions	4
Additional precautions for Table Saws	6
Features	7
Unpacking & Parts Identification	8
Principal Parts Diagram	9
Assembly	10
Electrical Connections	15
Adjustments	16
Operation:	
a. Rip Cutting	17
b. Cross Cutting	17
c. Bevel Cutting	18
Maintenance	
Saw Blade Removal/Replacement	18
Parts List	20
Part Diagram	21
Specifications	22
Accessories	22
Parts and Service Contacts	2 and 22

GENERAL SAFETY RULES FOR OPERATING MACHINERY

WARNING:

As with all machinery, there are certain hazards involved with their operation and use. Exercising respect and caution will considerably lessen the risk of personal injury. However, if normal safety precautions are overlooked or ignored, personal injury to the operator or damage to property, may result.



- **DISCONNECT the MACHINE** from the power supply before servicing, making adjustments or when changing accessories such as blades, etc.

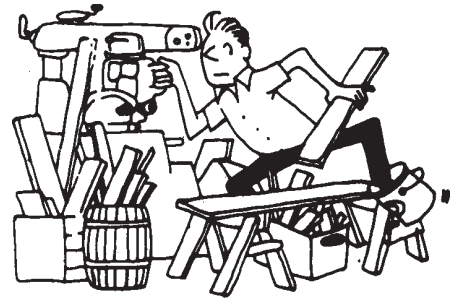

- **KEEP WORK AREA CLEAN.** Cluttered areas and benches invite accidents.

- **DON'T FORCE THE MACHINE.**

It will do a better and safer job at the rate for which it was designed.



- **DON'T OVERREACH.**

Keep your proper footing and balance at all times. For best footing, wear rubber soled footwear. Keep floor clear of oil, scrap wood, etc.



- **AVOID DANGEROUS ENVIRONMENTS**

Don't use power machines in damp or wet locations or expose them to rain.

Keep your work area well illuminated.

DO NOT USE in explosive atmosphere (around paint, flammable liquids etc.).



- **ENSURE THE WORKPIECE IS COMPLETELY SECURE** before switching ON.

NEVER hold a workpiece by hand alone.

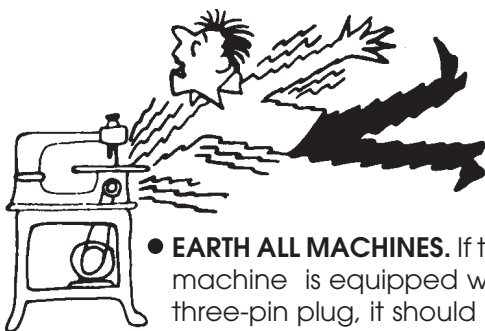

- **EARTH ALL MACHINES.** If the machine is equipped with three-pin plug, it should be plugged into a three-pin electrical socket. Never remove the earth pin.



- **ALWAYS WEAR SAFETY GOGGLES,**

manufactured to the latest European Safety Standards. Also use face or dust mask if cutting operation is dusty. Everyday eye glasses do not have impact resistant lenses, they are NOT safety glasses.



● **MAINTAIN MACHINE IN TOP CONDITION.**

Keep tools sharp and clean for the best and safest performance. Follow maintenance instructions.

● **ALWAYS ensure that ADEQUATE LIGHTING is available.** A minimum intensity of 300 lux should be provided. Ensure that lighting is placed so that you will not be working in your own shadow.

READ and BECOME FAMILIAR with the entire operating manual. Learn the machines applications and limitations as well as the specific potential hazards peculiar to it.

● **CHECK for DAMAGE.** Before using the machine, any damaged part, such as a guard etc., should be checked to ensure that it will operate properly, and perform its intended function. Check for alignment of moving parts, breakage of parts, mountings, and any other condition that may affect the machines' operation. Any damage should be properly repaired or the part replaced. If in doubt, DO NOT USE the machine. Consult your local dealer.

● **WEAR PROPER APPAREL.**

Loose clothing or jewellery may get caught in moving parts. Wear protective hair covering to contain long hair.



● **ALWAYS WEAR EAR PROTECTORS/DEFENDERS.** Considerable noise is generated by this type of equipment.

Ear protection should be used at all times

● **MAKE YOUR WORKSHOP CHILDPROOF.**

With padlocks, master switches where appropriate, or by removing starter keys etc.

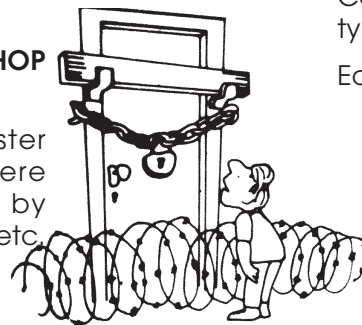

● **HANDLE WITH EXTREME CARE** Whenever transporting or installing machinery, and always use a lifting tool.

● **DRUGS, ALCOHOL, MEDICATION.** Do not operate machine while under the influence of drugs, alcohol or any medication.

● **ALWAYS KEEP GUARDS in place** and in working order.

● **NEVER STAND ON THE MACHINE.** Serious injury could occur if the machine is tipped or if a cutting tool is accidentally contacted. Do not store materials above or near a machine, such that it is necessary to stand on the machine to reach them.

● **USE ONLY RECOMMENDED ACCESSORIES.** The use of improper accessories could be hazardous.



AVOID ACCIDENTAL STARTING. Ensure the switch is OFF before plugging in to mains.

● **KEEP CHILDREN AWAY.**

All visitors should be kept a safe distance from the work area, especially whilst operating the machine.

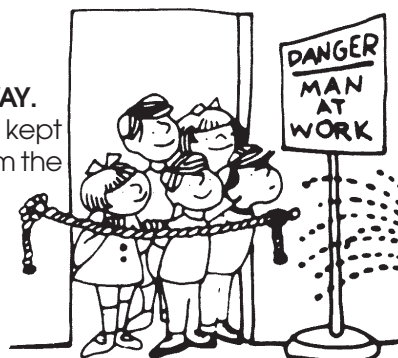

● **BE AWARE** that accidents are caused by carelessness due to familiarity. ALWAYS concentrate on the job in hand, no matter how trivial it may seem.

● **NEVER LEAVE MACHINE RUNNING UNATTENDED.** Turn power OFF. Do not leave machine until it comes to a complete stop

ADDITIONAL SAFETY PRECAUTIONS for TABLE SAWS

- Wear safety goggles as protection against flying wood chips and saw dust. In many cases, a full face shield is even better protection. A dust mask is also recommended to keep saw dust out of your lungs.
- Considerable noise is generated by this machine. Ear defenders should always be worn.
- Clear the work table of all objects (tools, scraps, rulers etc.), before turning on the saw.
- Keep your fingers well away from the blade, use a push stick as you near the end of the cut.
- Switch OFF the saw, and make sure the blade has come to a complete stop before clearing sawdust or off-cuts from the table.
- Make sure there are no nails or foreign objects in the part of the workpiece to be sawn.
- Set up the machine and make all adjustments with the power OFF, and disconnected from the supply.
- DO NOT operate the machine with the guards removed. They must all be in place and securely fastened when performing any operation.
- Use ONLY approved replacement saw blades. Contact your local CLARKE dealer for advice. The use of inferior blades may increase the risk of injury.
- DO NOT saw any material that does not have a flat surface on which to bear.
- This machine is designed for cutting wood. DO NOT use for cutting metal or plastic
- DO NOT attempt to cut round (tubular) work; i.e. logs etc.
- Do not feed the workpiece through the blade too fast, hold material firmly and feed into blade at a moderate speed.
- When cutting a large piece of material, support it at the height of the table, or use a table extension.
- Be extra cautious with very large or small, or irregularly shaped workpieces
- Never let go of a workpiece. Always maintain control.
- Never touch, or hold on to, a piece that has been cut off, whilst the power is ON, or the blade is rotating.
- Ensure the surface, on which the saw stands, is firm, solid and non-slip.

FEATURES

The Contractors Saw may be used for rip cutting or cross cutting timber up to 90mm (3½") in depth. The Table extension provides support for extra long pieces.

A double height Rip Fence is provided and may be secured at any desired position for quick and accurate rip sawing.

For speed and accuracy, a guide is also provided for cross cutting. It is adjustable so that mitres of up to 60° may be created.

The Upper Blade Guard is hinged to allow it to ride over the timber as the timber moves over the blade.

IMPORTANT:

The Blade Guard must always be in place.

The Lower Blade Guard comprises a box, on to which is mounted the motor and saw blade. A removable cover gives access to the blade and other components.

IMPORTANT:

This cover must always be in place and secure.

The box is secured by two large Lower Blade Guard Securing knobs. Slackening these knobs allows the complete box, with motor and blade, to move so that the blade may tilt by up to 45° - in one direction. It is then secured in position by tightening the same knobs.

Extending from the front end of the box is a handle, used for raising and lowering the blade and is explained under 'Operation'.

At the bottom of the box, a sawdust extraction outlet is provided. If required it can be connected to a dust extraction device which will provide fast and efficient removal of sawdust. The dust extractor may be used continuously or intermittently depending upon your requirements.

A pair of handles at the front end and a pair of wheels at the rear end allow the saw to be moved quickly and effortlessly around the workshop.

Construction of the table is in heavy, corrosion resistant, galvanised steel. The machine is nevertheless designed for indoor use. Should it be used outdoors, every attempt should be made to ensure it is protected from the elements. Do not use in wet conditions.

A push stick and push block are also provided.

THERMAL OVERLOAD

The machine is provided with a thermal overload device. Should the motor cut out during use, allow to cool for 5 - 10 minutes before switching ON again.

UNPACKING and PARTS IDENTIFICATION

Unpack the shipping carton, and lay out the components so that they can be clearly identified. Should there be any deficiencies, or damage suffered in transit, you should immediately contact your CLARKE dealer.

LOOSE PARTS

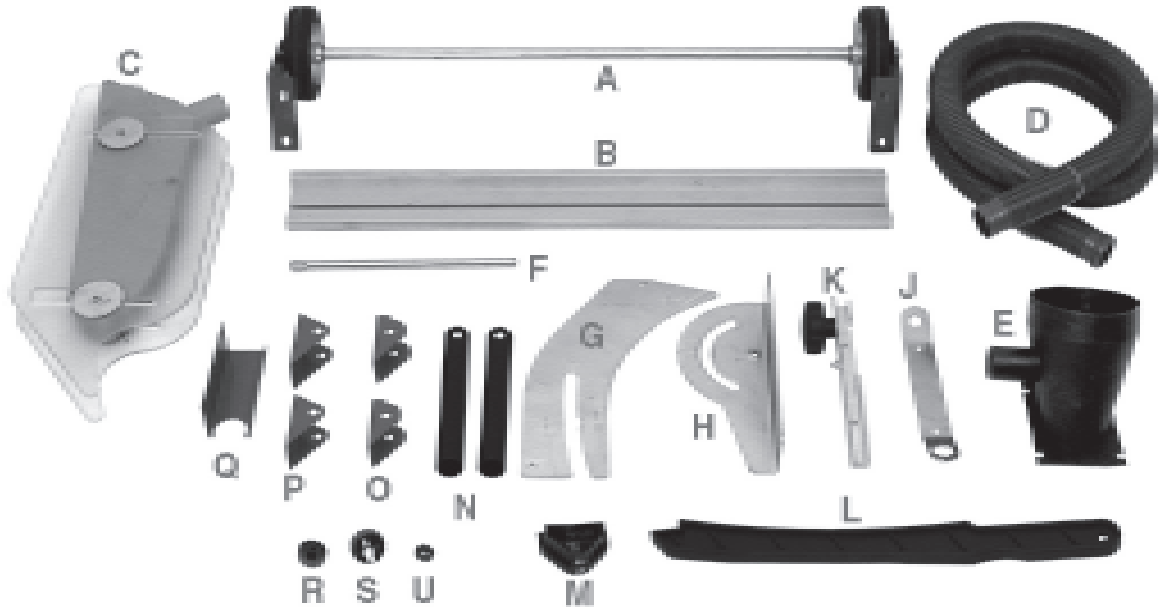

- A. Wheel and Axle Assy (1)
- B. RIP Fence (1)
- C. Upper Blade Guard Assy (1)
- D. Dust Extractor Hose (1)
- E. Dust Extractor Housing (1)
- F. Saw Blade Locking Bar (1)
- G. Riving Knife (1)
- H. Quadrant (1)
- J. Spanner (1)
- K. Rip Fence Support (1)
- L. Push Stick (1)
- M. Foot (4)
- N. Tubular Handle (2)
- O. Handle Bracket (2)
- P. Handle Bracket (2)
- Q. Dust Extractor Hose Bkt (1)
- R. End Cap for Knob Item S (2)
- S. Knob Assy, for Rip Fence Guide. (2)
- U. Rubber Washer (2)
- V. Leg (4)
- W. Table Extension Brace (2)
- X. Short Leg Brace (2)
- Y. Long Leg Brace (2)
- Z. Rip Fence/Mitre Gauge Guide (2)
- AA. Table Extension

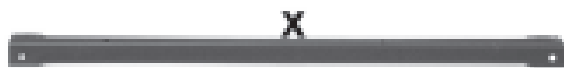
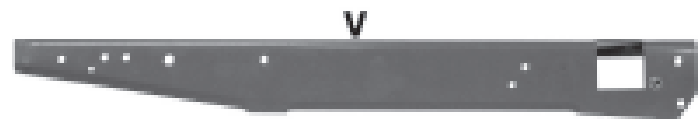
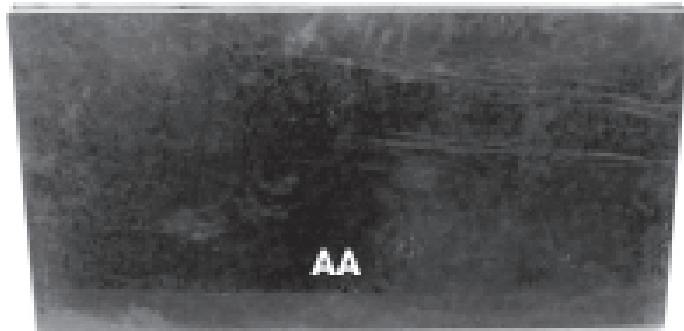

In addition to this lists of loose parts, bags containing all necessary fixings are also provided

PRINCIPAL PARTS

Fig.1

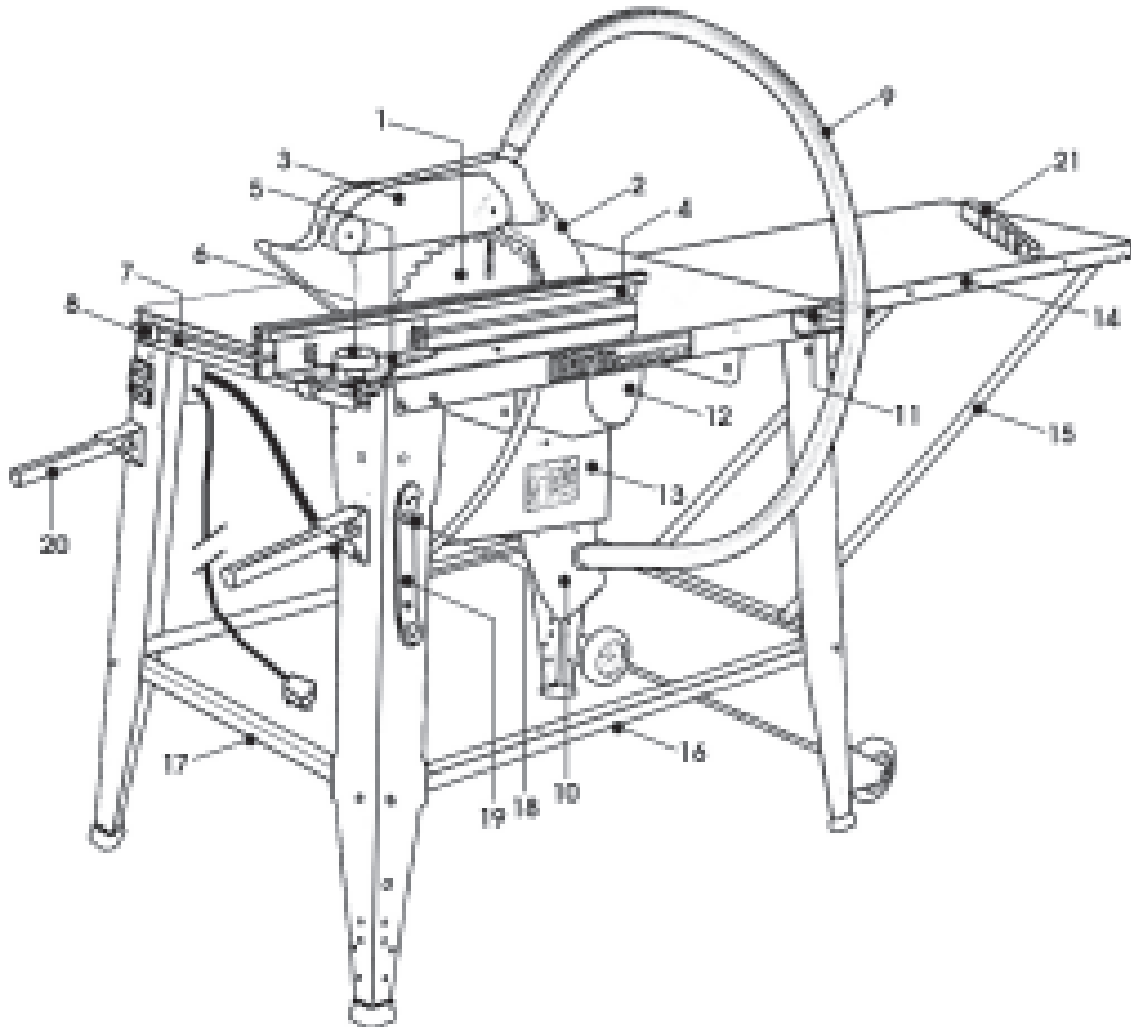

NOTE: The letters in brackets refer to the identification letters given in the illustrations on page 8

- | | |
|---------------------------------------|--------------------------------------|
| 1 - Saw Blade | 12 - Motor |
| 2 - Riving Knife (G) | 13 - Lower Blade Guard Box |
| 3 - Upper Blade Guard (C) | 14 - Table Extension (AA) |
| 4 - Rip Fence (B) | 15 - Table Extension Brace (Y) |
| 5 - Quadrant (H) | 16 - Long Leg Brace (W) |
| 6 - Rip Fence Support (K) | 17 - Short Leg Brace (X) |
| 7 - Rip Fence Guide (Z) | 18 - Hook for Spanner and Push Stick |
| 8 - Rip Fence Securing Knob (S) | 19 - Spanner (J) |
| 9 - Dust Extraction Hose (D) | 20 - Handle (N) |
| 10 - Dust Extractor Outlet (E) | 21 - Push Stick (L) |
| 11 - Dust Extraction Hose Bracket (Q) | |

ASSEMBLY

Unless otherwise specified, **DO NOT** fully tighten the fixing nuts during assembly. Due to the sharp edges associated with some of the components, it is advised that gloves be worn during the assembly process.

A. Legs and Braces

1. With assistance, turn the table assembly over on to its table top, resting it on a piece of cardboard. The saw blade is fully retracted for transit purposes.
2. Bolt a leg, loosely to each corner, ensuring the leg with the hole, to accommodate the ON/OFF switch box, is located at the left hand front corner, as shown in Fig.2. A flat washer should be used with the self locking nuts provided

Note: The legs are numbered....make sure the numbers correspond with the numbers at each of the four corners of the table top.

3. Attach the two, long leg Braces, with the broad face downwards (facing the table) and open angle facing the feet, and the two shorter leg Braces, in a similar manner.

NOTE: All nuts are self locking, and should be run up with a spanner until they just begin to tighten. Do not fully tighten at this stage.

4. Attach the four plastic feet, ensuring they are pushed home fully.

B. Switch Box

5. Attach the STOP/START switch box to the left hand leg, using two self tapping screws provided, (arrowed in Fig.3).

C. Wheel Assembly

6. Attach the wheel assembly in the manner shown in Fig. 4, using the M6 nuts, screws and flat washers provided.

Fig.2

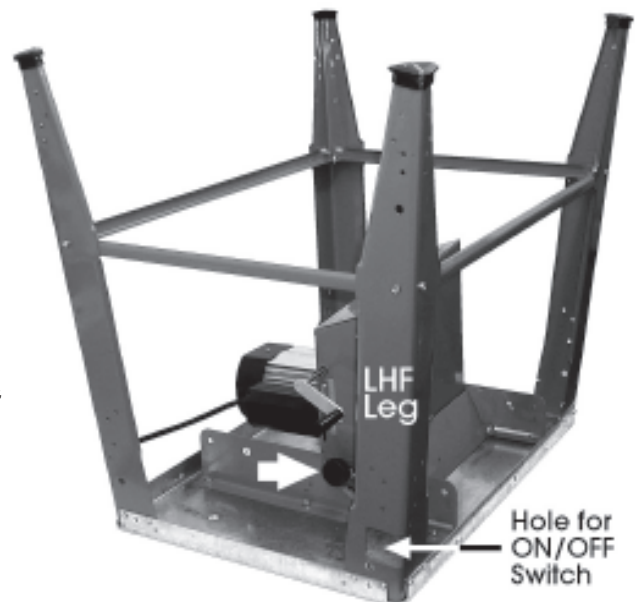

Fig.3

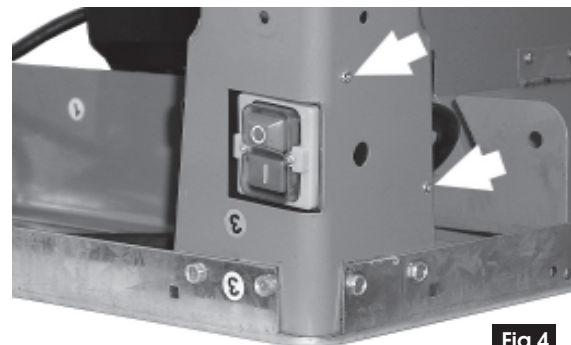

Fig.4



D. Table Extension

7. Lay the table extension face down and adjoining the table top in the manner shown in Fig. 5.
8. Remove the two screws previously entered to secure the leg to the table top, then bolt the table extension to the table top using the same nuts, washers and screws, and a third screw for the third mounting as shown.
9. Attach the two Braces, one end to the short leg brace, the other to the table extension, noting that the angles formed on the ends of the Braces are different at each end. Ensure therefore that they lie in the correct plane at each end before securing using the M6 nuts bolts and washers provided.

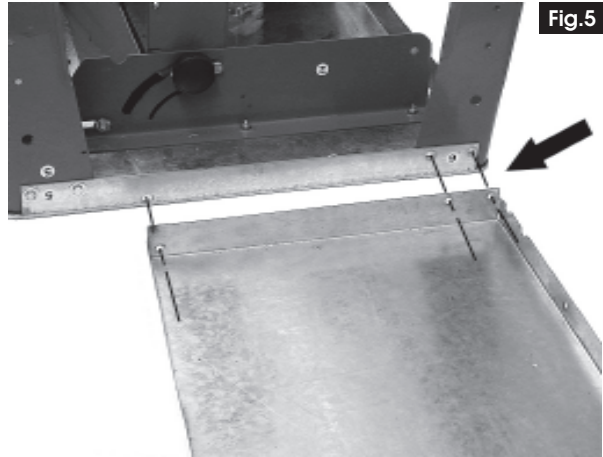

Fig.5

E. Dust Extraction Outlet

10. Attach the Dust Extraction Outlet to the underside of the lower blade guard box, as shown in Fig. 6.



Fig.6

At this point, using assistance, turn the assembly on to its feet. Ensure you tighten the two lower blade guard securing knobs, one of which is arrowed in Fig. 2, beforehand.

11. With the assembly resting firmly on its feet, shake it vigorously and once it is stable, proceed to tighten all fixing nuts securely.
Ensure the table extension top and the table top lie in the same plane before securing the fixing bolts.

F. The Riving Knife

12. Remove the Table insert, secured with 6 screws, then raise the saw blade fully, by turning the handle on the end of the lower blade guard box (see Fig.17, p 16).
13. Undo the clamping nut, arrowed in Fig. 7, sufficient for the riving knife to be slipped between the two halves of the clamp, with the curved slot of the riving knife sliding over the clamping bolt.

Run up the clamping nut ensuring the raised bosses on the inside faces of the clamp halves are located in the curved slot of the riving knife.

Before fully tightening the clamping nut, adjust the riving knife so that a gap of 3-8mm maximum, exists between the knife and the tips of the saw blade teeth, for the full length of the riving knife...see Fig 8, p. 12.

When satisfied, tighten the clamping nut and replace the Table Insert.

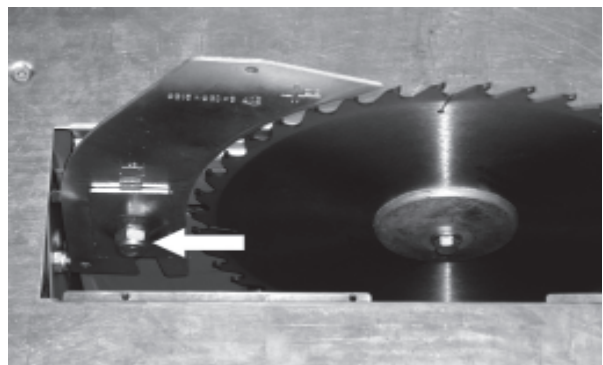
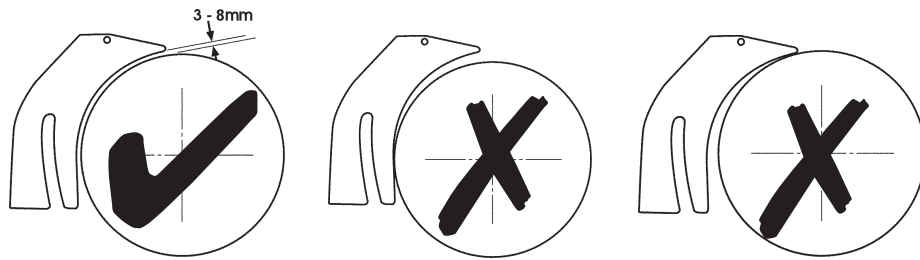

Fig.7

Fig.8



IMPORTANT!

The Riving Knife **MUST** be completely in-line with the saw blade. Should it not be so, having followed these assembly instructions, adjustments are necessary, which are described on page 19.

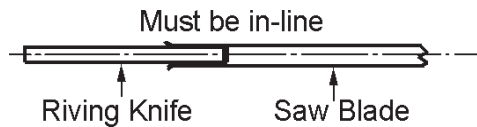

IMPORTANT: The Riving Knife must ALWAYS be in place and in good condition

G. Upper Blade Guard & Fittings

14. Remove the Pivot bolt from the Upper Blade Guard, then secure the Upper Blade Guard to the Riving Knife using the same bolt, screwed into the nut held in a recess in the blade guard. The nut and end of the bolt is arrowed in Fig.9.

Fig.9



WARNING!
The Upper Blade Guard must ALWAYS be in place and in good condition. If it is damaged in any way, have it repaired or replaced.

Fig.10

15. Bolt the Dust Extractor Hose bracket to the right hand rear of the table top, as shown in Fig. 10, and attach the hose to the upper blade guard at one end, and the dust extractor outlet on the lower blade guard at the other.



H. Rip Fence Guide

16. Fit the Rip Fence Guide to the front end of the table using the screws, rubber washers, flat washers and nuts provided in the manner shown in Fig. 11.

Tighten the nuts firmly in order to squeeze the rubber washer tightly..but do not over tighten.

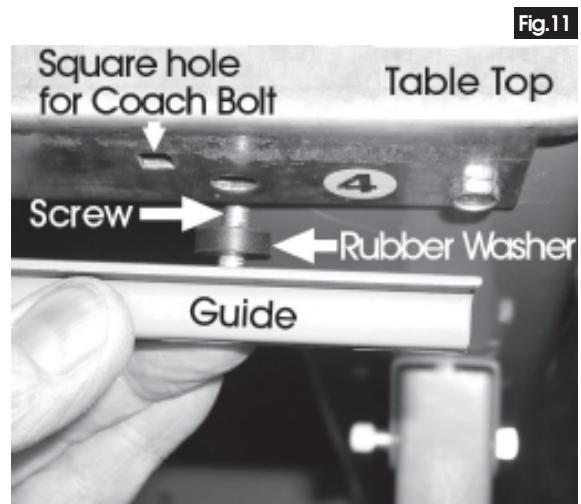

17. Insert the square shanked coach bolt through the square hole in the table top, (see Fig.11) then through the Rip Fence Guide.

Press a nut into the hex. depression within the Clamping Knob, and then thread the nut, with the knob, on to the coach bolt, (as shown in Fig. 12), until it becomes firm,

Finally press the Clamping Knob End Cover securely into place to obscure the nut and screw.



Note: The rubber washers allow slight movement of the Guide, so that when the two clamping knobs are tightened the rip fence support is clamped firmly between the table and the guide, preventing lateral movement.

This is illustrated in Fig.17, p16

I. Cross Cut Guide

18. The Cross Cut Guide is attached simply by bolting the guide to the table top using two M6 bolts, flat washers and nuts provided as shown in Fig. 13.

NOTE: It will be necessary to remove those bolts already fitted to secure the leg to the table top.

Tighten the nuts fully. You will note that an open channel is formed between the table and the guide. This is to allow the Rip Fence assembly to slide smoothly for the length of the guide (see Cross Cutting).

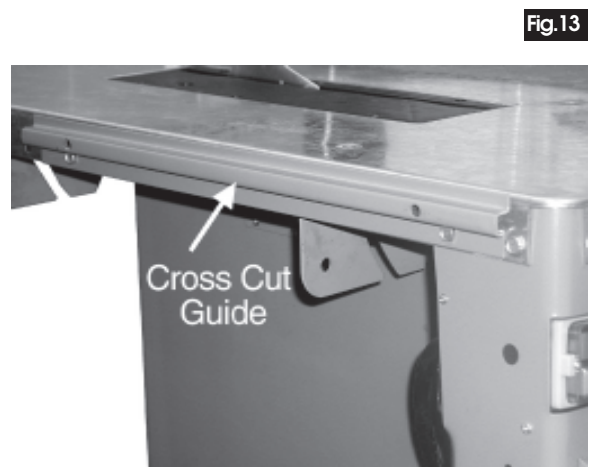

J. Rip Fence

NOTE: The Rip Fence may be used in either high or low position. Fig14 illustrates the fence assembled in the high position with the work bearing against face 'A'.

Assembly is as follows:

19. Slide the large screws (C) into the channel in the rip fence as indicated, then mount the Quadrant (D), on these screws, and secure using the wing nuts provided.

NOTE: If the screws 'C' are entered in the channel 'G', then the rip fence will be at its LOW position with the work bearing against face 'B'.

20. Attach the Rip Fence Support (E) to the underside of the quadrant, as shown, so that the post on the support protrudes through the hole in the quadrant, and secure using the knob head screw (H) and flat washer provided.

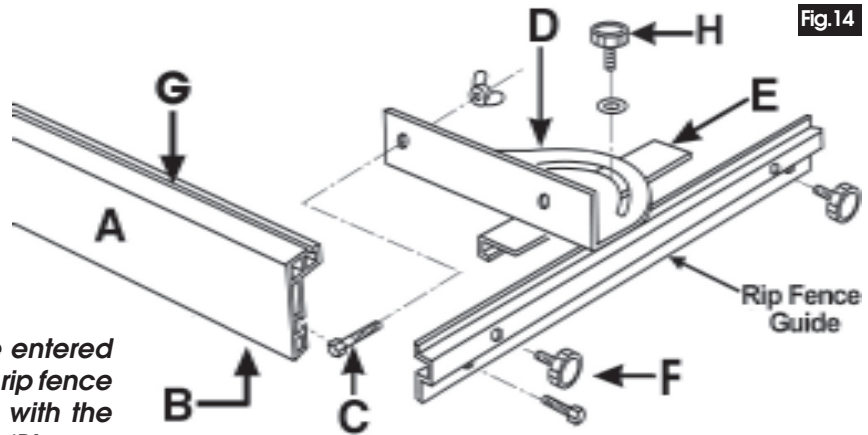

K. Handles

21. Bolt the outer brackets to the legs at the front of the machine, in the manner shown in Fig. 15a.



Fig.15a



Fig.15b



Fig.15c

22. Position the inner bracket as shown in Fig 15b, then insert the handle and align the holes in the brackets and handle before inserting the bolt...Fig. 15C. Screw on the self locking nut and tighten, ensuring the handles are free to raise and lower smoothly.

L. Tool Hook

23. A square hook is provided on which to hang the spanner and push stick. The hook is entered into the hole on the side of the right hand front leg, and the locking nut tightened. The hook is indicated in Fig. 1 page 9 and shown in Fig. 16

Fig.16



Your Contractors Saw is now fully assembled. Before use however, it is important to ensure that all electrical connections and various adjustments are correctly made in accordance with the instructions which follow

ELECTRICAL CONNECTIONS

This appliance is fitted with a standard, 230 Volt (50Hz) BS 1363 approved 13 amp plug, for connection to a standard domestic 13 Amp electrical supply. We strongly recommend that connection be via a Residual Current Device (RCD).

WARNING! THIS APPLIANCE MUST BE EARTHED

IMPORTANT: Should the plug be replaced, it is important to note that the wires in the mains lead are coloured in accordance with the following code

Green & Yellow Earth
Blue Neutral
Brown Live

As the colours of the flexible lead of this appliance may not correspond with the coloured markings identifying terminals in your plug proceed as follows:

- Connect GREEN & YELLOW coloured cord to plug terminal marked with a letter "E" or Earth symbol "⏏" or coloured GREEN or GREEN & YELLOW.
- Connect BROWN coloured cord to plug terminal marked with a letter "L" or coloured RED.
- Connect BLUE coloured cord to plug terminal marked with a letter "N" or coloured BLACK.

If this appliance is fitted with a plug which is moulded onto the electric cable (i.e. non-rewirable) please note:

1. The plug must be thrown away if it is cut from the electric cable. There is a danger of electric shock if it is subsequently inserted into a socket outlet.
2. Never use the plug without the fuse cover fitted.
3. Should you wish to replace a detachable fuse carrier, ensure that the correct replacement is used (as indicated by marking or colour code).

Fuse Rating

The fuse in the plug must be replaced with one of the same rating (13 amps) and this replacement must be ASTA approved to BS1362.

IMPORTANT:

If a cable extension is needed, it is essential to comply with the following data.

Voltage	Extension length	Cable section
230v	Up to 20m	2.5mm ²
230v	From 20 to 50m	4mm ²

ADJUSTMENTS

Before carrying out any adjustments, ensure the machine is disconnected from the electrical supply

For normal ripping or cross cutting, The blade should be exactly perpendicular to the table. To check and adjust, you should proceed as follows:

1. Raise the blade to its maximum height by using the handle mounted on the front of the Lower Blade Guard box, shown in Fig. 17.
2. Place a small square on the table, and slide it up to the blade, checking to ensure the blade is perpendicular.
3. If adjustment is required, slacken off both Blade Guard Securing Knobs, (the front knob is shown in Fig. 17 at 'A'), allowing the box to be moved so that the blade is correctly aligned. Finally, re-tighten the adjuster knobs.

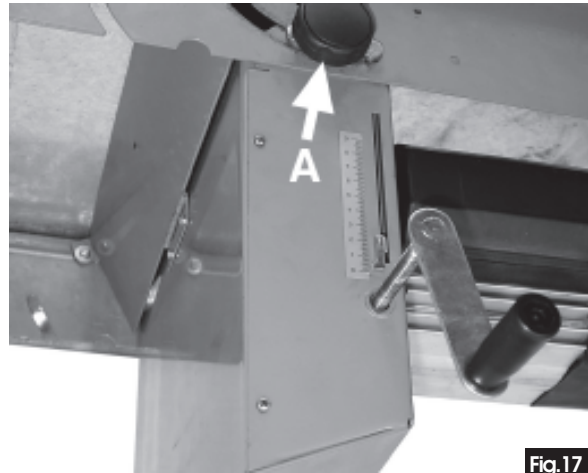

Fig.17

NOTE: Both blade height and angle indicators are provided, but as these are fixed position, they should not be relied upon for absolute accuracy. You should always check blade height with a gauge/steel rule etc., or the blade angle with a protractor/template etc., where absolute accuracy is desired.

FINAL CHECKS BEFORE USE

IMPORTANT.

ALWAYS carry out the following checks BEFORE use, i.e. BEFORE connecting the machine to the mains supply.

- A.** The Riving Knife is essential in preventing kickback, and hence the risk of personal injury, and producing a good clean cut without chattering or binding taking place.

Before use, check to ensure it is straight and directly in line with the blade, with the correct clearance of 3 - 8mm maintained along its full length (see fig. 8 on page 12).

Should the Riving Knife become out of shape or misaligned, it must be gently eased back into line, or if the damage is more severe, it must be removed and bent back into shape accordingly or replaced. Riving Knife adjustment is described on page 11.
- B.** Check to ensure the blade teeth are sharp and the blade is sound. If teeth are chipped, or cracks are apparent, the blade must be renewed.
- C.** Always check to ensure that the Lower Blade Guard Box and the Lower Blade Guard Box Cover are firmly secured.
- D.** Ensure the Upper Blade Guard is in place, pivots freely, and falls under its own weight.
- E.** Check the power cable to ensure it is in perfect condition before connecting to the power supply. If it is damaged in any way, have it renewed.

WARNING

*This machine is NOT designed for non-through cutting.
The Upper Blade Guard MUST be in place at all times.*

OPERATION

1. RIP CUTTING

You should always set the depth of the blade, to the thickness of the wood plus 2mm. i.e. the blade should only just break the surface of the wood. This is to obtain maximum efficiency, and to protect and preserve the saw blade teeth, particularly when cutting thin sections.

Blade depth is set by raising or lowering the blade, using the handle shown in Fig. 17.

True, straight line rip cutting, is best done by guiding the work against the rip fence. Check to ensure the Rip Fence is mounted correctly and is parallel to the blade, as follows:

1.1 Mounting the Rip Fence

Slacken the two guide clamping knobs, sufficient for the rip fence support to be slipped between the guide and the table, as shown in Fig. 18.



1.2 Ensuring Rip Fence is Parallel to Blade

Lock the fence to the table, approx. 9" or so from the blade by tightening the two clamping knobs.

Measure the distance from the side of the blade to the rip fence, **at the front AND the rear of the blade**. The two measurements should be equal. If they are not, then the fence is not parallel to the blade. If this is the case, slacken the knob securing the fence to the quadrant, make the necessary adjustment until the measurements are equal, then re-tighten the knob. The Rip Fence is now parallel to the blade.

Move the Rip Fence the required distance from the blade, and clamp securely, then, having taken all the necessary precautions previously stated, switch ON the machine by pushing the green start button, marked 'I', and proceed to feed the work into the blade.

- Do not force the work, a gentle pressure is all that is required.
- The feed force should **ALWAYS** be applied between the saw blade and the fence, and down on to the table, NOT on the section that will become the cut-off piece.
- Always use a push stick when the end of the work approaches the blade, or for short work or work less than 6" wide.
- **NEVER** hold on to the free piece that is cut off, it is important that it is not constrained in any way. It must be allowed to move laterally.
- Longer workpieces should be adequately supported. Roller Supports, ideal for this purpose, are available from your Clarke dealer

When switching OFF, by pushing the red stop button marked 'O', the blade should stop within 8-10 seconds.

2. CROSS CUTTING.

Attach the rip fence assembly to the cross cut guide ensuring it moves smoothly along the guide. Adjust the fence to the required angle using the quadrant, then, holding the workpiece firmly against the fence, proceed to feed it into the saw blade by sliding the fence along the table. Fig. 19 illustrates the setup for cutting a 45 degree mitre.

Take care to ensure the rip fence cannot come into contact with the saw blade as it is moved along the guide. Slacken the wing nuts and reposition if necessary.

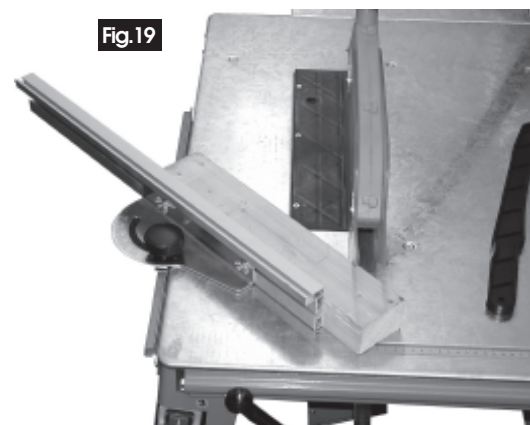

- **NEVER** use a 'length stop' on the free end of the workpiece.
- **NEVER** touch or hold on to the free piece whilst the saw blade is rotating. This means that, when feeding the workpiece through, you should NOT hold on to it on either side of the blade.
Remember, the free piece should not be constrained in any way. It must be allowed to move laterally.
- Long pieces of work must be supported at table height, and the workpiece must be free to move easily. It is advised to use an assistant for very long pieces. Roller Supports, ideal for this purpose, are available from your Clarke dealer

3. BEVEL CUTTING

Set the blade angle using a suitable template, by slackening off the two lower blade guard securing knobs (see Fig. 17) and positioning the blade accordingly. Ensure the securing knobs are perfectly tight before proceeding.

MAINTENANCE

1. GENERAL

Maintenance is limited to, changing the saw blade when necessary, maintaining adjustments, and ensuring that after use, any sawdust or wood chips are cleaned away using a low pressure air line or brush.

2. THE SAW BLADE

WARNING

1. *ALWAYS disconnect the machine from the power source before performing any maintenance tasks*
2. *Take great care when handling the saw blade. Blade teeth are extremely sharp, and carelessness could cause severe injury.*

A. Blade Removal

1. Remove the Upper Blade Guard - single mounting bolt.
2. Remove the Table Insert - 6 screws.
3. Raise the saw blade to its maximum height.
4. Carefully rotate the blade until the hole provided in the drive shaft lines up with the hole in the table top, then insert the bar provided to lock the shaft (see Fig. 20).
5. Holding the locking bar, unscrew the saw blade centre bolt using the spanner provided, noting it has a **LEFT HAND THREAD**, i.e. turn it **CLOCKWISE** to undo, then pull off the Outer Flange followed by the saw blade.

Fig.20

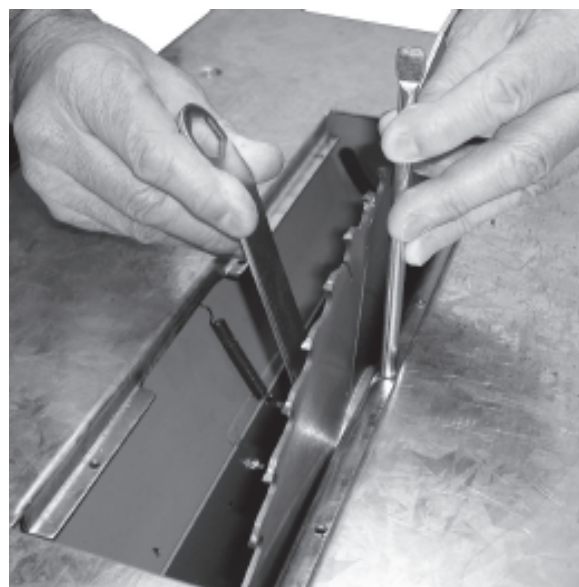

B. Blade Replacement

1. Slacken the clamping, bolt securing the riving knife, and move the knife sufficiently for the new blade to be installed.
2. Taking great care to avoid damaging your hands on the sharp teeth, slide the blade through the blade slot and on to the shoulder of the inner flange, ensuring it is the correct way round. i.e. the teeth are facing down at the front of the table, or up at the riving knife.
3. Locate the Outer Flange on the drive shaft ensuring the lugs on the inner flange locate correctly in the slots provided in the outer flange.
4. Replace the Centre Bolt and tighten remembering to tighten it**ANTICLOCKWISE**.
5. With the saw blade in place, the Riving Knife **must** be adjusted to ensure the correct clearance is set between it and the saw blade. It is important that this adjustment is maintained at all times and must be checked regularly. This procedure is described on page 11.

3. RIVING KNIFE ALIGNMENT

It is most important that the Riving Knife is directly in line with the Saw Blade at all times, (see pages 11 and 12).

In order for it to be correctly aligned, it may be necessary for it to be moved 'outwards', away from its mounting bracket slightly. For this purpose, two 1mm shims are provided and should be fitted as follows:

NOTE: One or both of the shims may be used as required.

1. Undo and remove the clamping nut completely.
2. Remove Outer Clamp, Riving Knife and Location Plate.
3. Slide the appropriate shim on to the coach bolt, followed by the Location plate and hold in place, ensuring the holes in the shim, locate on the inner lugs on the Location Plate.

NOTE: The shims are identical....one fits between the Backplate and the Location Plate, the other, if required, between the Location Plate and Riving Knife.

DO NOT place the two shims together....if two are required, they MUST be positioned on either side of the Location Plate

4. If required, slide on the second shim, and hold in place ensuring the holes locate on the lugs of the Location Plate, then slide on the Riving Knife, followed by the Outer Clamp and Clamping Nut. Spin up the nut, ensuring the shims remain in place, and, before tightening fully, adjust the Riving Knife so that it is the correct distance from the saw blade as illustrated on page 12.
5. Check the position of the Riving Knife. If necessary, add the second shim (if not already fitted, or remove....as required).

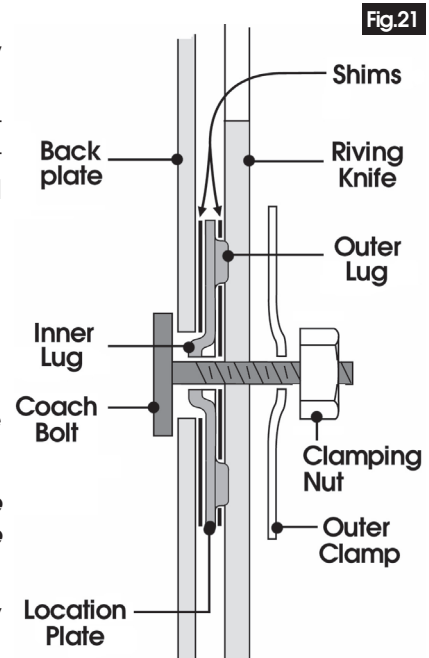

PARTS LIST

No.	Description	Part No.	No.	Description	Part No.
1	Lower blade Guard Box	TMCCS1201	44	Blade Angle scale	TMCCS1244
2	Motor Guidance Plate	TMCCS1202	45	Blade Height Scale	TMCCS1245
3	Plate Lever	TMCCS1203	47	Coach Bolt	TMCCS1247
4	Guidance Frame	TMCCS1204	48	C'sk Screw	TMCCS1248
5	Crank Complete	TMCCS1205	49	Flat Washer	TMCCS1249
6	Crank Handle	TMCCS1206	50	Flat Washer	TMCCS1250
7	Pointer	TMCCS1207	51	Hex. Screw M8x16	TMCCS1251
8	Table	TMCCS1208	52	Hex. Screw M8x25	TMCCS1252
9	Support Plate Front	TMCCS1209	53	Self Locking Nut M8	TMCCS1253
10	Support Plate Rear	TMCCS1210	54	Nut M8	TMCCS1254
11	Securing Knob	TMCCS1211	55	Washer	TMCCS1255
12	Motor Complete	TMCCS1212	56	Washer	TMCCS1256
13	Switch c/w Cable	TMCCS1213	57	Nut M10	TMCCS1257
14	Screw M6	TMCCS1214	59	Cylinder Screw	TMCCS1259
15	Table Leg LHF	TMCCS1215	60	Self Locking Nut M5	TMCCS1260
17	Table Leg RHF	TMCCS1217	61	Wing Nut M6	TMCCS1261
18	Table Extension	TMCCS1218	62	Hex. Screw M10x25	TMCCS1262
19	Leg Brace Long	TMCCS1219	64	Self Locking Nut M6	TMCCS1264
20	Leg Brace Short	TMCCS1220	65	Screw M6x45	TMCCS1265
21	Table Extension Brace	TMCCS1221	66	Spring Ring	TMCCS1266
22	Guide	TMCCS1222	67	Table Top Scale	TMCCS1267
23	Rubber Washer	TMCCS1223	68	Shim	TMCCS1268
24	Nut M6	TMCCS1224	69	Screw M5	TMCCS1269
25	Foot	TMCCS1225	70	Spring Washer	TMCCS1270
26	Sawdust Extractor Outlet	TMCCS1226	71	Brake	TMCCS1271
27	Hinged Plate	TMCCS1227	72	Spring	TMCCS1272
28	Front Panel	TMCCS1228	73	Screw M5x40	TMCCS1273
29	Inner Flange	TMCCS1229	74	Flat Washer	TMCCS1274
30	Outer Flange	TMCCS1230	75	Screw M516	TMCCS1275
31	Riving Knife	TMCCS1231	76	Nut M5	TMCCS1276
32	Table Insert	TMCCS1232	77	Side Guard	TMCCS1277
33	Upper Blade Guard	TMCCS1233	78	Wheel Assembly	TMCCS1278
34	Rip Fence Support	TMCCS1234	79	Supporting plate	TMCCS1279
35	Quadrant	TMCCS1235	80	Self Locking Nut M10	TMCCS1280
37	Rip Fence	TMCCS1237	81	Rubber Washer	TMCCS1281
38	Saw Blade	See Accessories	82	Spring	TMCCS1282
39	Clamping Plate	TMCCS1239	83	Table Leg	TMCCS1283
40	Pressure Plate	TMCCS1240	84	C'sk Screw M5	TMCCS1284
41	Push Stick	TMCCS1241	-	Dust Extraction Hose	TMCCS1285
42	Self Tapping Screw	TMCCS1242	-	Tool Hook	TMCCS1286
43	Hex. Screw M6x16	TMCCS1243	-	Trailing Socket	TMCCS1287

PARTS DIAGRAM

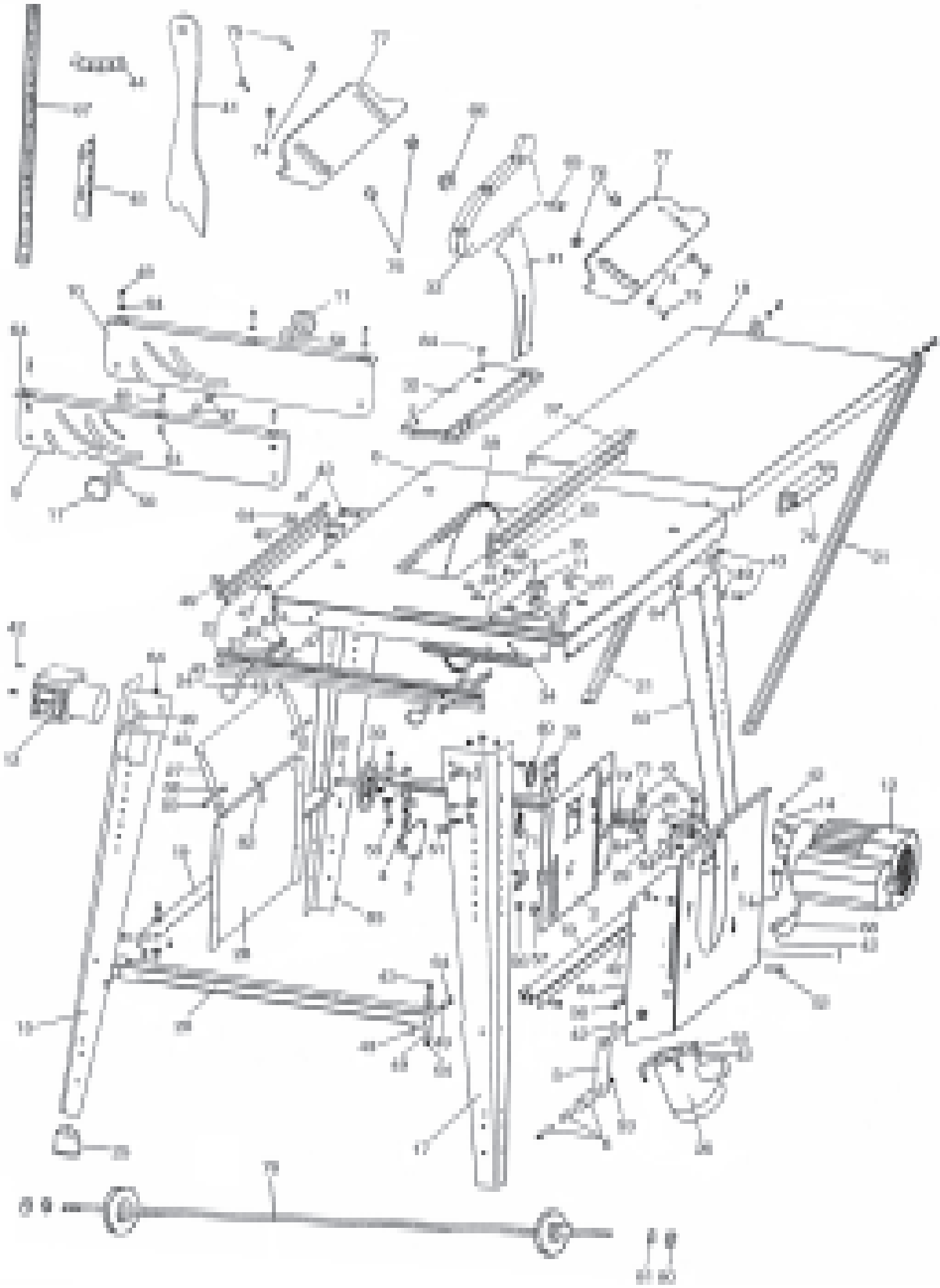

SPECIFICATIONS

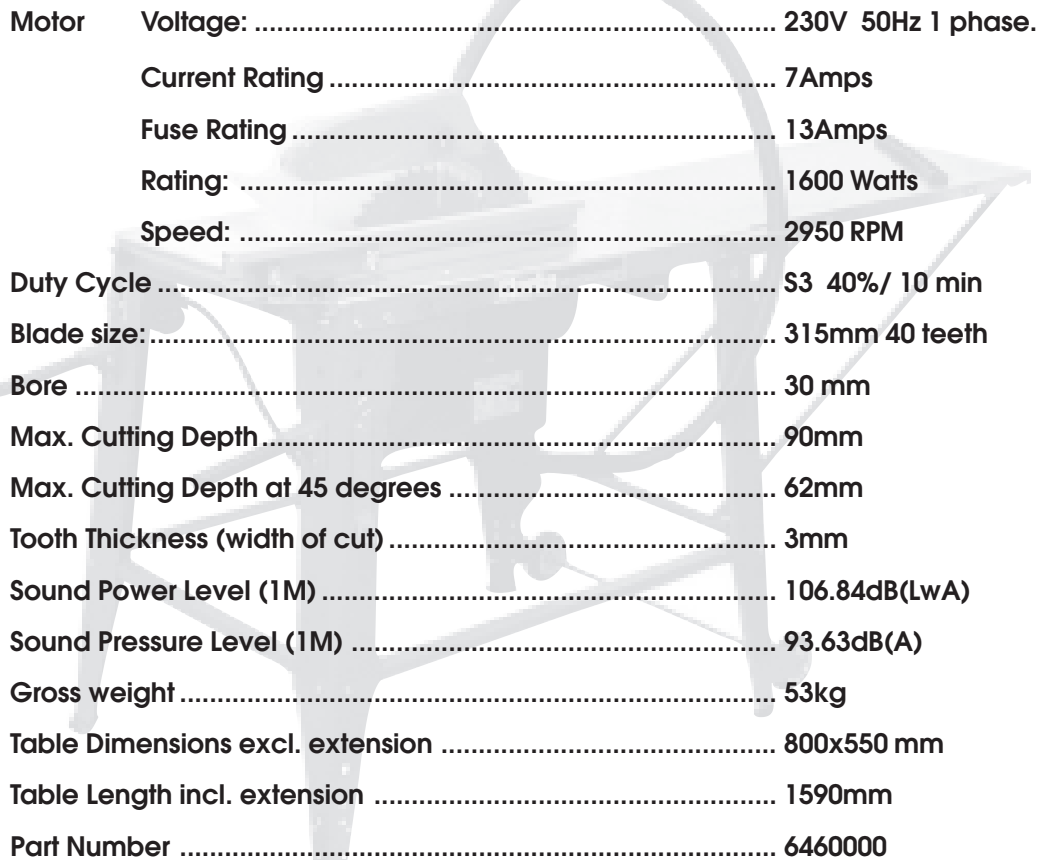

Motor	Voltage:	230V 50Hz 1 phase.
	Current Rating	7Amps
	Fuse Rating	13Amps
	Rating:	1600 Watts
	Speed:	2950 RPM
Duty Cycle	S3 40%/ 10 min	
Blade size:	315mm 40 teeth	
Bore	30 mm	
Max. Cutting Depth	90mm	
Max. Cutting Depth at 45 degrees	62mm	
Tooth Thickness (width of cut)	3mm	
Sound Power Level (1M)	106.84dB(LwA)	
Sound Pressure Level (1M)	93.63dB(A)	
Gross weight	53kg	
Table Dimensions excl. extension	800x550 mm	
Table Length incl. extension	1590mm	
Part Number	6460000	

Please note that the details and specifications contained herein, are correct at the time of going to print. However, CLARKE International reserve the right to change specifications at any time without prior notice.
Always consult the machine's data plate

ACCESSORIES

1. Saw Blade TCT 40 Teeth Part No. 6490170
2. Saw Blade TCT 60 Teeth Part No. 6490180

PARTS & SERVICE CONTACTS

For Spare Parts and Service, please contact your nearest dealer, or CLARKE International, on one of the following numbers.

PARTS & SERVICE TEL: 020 8988 7400

PARTS & SERVICE FAX: 020 8558 3622

or e-mail as follows:

PARTS: Parts@clarkeinternational.com

SERVICE: Service@clarkeinternational.com

Clarke[™]
INTERNATIONAL

This is an important document, and should be retained.

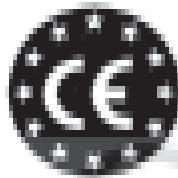

DECLARATION OF CONFORMITY

We declare that this product complies to the following standards/directives:

■ **90/37/EC**

CERTIFICATE No. RM2010790 01

REPORT No. P9907086 E 01

Issued in conjunction with TÜV Rheinland Product Safety GmbH, Am Grauen Stein, D-51105, Köln
License No. 82057251

Product Description: 12' (305mm) Contractors Saw

Model Number: OCS12

Serial (Batch) No: See Front Cover

Signed

Clarke INTERNATIONAL

General Wood, Topping, Saw (M14-40)

This declaration is a binding type of Clarke International product