

Charmer®



WARNING: Read these instructions before using the machine

CORDLESS ROTARY TOOL KIT MODEL NO: CCRT266

PART NO: 6461901

OPERATION & MAINTENANCE INSTRUCTIONS



LS1016

INTRODUCTION

Thank you for purchasing this cordless rotary tool kit.

Please read this manual thoroughly, before attempting to operate, and carefully follow all instructions given.

It is vitally important that ALL precautions are taken, as specified, which will not only provide protection for yourself and that of others around you, but will also ensure that the product will give you long and satisfactory service.

GUARANTEE

This CLARKE product is guaranteed against faulty manufacture for a period of 12 months from the date of purchase. Please keep your receipt as proof of purchase.

This guarantee is invalid if the product is found to have been abused or tampered with in any way, or not used for the purpose for which it was intended.

Faulty goods should be returned to their place of purchase, no product can be returned to us without prior permission.

This guarantee does not effect your statutory rights.

SPECIFICATIONS

Operating Voltage:	9.6 V-DC
Battery charge time	3 Hours
No-Load Speed	5000-25000 rpm
Collet Capacity	1 x 1/16" 1 x 3/32" 2 x 1/8" (3.175 mm)
Sound Pressure Level LpA	80 dB
Sound Power Level LWA	91 dB
Vibration	Less than 2.6 m/s ²
Dimensions (L x W x H)	225 x 53 x 46 mm
Weight (kg)	1.7 kg
Part Number	6461901

SAFETY PRECAUTIONS



WARNING: READ ALL INSTRUCTIONS. FAILURE TO FOLLOW ALL INSTRUCTIONS LISTED BELOW MAY RESULT IN ELECTRIC SHOCK, FIRE AND/OR SERIOUS INJURY. THE TERM "POWER TOOL" IN ALL WARNINGS LISTED BELOW REFERS TO YOUR BATTERY OPERATED (CORDLESS) POWER TOOL.

WORK AREA

1. **Keep work area clean and well lit.** *Cluttered and dark areas invite accidents.*
2. **Do not operate power tools in explosive atmospheres, such as in the presence of flammable liquids, gases or dust.** *Power tools create sparks which may ignite the dust or fumes.*
3. **Keep children and bystanders away while operating a power tool.** *Distractions can cause you to lose control.*

ELECTRICAL SAFETY

1. **Avoid body contact with earthed or grounded surfaces such as pipes, radiators, ranges or refrigerators.** *There is an increased risk of electric shock if your body is earthed or grounded.*
2. **Do not expose power tools to rain or wet conditions.** *Water entering a power tool will increase the risk of electric shock.*
3. **When operating a power tool outdoors, use an extension cord suitable for outdoor use.** *Use of a cord suitable for outdoor use reduces the risk of electric shock.*

PERSONAL SAFETY

1. **Stay alert, watch what you are doing and use common sense when operating a power tool. Do not use a power tool while you are tired or under the influence of drugs, alcohol or medication.** *A moment of inattention while operating power tools may result in personal injury.*
2. **Use safety equipment. Always wear eye protection.** *Safety equipment such as dust mask, non-skid safety shoes, or hearing protection used for appropriate conditions will reduce personal injuries.*
3. **Avoid accidental starting. Ensure the switch is in the off position before inserting the battery.**
4. **Remove any adjusting key or wrench before turning the power tool on.** *A wrench or a key left attached to a rotating part of the power tool may result in personal injury.*

5. **Do not overreach. Keep proper footing and balance at all times.** *This enables better control of the power tool in unexpected situations.*
6. **Dress properly. Do not wear loose clothing or jewellery. Keep your hair, clothing and gloves away from moving parts.** *Loose clothes, jewellery or long hair can be caught in moving parts.*

POWER TOOL USE AND CARE

1. **Do not force the power tool. Use the correct power tool for your application.** *The correct power tool will do the job better and safer at the rate which it was designed.*
2. **Do not use the power tool if the switch does not turn it on and off.** *Any power tool that cannot be controlled with the switch is dangerous and must be repaired.*
3. **Disconnect the battery before making any adjustments, changing accessories, or storing power tools.** *Such preventive safety measures reduce the risk of starting the power tool accidentally.*
4. **Store idle tools out of the reach of children and do not allow persons unfamiliar with the power tool or these instructions to operate the power tool.** *Power tools are dangerous in the hands of untrained users.*
5. **Maintain power tools. Check for misalignment or binding of moving parts, breakage of parts and any other condition that may affect the power tools operation. If damaged, have the power tool repaired before use.** *Many accidents are caused by poorly maintained power tools.*
6. **Keep cutting tools sharp and clean.** *Poorly maintained cutting tools with sharp cutting edges are less likely to bind and are easier to control.*
7. **Use the power tool, accessories and tool bits etc., in accordance with these instructions and in the manner intended for the particular type of power tool, taking into account the working conditions and the work to be performed.** *Use of the power tool for operations different from intended could result in a hazardous situation.*

SERVICE

1. **Have your power tool serviced by a qualified repair person using only identical replacement parts.** *This will ensure that the safety of the power tool is maintained.*

ADDITIONAL SAFETY INSTRUCTIONS FOR ROTARY TOOLS

1. Only use accessories supplied for use with this tool.
2. Never use worn or cracked accessories.
3. Hold the tool away from your face when switching on.
4. Keep your fingers away from rotating accessories.
5. Be careful not to accidentally hit any foreign objects in the workpiece.
6. If an accessory jams, switch the tool off and disconnect the battery before attempting to free the accessory.
7. Clamp the workpiece whenever possible especially when using cutting discs.
8. Always wear a dust mask and eye protection.
9. Thoroughly remove all dust after sanding.
10. **Take special care when sanding paint which is possibly lead based or when sanding some woods (e.g. MDF) and metal which may produce toxic dust:**
 - Wear a dust mask specifically designed for protection against lead paint dust and fumes and ensure that persons within or entering the work area are also protected.
 - Do not let children or pregnant women enter the work area.
 - Do not eat, drink or smoke in the work area.
 - Dispose of dust particles and other debris safely.
11. Abrasive wheels should be stored and handled with care. (when not in use, accessories should be stored in the box provided for protection).
12. Inspect grinding wheels/accessories before use. Do not use chipped, cracked or otherwise defective products.
13. Ensure that all accessories are fitted in accordance with the manufacturers instructions.
14. Ensure that the abrasive accessory is correctly mounted and tightened before use. Run the tool with no-load for 30 seconds in a safe position and stop immediately if there is vibration or if other defects are detected. If this condition occurs, check the machine to determine the cause.
15. Check that the work piece is properly supported.
16. Do not use a cut-off wheel for side grinding.

17. Ensure that sparks resulting from use do not create a hazard e.g. do not hit persons, or ignite flammable substances.
18. Ensure ventilation openings are kept clear when working in dusty conditions. If it should become necessary to clear dust, first disconnect the battery from the rotary tool.
19. Personal protective equipment such as dust masks and gloves should be worn as appropriate.
20. Remember the wheel continues to rotate after the tool is switched off.

THE BATTERY

NOTES ON CHARGING

- During use, the battery pack may become warm. Allow it to cool before recharging.
- Never store the battery pack when it is discharged, recharge it fully before storage.

TO REMOVE THE BATTERY

- Press either side of the battery and pull it out of the rotary tool.

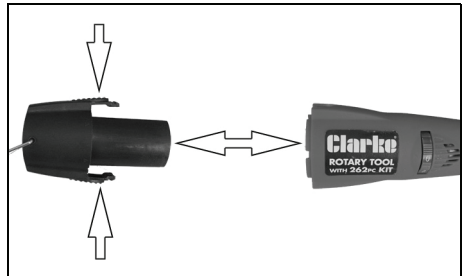

TO CHARGE THE BATTERY

1. Slide it into the charger unit.
 - Make sure that the battery is fully inserted.
 - The red LED will light to show that the battery is charging.
2. When the battery has been fully charged, the red LED will extinguish and the green LED will light.
 - The charger will continue to deliver a slow charge to maintain the battery until the charger is disconnected from the mains supply.
 - Whilst charging, the battery pack and charger may become warm. This is normal and should be expected.
3. When charging is complete, remove the battery from the charger and disconnect the charger from the mains supply.

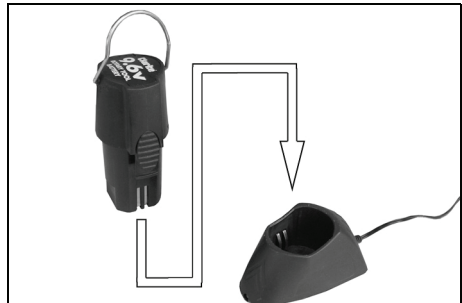

INSERTING THE BATTERY

1. Align the battery with the base of the handle and slide it into the locating clip.
 - Make sure that the battery pack is fully located and clicks into place.

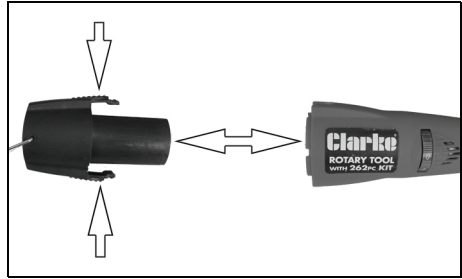

BEFORE USE

FITTING DISCS & GRINDING STONES TO THE MANDREL

Mount the selected disc on to the mandrel as shown, ensuring the two washers are in place.

- DO NOT overtighten the screw.

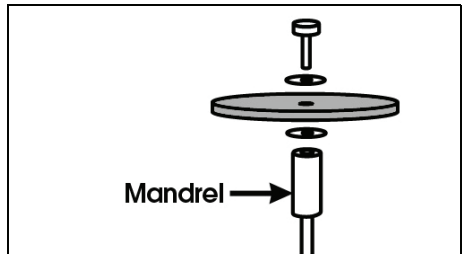

ASSEMBLING POLISHING CLOTH WHEELS

Screw the cloth wheel on to the mandrel firmly, but do not overtighten it.

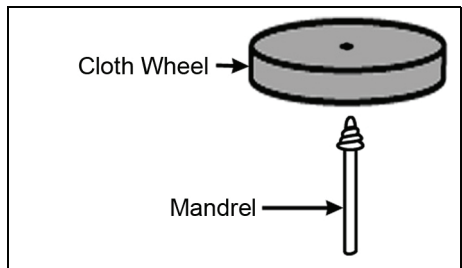

ASSEMBLING SANDING BANDS

Slacken the screw on the end of the mandrel and slide the appropriate abrasive band on to the rubber former, fully.

- Tighten the screw to secure the band to the former.

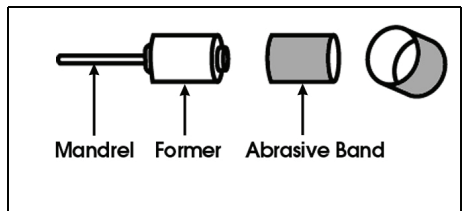

FITTING A COLLET



WARNING: MAKE SURE THAT THE BATTERY HAS BEEN REMOVED FROM THE ROTARY TOOL BEFORE REMOVING, OR FITTING A COLLET OR ACCESSORY

The rotary tool is supplied with 4 interchangeable collets; 0.8mm - 1.6mm - 2.4mm and 3.2mm (fitted to the rotary tool).

Select the collet to be fitted according to the shaft size of the mandrel or accessory to be used.

To fit a collet, proceed as follows.

1. Press and hold down the spindle lock. It may be necessary to rotate the chuck to fully engage the spindle lock.
2. Remove the chuck by rotating the chuck sleeve in an anti-clockwise direction. A spanner is supplied for this purpose.
3. Pull the collet out of the spindle.
4. Insert the collet required, pushing it into the spindle as far as it will go.
5. Refit the chuck, pressing the spindle lock to tighten it.

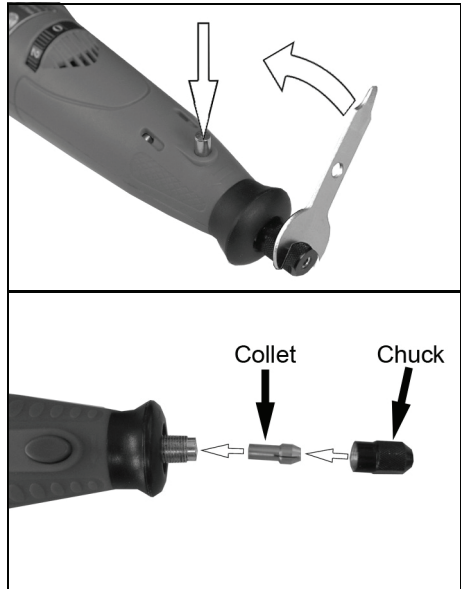

FITTING AN ACCESSORY

IMPORTANT: Ensure the tool is switched OFF

TO FIT AN ACCESSORY, PROCEED AS FOLLOWS.

1. Make sure that the correct size collet has been fitted.
2. Press and hold down the spindle lock.

- It may be necessary to rotate the chuck to fully engage the spindle lock.

3. Rotate the chuck sleeve in an anticlockwise direction until the collet jaws are open sufficiently to accept the accessory.



4. Insert the accessory into the collet as far as it will go.

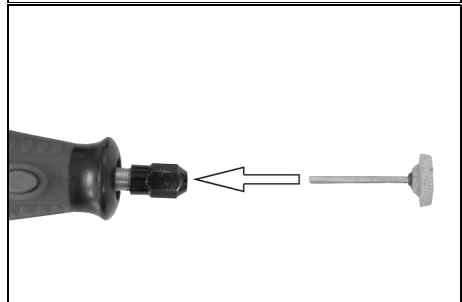

5. Press and hold down the spindle lock and tighten the chuck sleeve using the spanner supplied.

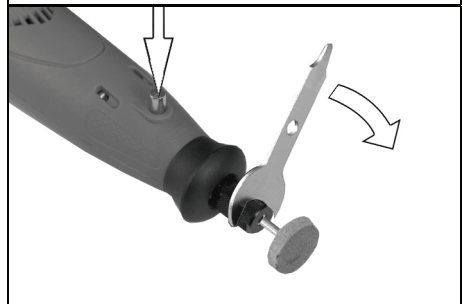

TO REMOVE THE ACCESSORY FROM THE COLLET, PROCEED AS FOLLOWS.

1. Press and hold down the spindle lock.
2. Using the spanner supplied, rotate the chuck sleeve in an anti-clockwise direction.
3. When the accessory is released, remove it.

OPERATING INSTRUCTIONS

OPERATING THE ROTARY TOOL



WARNING: BEFORE OPERATING THE ON/OFF SWITCH, MAKE SURE THAT THE COLLET AND ACCESSORIES HAVE BEEN CORRECTLY AND SECURELY FITTED.

1. To switch the rotary tool on, rotate the speed control away from 0.
2. Select a suitable speed using the speed controller.
 - The low speed settings should be used for removing rust, and polishing.
 - The medium speed settings should be used for drilling, engraving, sharpening and removing paint.
 - The high speed settings should be used for cutting metal and sanding wood.
3. To switch the rotary tool off, set the speed control to 0.

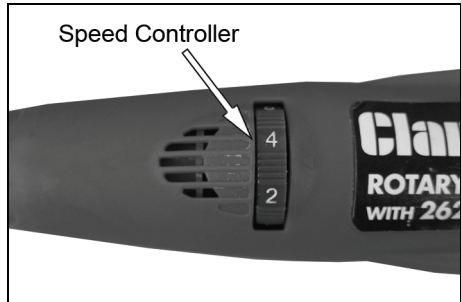

WARNING: ALWAYS WAIT FOR COMPLETE RUN DOWN, AND THE ACCESSORY TO STOP ROTATING, BEFORE PUTTING THE ROTARY TOOL ASIDE.

CLEANING AND MAINTENANCE



WARNING: MAKE SURE THAT THE BATTERY HAS BEEN REMOVED FROM THE ROTARY TOOL BEFORE STARTING ANY CLEANING, OR MAINTENANCE PROCEDURES.

- After use, thoroughly clean all excess chippings and dust from the rotary tool, taking special care to clean the cooling vents.
 - Clean the spindle lock, the chuck and the spindle collar.
 - Keep all accessories sharp and clean.
 - There are no user serviceable parts inside this rotary tool.
 - Worn, or damaged parts should be replaced by qualified personnel.
 - Refer to qualified service personnel if internal maintenance is required.
-

ENVIRONMENTAL PROTECTION



Recycle unwanted materials instead of disposing of them as waste. All tools, accessories and packaging should be sorted, taken to a recycling centre and disposed of in a manner which is compatible with the environment.

DECLARATION OF CONFORMITY



Clarke[®]
INTERNATIONAL

Hemnall Street, Epping, Essex CM16 4LG

DECLARATION OF CONFORMITY

This is an important document and should be retained.

We hereby declare that this product(s) complies with the following directive(s):

2014/30/EC *Electromagnetic Compatibility Directive.*

2006/42/EC *Machinery Directive.*

2011/65/EC *Restriction of Hazardous substances.*

The following standards have been applied to the product(s):

BS EN 60335-1:A11:2014, BS EN 60335-2-29:2004, EN 60745-2-1:2010, EN 60745-1+A11:2010,

EN 55014:2006+A2:2011, EN 55014-2:1997+A2:2008, IEC 62133:2002, BS EN 62233:2008.

The technical documentation required to demonstrate that the product(s) meet(s) the requirement(s) of the aforementioned directive(s) has been compiled and is available for inspection by the relevant enforcement authorities.

The CE mark was first applied in: 2007

Product Description: 266pcs Cordless Rotary Tool Set
Model number(s): CCRT266
Serial / batch Number: N/A
Date of Issue: 19/08/2016

Signed:

J.A. Clarke
Director

PARTS LIST

Part	Part number	Part	Part number
1 x Cordless Grinder	ETCCRT26601	3x Aluminium oxide grinding wheel with shank	ETCCRT26614
1 x Charger Base	ETCCRT26602	2 x Silicon carbide grinding wheel with shank	ETCCRT26615
1 x Adaptor 12V AC 500mAh	ETCCRT26603	6 x Diamond wheel points 1/8" shank	ETCCRT26616
1 x Battery 700mAh	ETCCRT26604	1 x HSS cutter	ETCCRT26617
1 x Polishing Compound	ETCCRT26605	2 x Polished HSS twist drills 1/16"	ETCCRT26618
30 x Cut off wheel Heavy Duty 1 5/16" x 1/32"	ETCCRT26606	1 x Polished HSS twist drills 3/32"	
44 x Cut off wheel regular 15/16" x 1/64"	ETCCRT26607	1 x Polished HSS twist drills 1/8"	
132 x Sanding disc comprising off	ETCCRT26608	1 x Mandrel for felt wheel	ETCCRT26619
(45 x 180 Grit)		2 x Mandrel for cut off wheel 1/16" screw	
(45 x 220 Grit)		1 x Mandrel for cloth wheel 3/32" screw	
(42 x 240 Grit)		2 x Collet chrome plated 1/8"	
6 x Sanding band 1/4" x 1/2"	1 x Collet chrome plated 3/32"		
6pcs sanding band 1/2" x 1/2"	1 x Collet chrome plated 1/16"		
1 x cloth wheel 1" x 1/8"	ETCCRT26610	1 x Wrench 3/8"	ETCCRT26621
1x sanding shank 1/2" x 1/2"	ETCCRT26611	1 x Rubber emery wheel 7/8" x 5/32"	ETCCRT26622
1x sanding shank 1/4" x 1/2"		1 x Stainless brush axial 3/16" x 1-3/4"	ETCCRT26623
2 x felt polishing wheel 1/2" x 3/8"	ETCCRT26612	1 x Stainless brush axial 1/2" x 1-3/4"	
1x felt wheel point 3/8" x 3/4"	1 x felt polishing wheel 1"	1 x Stainless brush radial 13/16" x 1-3/4"	
1x Dressing stone silicon carbide 1" x 3/8"	ETCCRT26613	3 x Aluminium oxide grinding wheel 3/4" x 1/8"	ETCCRT26625
		3 x Silicon carbide grinding wheel 3/4" x 1/8"	

ADVERTISEMENT

For heavier duty work you may be interested in our mains powered rotary tool set Model number CRT40. Also available is our CRT100A- 100pc Accessory Kit for CRT40



This is available from you Clarke dealer

A SELECTION FROM THE VAST RANGE OF

Clarke®

QUALITY PRODUCTS

AIR COMPRESSORS

From DIY to industrial, Plus air tools, spray guns and accessories.

GENERATORS

Prime duty or emergency standby for business, home and leisure.

POWER WASHERS

Hot and cold, electric and engine driven - we have what you need

WELDERS

Mig, Arc, Tig and Spot. From DIY to auto/industrial.

METALWORKING

Drills, grinders and saws for DIY and professional use.

WOODWORKING

Saws, sanders, lathes, mortisers and dust extraction.

HYDRAULICS

Cranes, body repair kits, transmission jacks for all types of workshop use.

WATER PUMPS

Submersible, electric and engine driven for DIY, agriculture and industry.

POWERTOOLS

Angle grinders, cordless drill sets, saws and sanders.

STARTERS/CHARGERS

All sizes for car and commercial use.



PARTS & SERVICE: 0208 988 7400

E-mail: Parts@clarkeinternational.com or Service@clarkeinternational.com

SALES: UK 01992 565333 or Export 00 44 (0)1992 565335

Clarke® INTERNATIONAL Hemnall Street, Epping, Essex CM16 4LG
www.clarkeinternational.com