

CLAMPBEE®



BICYCLE REPAIR STAND

MODEL NO: CBWS

PART NO: 7610197

OPERATION & MAINTENANCE
INSTRUCTIONS



LS1213

INTRODUCTION

Thank you for purchasing this CLARKE product.

Before attempting to use this product, please read this manual thoroughly and follow the instructions carefully. In doing so you will ensure the safety of yourself and that of others around you, and you can look forward to your purchase giving you long and satisfactory service.

GUARANTEE

This product is guaranteed against faulty manufacture for a period of 12 months from the date of purchase. Please keep your receipt which will be required as proof of purchase.

This guarantee is invalid if the product is found to have been abused or tampered with in any way, or not used for the purpose for which it was intended.

Faulty goods should be returned to their place of purchase, no product can be returned to us without prior permission.

This guarantee does not effect your statutory rights.

SPECIFICATION

Dimensions	430 x 620 x 1060 mm
Weight	8.16 kg

ASSEMBLY

1. Place the four legs onto the base plate as shown.

- On one end of the leg there are 2 holes, this end should go towards the centre of the base plate
- On the other end of the leg make sure that the hole is pointing towards the floor.

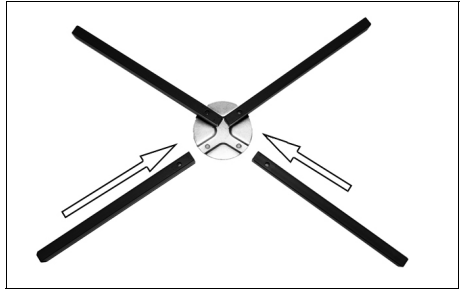

2. Place the lower column onto the legs and secure using the four long bolts and spring washers provided.



3.

4. Slip the tool tray on to the upper column as shown.

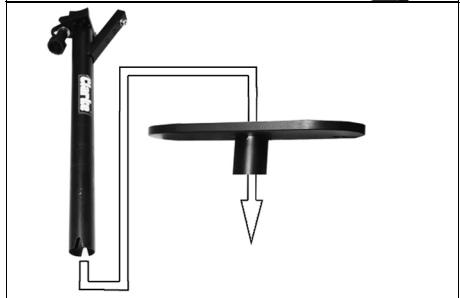

5. Place the spring washer and washer onto the long bolt.
6. Pass the bolt through one of the holes in the lower column as shown.
 - The holes provide three different working heights.
7. Secure using the wing nut.

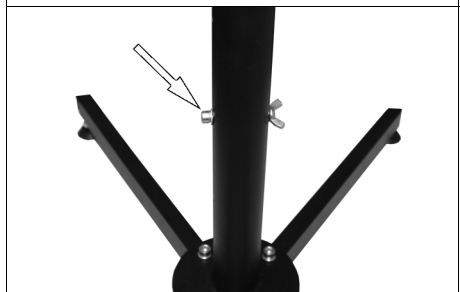

8. Slide the upper column into the lower column until it is resting on the bolt inserted previously.
9. Tighten the adjustable knob clockwise until hand tight.



10. Slide the bike frame holder assembly onto the square tube located on the upper column.
11. Fasten with small hex bolt provided.

- You have three locations to choose from depending on the size of the bicycle.

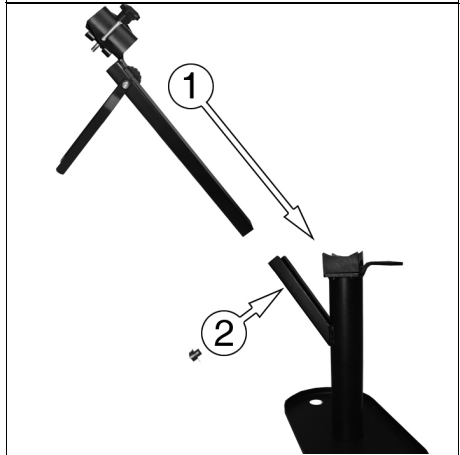

USING THE STAND

1. Place the lowest point of the bicycle frame onto the stand.



2. Pass the T-bar through the bicycle frame as shown and secure with the washer and hand wheel.

NOTE: The gear assembly is not shown for clarity.

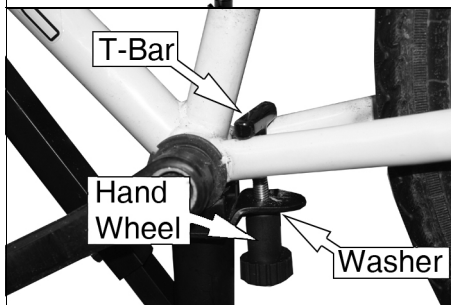

3. Clamp the sloping crossbar to the stand as shown.



4. Place the front arms either side of the front wheel.

5. Tighten the hand wheel to hold them in place.

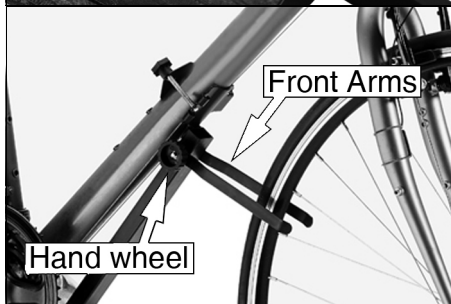

ACCESSORIES

BIKE TRAINER - CCTS



- Magnetic Resistance
- Folds Flat For Easy Storage
- Part No. 4510001

BIKE TRAINER - CCTI



- 7 Level Magnetic Resistance
- Folds Flat For Easy Storage
- Contains A Front Wheel Base For Extra Stability
- Part No. 4510005

BIKE TRAINER - CCTQR



- 7 Level Magnetic Resistance
- Quick Release
- Folds Flat For Easy Storage
- Part No. 4510003

SPIRAL BIKE LOCK - CHT727



- PVC Coated Steel Cable
- Quick Release Bracket
- Lightweight
- Part No. 1081727

A SELECTION FROM THE VAST RANGE OF

Clarke®

QUALITY PRODUCTS

AIR COMPRESSORS

From DIY to industrial, Plus air tools, spray guns and accessories.

GENERATORS

Prime duty or emergency standby for business, home and leisure.

POWER WASHERS

Hot and cold, electric and engine driven - we have what you need

WELDERS

Mig, Arc, Tig and Spot. From DIY to auto/industrial.

METALWORKING

Drills, grinders and saws for DIY and professional use.

WOODWORKING

Saws, sanders, lathes, mortisers and dust extraction.

HYDRAULICS

Cranes, body repair kits, transmission jacks for all types of workshop use.

WATER PUMPS

Submersible, electric and engine driven for DIY, agriculture and industry.

POWER TOOLS

Angle grinders, cordless drill sets, saws and sanders.

STARTERS/CHARGERS

All sizes for car and commercial use.



PARTS & SERVICE: 020 8988 7400

E-mail: Parts@clarkeinternational.com or Service@clarkeinternational.com

SALES: UK 01992 565333 or Export 00 44 (0)1992 565335

Clarke® INTERNATIONAL Hemnall Street, Epping, Essex CM16 4LG
www.clarkeinternational.com