



Petrol Stump Grinder Operator's Manual BSF15

**FOR YOUR SAFETY
READ AND UNDERSTAND THE ENTIRE MANUAL
BEFORE OPERATING THIS MACHINE**

Warranty Registration Form

Model:	
Serial Number:	
Type of Use:	Business / Domestic
Name:	
Business Name:	
Address:	
Email Address:	
Phone Number:	
Date of Purchase:	
Place of Purchase:	
Proof of Purchase enclosed:	

For the warranty to be valid the Warranty Registration Form must be completed and returned to Lumag Distribution Limited within 14 days of the purchase, together with a copy of the purchase invoice.

We will use your email to confirm that we have received the completed Warranty Registration Form and contact you about any errors or omissions on the form. We may occasionally use this email address to make you aware of news, technical advice and special offers. If you do not wish to receive such emails please tick this box.



Lumag Servicing and Maintenance Schedules

To maximise the life of your Lumag machine it needs to be serviced and maintained at every indicated month or operating hour interval, whichever comes first, in accordance with the below Schedules. Please note that failure to service your machine on schedule or use genuine Lumag parts and consumables will result in your warranty being void.

Engine Service & Maintenance Schedule

Item	Checks/Work	Each Use	20hrs (1st Month)	50hrs (2nd Month)	100hrs (6th Month)	300hrs (Yearly)
Engine Oil	Check Level	X				
	Change		X (1)		X	
Air Filter	Check	X				
	Clean			X (3)		
	Replace					X (4)
Sediment Cup	Clean				X	
Spark Plug	Check/Clean				X	
	Replace					X
Idle Speed	Check/Adjust					X (2)
Valve Clearance	Check/Adjust					X (2)
Fuel Tank Strainer	Check/Clean					X (2)
Combuster Chamber	Inspect/Clean					X (2)
Fuel Lines	Check					X (2)

Engine Oil	1000ml	Lumag Engine 1
------------	--------	----------------

Machine Service & Maintenance Schedule

Item	Checks/Work	Each Use	Weekly	20hrs (1st Month)	50hrs (2nd Month)	100hrs (6th Month)	300hrs (Yearly)
Grease Main Bearing	Check Level	X					
Fasteners Tension Check	Check	X					
Clean Machine	Check	X					
Inspect Clutch	Check/Adjust						X (2)
Drive Belt	Check/Adjust		X				
	Replace						X (2)
All Other Moving Parts & Cables	Lubricate			X			X (2)

1 – First service only, 2 = Should be carried out by your Lumag Dealer, 3 = May need to be done more often in dusty areas & 4 = Replace paper element only

Service & Maintenance Record

Product Details:	Model: _____ Serial number: _____ Purchase Date: _____	Parts Used? Y/N	Parts Invoice Number:	Dealers Name:	Engineers Name:	Engineers Signature:
	Description of checks/work carried out:					

Please note that failure to service your machine on schedule or use genuine Lumag parts and consumables will result in your warranty being void

TABLE OF CONTENTS

PREFACE	pg 3
PARTS	pg 4
SAFETY PRECAUTIONS	pg 5
OPERATIONS	pg 7
MAINTENANCE	pg 11
SPECIFICATIONS	pg 12

PREFACE

Thanks for buying the Stump Grinder, another high-quality machine from our company.

To get the most out of your purchase, please read the manual before using the stump grinder.

We ask you to please read this manual carefully beforehand in order to familiarise yourself with this product and after reading, please store this instructional manual for future reference. Failure to follow the proper protocols listed in the manual may cause personal injury to the operator or damage to equipment.

PARTS

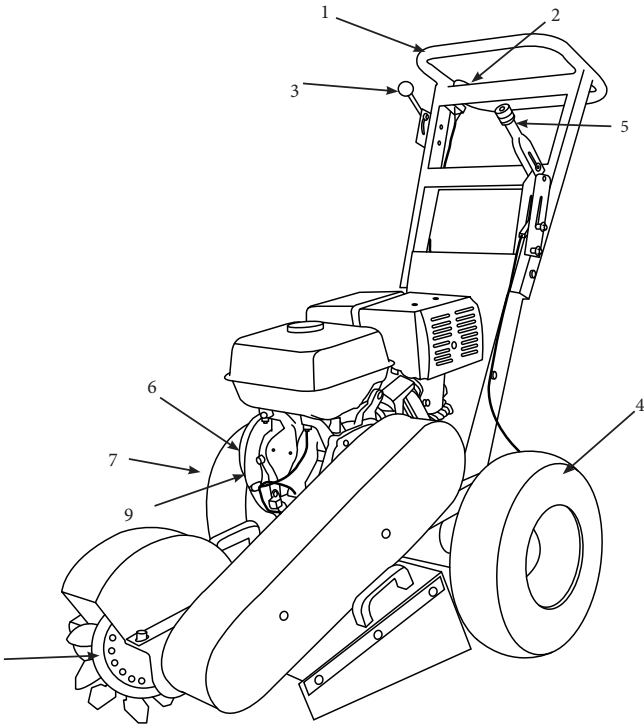

1	Handle Bar
2	Emergency Stop Switch (On/Off)
3	Throttle
4	Wheel
5	Brake Lever
6	Engine
7	Pull Start (behind)
8	Cutting Wheel
9	Kill Switch

SAFETY PRECAUTIONS

- Keep the working area clean and well lit.
- Do not operate the stump grinder in the presence of flammable liquids, gases or dust.
- Keep children and bystanders away while operating the stump grinder. Keep the area free of all distractions.
- Only responsible, properly instructed individuals should operate this machine.
- Inexperienced operators must always be carefully supervised.
- Do not expose stump grinders to rain or wet conditions.
- Stay alert, watch what you are doing and use common sense when operating a stump grinder. Do not use a stump grinder while you are tired or under the influence of drugs, alcohol or medication. A moment of inattention while operating any stump grinders may result in serious personal injury.
- Use safety equipment. Always wear eye protection. Safety equipment such as dust mask, non-skid safety shoes, hard hat, or hearing protection used for appropriate conditions will reduce personal injuries.
- Dress properly. Do not wear loose clothing or jewelry. Keep your hair, clothing and gloves away from moving parts. Loose clothes, jewelry or long hair can be caught in moving parts.
- Always wear earplugs to protect your ears.
- Do not start the engine until the machine is in the cutting position next to the stump.
- Do not overreach. Keep proper footing and balance at all times. This enables better control of the stump grinder in unexpected situations.
- If devices are provided for the collection of dust extraction, ensure these are connected and properly used. Use of these devices can reduce dust related hazards.
- Check stumps to be removed for embedded nails, wire, metal fence posts and other metallic objects and for rocks or other buried impediments which may become dangerously thrown or cause unexpected machine movements when hit by the cutting wheel.
- Make sure that all shields and guards are in place and are in good condition prior to operating the machine. Check cutting wheel for damage or missing teeth and replace as necessary.

- Ensure that everyone in the vicinity is aware of the **danger zone** associated with this machine(see diagram). You must avoid the **danger zone** at all times when the machine is in operation.



- Make sure that no-one is working on underneath or close to the machine before starting the engine or beginning to move the machine. Make sure that the area is free of personnel.
- Don't make any alterations or modifications to your stump grinder.
- Check with your local council and utility providers for the locations of buried pipes and cables where applicable, before operating the machine.

FUEL SAFETY

- Pay attention while handling fuel. They are flammable and the vapours are highly explosive.
- Never remove the fuel cap or add fuel with the power running. Stop the engine and allow engine and exhaust components to cool before refueling.
- Do not smoke while adding fuel.
- Fill your engine with 10w-30/ 10w-40/ 15w-30/ 15w-40 non-synthetic engine oil before use or serious damage will occur.
- Use extreme care when handling fuel. Fuel is extremely flammable and the vapors are explosive. Never fuel machine indoors or while the engine is hot or running.
- Never refuel or store the machine in a place where there is open flame, spark or other ignition objects.
- Do not attempt to start the engine if fuel is spilled. Wipe away the spillage and ensure all fuel has dried before starting the machine.
- Always make sure the fuel cap is securely tightened and replace before starting.
- If the fuel tank needs to be drained, it should be done outdoors.

OPERATIONS

ADDING OIL TO THE ENGINE

1. Only fill the fuel tank to a level 15mm lower than the top of the fuel tank. Do not overfill.
2. Use the dipstick to check the oil level. Use 10w-30/ 10w-40/ 15w-30/ 15w-40 non-synthetic engine oil. Fill to the correct level before use.

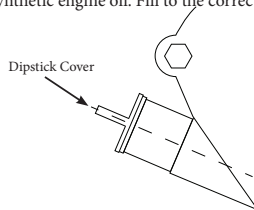

The engine is shipped without oil. Fill to the correct level before use. Operating the engine with no oil or oil at a low level will destroy the engine- this is not covered under warranty.

STARTING THE ENGINE

1. Lock travel wheel by pulling brake lever fully back.
2. Make sure throttle is in slow position.

Do not allow the rope to snap back, return it by hand to prevent damage to the starter.

3. If the engine is cold, move the choke lever to the closed position.
4. Raise the cutter wheel 4 to 5 inches off the ground by pushing downwards on the handle bar, hold it in that position.

The next step may cause the cutter wheel to rotate, keep everyone away.

5. Pull the starter rope lightly until resistance is felt then pull briskly.
6. Move the choke lever to the open position.

The next step causes the cutter wheel to rotate, keep everyone away.

7. Move the throttle to fast. if the engine is cold, allow the engine to idle(throttle set to slow) for a few minutes before cutting.

REMOVING STUMPS

- Remove all loose pieces of wood, stones, wire and other debris from the area before beginning stump removal.
- Wind direction should be considered, as it influences the direction in which dust and wood chips are directed.
- Never operate the grinder after dark. There will be no adequate light for the operator to use the grinder safely.
- Always allow a cold engine time to warm up before cutting a stump.
- Only the portion of cutting wheel within the 80 degree area shown above should engage the stump. Never undercut the stump or use the bottom of the cutting wheel for cutting purposes.

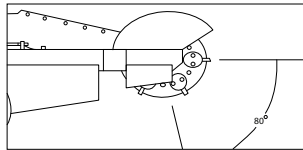

- Never leave controls when the cutting wheel is rotating.

Operating Tips!

- Use smooth, comfortable side to side movements while operating.
- When it is desired to cut smaller roots, it may be more effective to do so before rather than after cutting the stump.
- Should the chip build-up become excessive when cutting, shut off the machine, wait for the cutting wheel to stop rotating, retract the machine from the stump and rake away the chips. It is also possible to use the cutter wheel to push chips off to the side.
- **In order to prevent any of the wheels becoming stuck in the hole. Move the grinder to the other side of the stump to continue removal or by filling the hole with chips before continuing.**

Prepare the grinder at the stump.

Place it into position with the cutting wheel near the top edge of the stump.

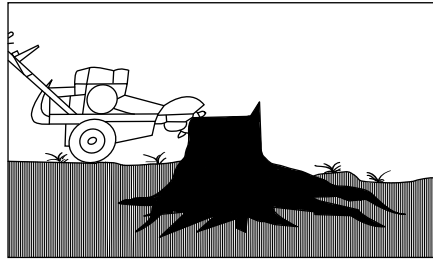

Removing roots

1. Make sure the throttle is set to **fast**, the cutter wheel will accelerate to cutting speed.
2. Swing the cutting wheel to one side, then lower it into the nearest roots that are buried at the foot of the stump.
3. Swing the cutting wheel before each sweep, until the roots are sufficiently removed.

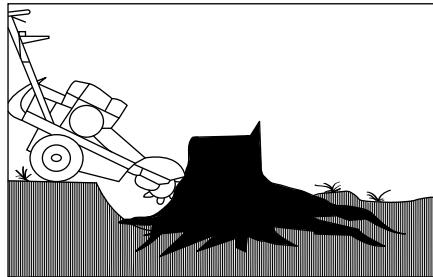

4. Raise the cutting wheel until the centre of the cutting wheel is just above the top of the stump.
5. Allow the cutter wheel to stop, release the brake and reposition the machine.
6. Lock the brake again.

Cutting the full stump

1. Make sure the throttle is set to **fast**. The cutter wheel will accelerate to cutting speed.
2. Direct the cutter wheel against the stump, beginning with the nearest top corner of the stump, and steadily sweep it across the stump left and right, cutting away 1/2 inch of wood with each sweep.
3. Raise and lower the cutter wheel between sweeps by lowering and raising the control handle.
4. Roll the machine forward and back, by pushing and pulling on the control handle. To do this, release the brake. Relock it when the machine has been repositioned and continue cutting.

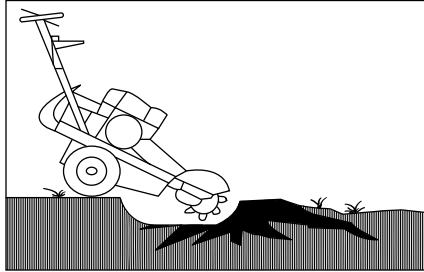

Continue with final roots removal

Cut the remaining roots as described in STEP 2 until satisfactorily removed

SHUTTING OFF THE GRINDER

1. When stopping the machine after normal operation, lower engine speed to **slow**, and push the emergency switch.
2. Set park brake before leaving the controls.
3. **Shut off the engine by pushing the on/off switch.**

NORMAL SHUTDOWN PROCEDURE

In consideration of your own safety and that of others, you should always use the following normal shutdown procedures before departing from the controls for any reason including cleaning, servicing, transporting or inspecting the stump grinder. Never deviate from this procedure unless so instructed in this manual or in an emergency that requires it.



A rotating cutting wheel is very dangerous. Stand at controls and ensure that the cutting wheel comes to a complete stop before doing anything else.

1. Move the engine throttle to the **slow** position.
2. Push the emergency (on/off) switch to stop the engine.
3. Set park brake before leaving controls.

EMERGENCY SHUT DOWN PROCEDURE

1. Immediately push the emergency (on/off) switch for the engine will be shut off.
2. Be sure to allow all moving parts to come to a complete stop.
3. Pull the brake lever to engage the brake.
4. Rectify the emergency situation and return to normal operation.

MAINTENANCE

- Make sure all nuts, bolts and screws are tightened.
- Never store the equipment with petrol in the tank inside a building where fumes can reach an open flame or spark. Allow the engine to cool before moving the grinder.
- To reduce fire hazards, keep the engine and petrol storage area free of grass, dirt and excessive grease.
- Replace worn or damaged parts for safety. If the fuel tank has to be drained, this should be done outdoors.
- Regularly check the oil level and add some oil or replace it if necessary.
- Frequently check the grinder and ensure that all bark and dirt deposits are removed from beneath the deck.
- Lubricate the wheel axle and the bearings with grease regularly.
- Check the cutting wheel often. In order to achieve clean work the blade should always be sharp and well balanced.
- Check the tightening of all bolts and screws at regularly intervals. Nuts and bolts that are worn out or badly tightened can damage the engine or the frame.
- If the grinder hits an obstacle violently, stop the grinder and take it to a specialist for inspection.

TRANSPORTATION

The stump grinder is designed to be transported via a van or small trailer. The machine is equipped with grab bars that are to be used for both lifting the machine, and strapping it down. This machine weighs approximately 110kg and should only be lifted using correct apparatus or an adequate number of people working as a team.

There are legal road requirements for towing equipment and trailers (such as lighting and licensing). It is the owner's responsibility to be aware of these laws and to adhere to them.

SPECIFICATIONS

Engine	15HP Four Strokes
Brake	Drum Brake
Belt	2PCS v Belt
Clutch	Centrifugal Clutch
Blades	12 Blades w Tungsten (4x left, 4x right, 4x middle)
Cutting Depth	12inch
Packing Size	1040*780*580mm
Gross Weight	130kgs
Net Weight	110kgs

PART DRAWINGS

FOR YOUR SAFETY
READ AND UNDERSTAND THE ENTIRE MANUAL
BEFORE OPERATING THIS MACHINE

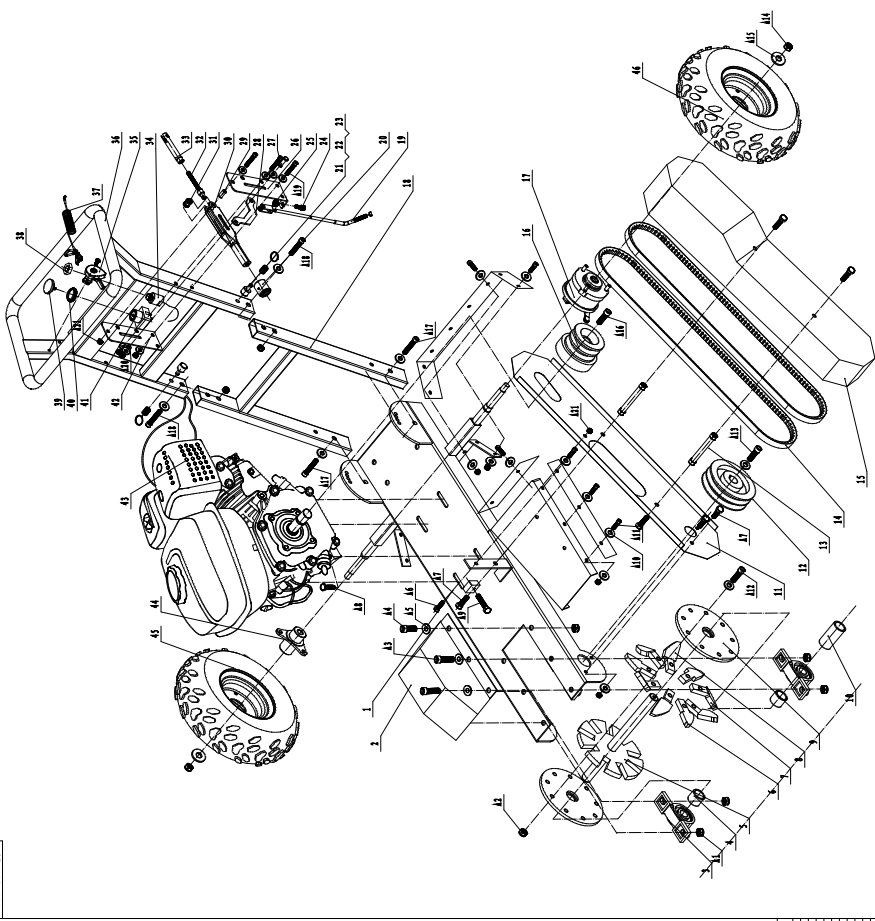



Unit 10, Hatchmoor Industrial Estate, Hatherleigh, Okehampton, Devon EX20 3LP
www.lumag-gb.co.uk 01837 811741

Lumag Distribution Limited Company Number: 09267547 VAT Number: GB154566788 Hatherleigh