

CLARKE®



BATTERY STARTER/CHARGER

MODEL NO: BC125, BC190

PART NO: 6210125, 6210200

OPERATION & MAINTENANCE INSTRUCTIONS



ORIGINAL INSTRUCTIONS

GC 0820 - REV 9

INTRODUCTION

Thank you for purchasing this CLARKE Battery starter / charger

Please read this manual thoroughly, before attempting to operate, and carefully follow all instructions given.

It is vitally important that ALL precautions are taken, as specified, which will not only provide protection for yourself and that of others around you, but will also ensure that the Battery Charger will give you long and satisfactory service.

GUARANTEE

This CLARKE product is guaranteed against faulty manufacture for a period of 12 months from the date of purchase. Please keep your receipt as proof of purchase.

This guarantee is invalid if the product is found to have been abused or tampered with in any way, or not used for the purpose for which it was intended.

Faulty goods should be returned to their place of purchase, no product can be returned to us without prior permission.

This guarantee does not effect your statutory rights.

ENVIRONMENTAL RECYCLING POLICY



By purchasing this product, the customer is taking on the obligation to deal with its safe disposal in accordance with the WEEE regulations for the ethical disposal of the WEEE.

 This means that this product must not be disposed of with general household waste. It must be disposed of according to the laws governing Waste Electrical and Electronic Equipment (WEEE) at a recognised disposal facility.

SAFETY PRECAUTIONS



WARNING: BECAUSE HIGHLY INFLAMMABLE HYDROGEN GAS IS RELEASED IN THE PROCESS OF BATTERY CHARGING, ALWAYS REMEMBER TO SWITCH OFF FIRST AND SO AVOID SPARKING, WHICH WILL OCCUR WHEN CONNECTING OR DISCONNECTING LIVE LEADS.



WARNING: CERTAIN TYPES OF SEALED OR MAINTENANCE-FREE BATTERIES NEED EXTRA CARE WHEN CHARGING. PLEASE CONSULT BATTERY MANUFACTURERS INSTRUCTIONS BEFORE USING THIS UNIT.



WARNING: SINCE TOXIC FUMES MAY BE RELEASED DURING BATTERY CHARGING, ONLY USE THIS UNIT IN A WELL VENTILATED AREA.

1. To prevent the battery from overheating and consequent damage, use the BOOST facility sparingly and do not exceed our recommendations.
2. Battery acid is highly corrosive. If spillage occurs, wipe off immediately and wash copiously with water. Particularly avoid contact with the eyes.
3. Do not expose this unit to rain.
4. Never touch the negative and positive leads together on this unit whilst it is switched on.
5. Never attempt any electrical or mechanical repair. If you have a problem with your machine contact your local stockist for service information.
6. Before charging ensure the battery terminals are clean, and that the cells are filled with electrolyte to the correct level by adding distilled water where necessary.
7. Where appropriate we recommend that the positive (+) lead to the battery is disconnected on the vehicle prior to charging. This will prevent damaging the vehicle electronics.
8. When charging is completed, ensure that the vehicle battery leads are secured to the correct terminals which should be clean and lightly smeared with petroleum jelly to prevent corrosion. Finally, re check the electrolyte level.

ELECTRICAL CONNECTIONS



WARNING: READ THESE ELECTRICAL SAFETY INSTRUCTIONS THOROUGHLY BEFORE CONNECTING THE PRODUCT TO THE MAINS SUPPLY.

Before switching the product on, make sure that the voltage of your electricity supply is the same as that indicated on the rating plate. This product is designed to operate on 230VAC 50Hz. Connecting it to any other power source may cause damage.

This product may be fitted with a non-rewireable plug. If it is necessary to change the fuse in the plug, the fuse cover must be refitted. If the fuse cover becomes lost or damaged, the plug must not be used until a suitable replacement is obtained.

If the plug has to be changed because it is not suitable for your socket, or due to damage, it should be cut off and a replacement fitted, following the wiring instructions shown below. The old plug must be disposed of safely, as insertion into a mains socket could cause an electrical hazard.



WARNING: THE WIRES IN THE POWER CABLE OF THIS PRODUCT ARE COLOURED IN ACCORDANCE WITH THE FOLLOWING CODE: BLUE = NEUTRAL BROWN = LIVE YELLOW AND GREEN = EARTH

If the colours of the wires in the power cable of this product do not correspond with the markings on the terminals of your plug, proceed as follows.

- The **Blue** wire must be connected to the terminal which is marked **N** or coloured **Black**.
- The **Brown** wire must be connected to the terminal which is marked **L** or coloured **Red**.
- The **Yellow and Green** wire must be connected to the terminal which is marked **E** or  or coloured **Green**.

Plug must be BS1363/A approved.

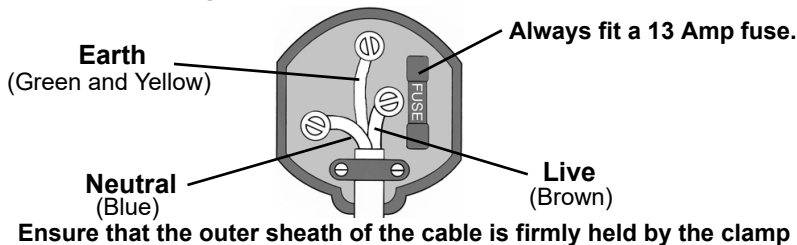

If in any doubt, consult a qualified electrician. DO NOT attempt any repairs yourself.

OVERVIEW

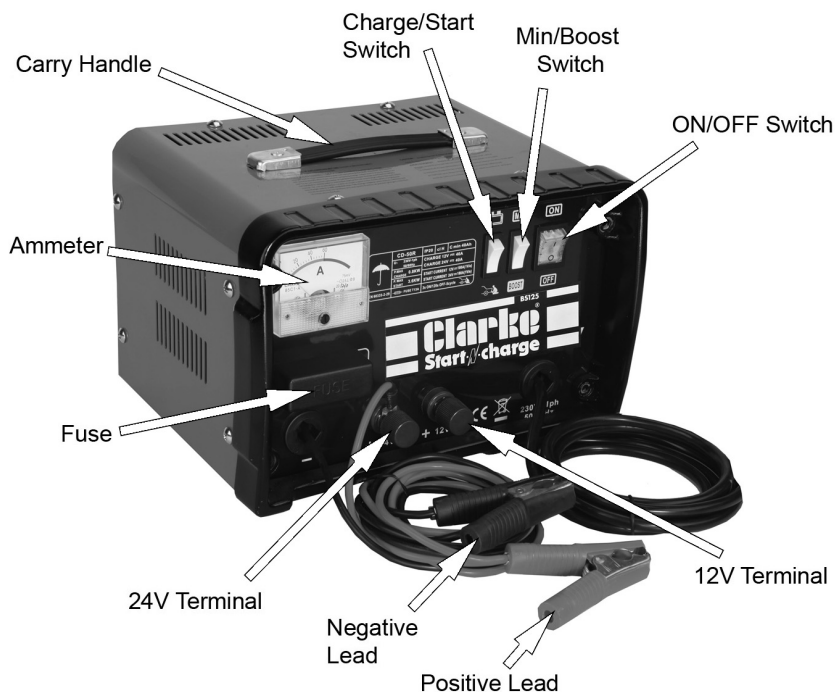

SPECIFICATIONS

	BC125	BC190
Input Voltage	230V AC @ 50 Hz	230V AC @ 50 Hz
Max Rated Output Current	Charging 20 Amps Starting 120 Amps	Charging 38 Amps Starting 180 Amps
Open Circuit Voltage		
MIN 12V/24V	10.05 / 22.54 Volts	10.63 / 23.76 Volts
BOOST 12V/24V	10.40 / 23.46 Volts	11.24 / 25.49. Volts
STARTING 12V/24V	10.58 / 23.97 Volts	11.43 / 25.70 Volts
Boost Start Duty Cycle	3 Seconds ON / 120 seconds OFF - max 5 cycles	3 Seconds ON / 120 seconds OFF - max 5 cycles
Output Protection Fuse	2 x 50A	2 x 110A
Dimensions (D x W x H)	280 x 225 x 200 mm	280 x 225 x 200 mm
Weight (kg)	7.7	8.8
Part Number	6210125	6210200

TO CHARGE THE BATTERY

NOTES ON CHARGING PROCEDURE



WARNING: NEVER ATTEMPT TO RE-CHARGE NON-RECHARGEABLE BATTERIES.



CAUTION: When charging a car battery in situ, we recommend that the non earthed lead on the battery is disconnected prior to charging (On most vehicles, this would be the RED, Positive lead - but check the vehicle handbook if you are unsure). This precaution is necessary as it is possible that damage could occur to any electronically controlled system fitted to the vehicle.

- A complete charge is best done slowly in order to protect your battery, so we recommend setting the MIN/BOOST switch to the MIN position.
- A complete charge may take up to 10 hours.
- If a low amperage reading (2 amps or less) is seen on the Ammeter gauge at either the MIN or BOOST setting, this may indicate that the battery is either (a) already fully charged or (b) at the end of its useful life and in need of replacement.
- Do not charge the battery for longer than is necessary.

SETUP

NOTE: *Make sure that the battery cells are filled with electrolyte to the correct level by adding distilled water.*

1. Check that the ON/OFF switch on the unit is in the OFF position.
2. Connect the RED, positive lead to either the 12V or 24V terminal on the charger, as appropriate.
3. Remove the battery filler caps, where applicable, during charging, to prevent the build up of dangerous gases within the battery.

CONNECTING TO THE BATTERY

4. Connect the RED clamp to the positive (+) terminal.
5. Connect the BLACK clamp to the chassis (or a suitable engine bolt) away from the battery and fuel line.



WARNING: IF THE LEADS ARE CONNECTED TO THE WRONG TERMINALS, A FLASH WILL OCCUR WHEN THE SECOND CLAMP IS CONNECTED. THIS MAY CAUSE THE FUSE TO BLOW, THEREBY PROTECTING THE CHARGER AND BATTERY. IF THIS OCCURS, REMOVE THE BLACK COVER ON THE FRONT PANEL TO ACCESS THE FUSE. AFTER REPLACING THE FUSE ENSURE THE COVER IS REPLACED.

6. Switch the CHARGE/START switch to the CHARGE position.
7. Set the MIN/BOOST switch to the MIN position.
 - This is suitable for charging most normal car batteries.
8. Switch the ON/OFF switch to ON, and charging will commence. You can increase the rate of charge by switching the MIN/BOOST switch to BOOST.
9. Keep the battery on charge until the Ammeter gauge reads less than 2 amps or has stopped moving down.

WHEN CHARGING IS COMPLETE

10. Switch the ON/OFF switch to OFF.
11. ALWAYS disconnect the clamps in the following order - Red then Black.

PROCEDURE FOR ENGINE STARTING

NOTE: *Make sure that the battery cells are filled with electrolyte to the correct level by adding distilled water.*

We recommend that before attempting to boost start, you charge the battery for 10-15 minutes. This will improve the chance of a first time start, particularly with bigger engines. When the battery is completely flat, you must charge the battery for 10-15 minutes before attempting to start, otherwise you may cause damage to the vehicle electronic systems.

1. Set the ON/OFF switch to the OFF position.
2. Connect the RED, positive lead to either the 12V or 24V terminal on the charger, as appropriate.
3. Connect the RED clamp to the positive (+) battery terminal).
4. Connect the BLACK clamp to the chassis (or a suitable engine bolt) away from the battery and fuel line
5. Set the CHARGE/BOOST START switch to the BOOST position.
6. Switch the ON/OFF switch to the ON position.
7. Turn the ignition key to start the car.

IMPORTANT: If the engine fails to start within 3 seconds stop immediately, and return the CHARGE/BOOST START switch to CHARGE position for a period of 120 seconds before retrying. Failure to do this could damage some vehicle electronic equipment, the battery, and possibly the unit which may invalidate your guarantee.

THERMAL OVERLOAD

These starter / chargers are provided with a Thermal Overload cut-out.

Should the Duty Cycle be exceeded, or should the unit overheat for any reason, the thermal overload will intervene, shutting down the system.

If this occurs, wait for 15 - 20 minutes, depending upon ambient temperature, before attempting to re-use.

Once it has reset, the unit is ready for use once again.

DECLARATION OF CONFORMITY



Clarke[®]
INTERNATIONAL

Hemnall Street, Epping, Essex CM16 4LG

DECLARATION OF CONFORMITY

This is an important document and should be retained.

We hereby declare that this product(s) complies with the following directive(s):

- 2014/30/EU *Electromagnetic Compatibility Directive.*
- 2014/35/EU *Low Voltage Equipment Directive.*
- 2011/65/EU *Restriction of Hazardous Substances, (amended by 2015/863).*

The following standards have been applied to the product(s):

- EN 55014-1:2017, EN 55014-2:2015, EN 61000-3-2:2019, EN 61000-3-3:2013+A1:2019,*
- EN 60335-2-29:2004+A2:2010, EN 60335-1:2012+A1:2014, EN 62233:2008.*

The technical documentation required to demonstrate that the product(s) meet(s) the requirement(s) of the aforementioned directive(s) has been compiled and is available for inspection by the relevant enforcement authorities.

The CE mark was first applied in: 2008

Product Description: Battery Charger & Battery Charger/Engine Starter
Model number(s): BC125 / BC190
Serial / batch Number: n/a
Date of Issue: 14/08/2020

Signed:

J.A. Clarke
Director

PARTS DIAGRAM

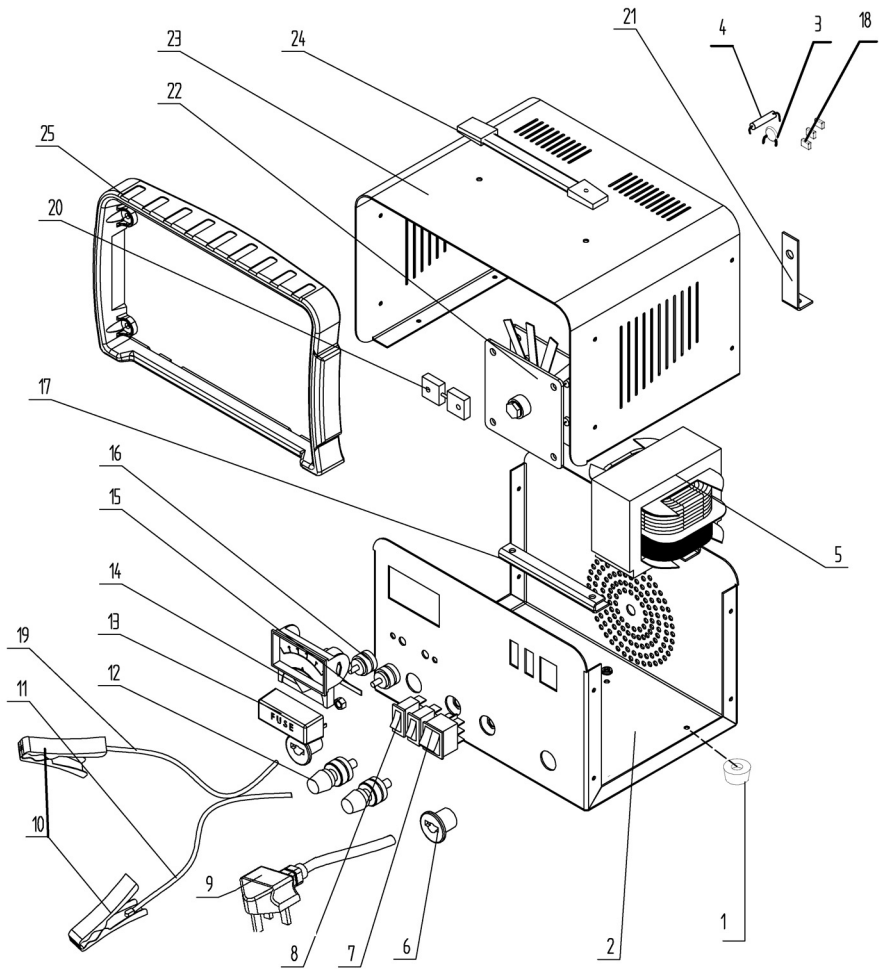

PARTS LIST

No	DESCRIPTION
1	Rubber Feet
2	Front And Back Casing
3	Piezo-resistor
4	Resistor
5	Transformer
6	Rubber
7	On-off Switch
8	Switch
9	Plug Wire
10	Clamp
11	Red Cable
12	Binding Post
13	Fuse Cover
14	Ammeter
15	Fuse
16	Binding Post
17	Support
18	Capacitor
19	Black Cable
20	Shunt
21	Rectifier Bridge Support
22	Rectifier Bridge
23	Casing
24	Handle Belt
25	Plastic Casing

A SELECTION FROM THE VAST RANGE OF

Clarke®

QUALITY PRODUCTS

AIR COMPRESSORS

From DIY to industrial, Plus air tools, spray guns and accessories.

GENERATORS

Prime duty or emergency standby for business, home and leisure.

POWER WASHERS

Hot and cold, electric and engine driven - we have what you need

WELDERS

Mig, Arc, Tig and Spot. From DIY to auto/industrial.

METALWORKING

Drills, grinders and saws for DIY and professional use.

WOODWORKING

Saws, sanders, lathes, mortisers and dust extraction.

HYDRAULICS

Cranes, body repair kits, transmission jacks for all types of workshop use.

WATER PUMPS

Submersible, electric and engine driven for DIY, agriculture and industry.

POWER TOOLS

Angle grinders, cordless drill sets, saws and sanders.

STARTERS/CHARGERS

All sizes for car and commercial use.



PARTS & SERVICE: 0208 988 7400

Parts Enquiries
Parts@clarkeinternational.com

Servicing & Technical Enquiries
Service@clarkeinternational.com

SALES: UK 01992 565333 or Export 00 44 (0)1992 565335

Clarke INTERNATIONAL Hemnall Street, Epping, Essex CM16 4LG
www.clarkeinternational.com