

**DRAPER**  
*Expert*

GB

**3 Year**  
WARRANTY

230V 255/305mm

# DOUBLE BEVEL SLIDING COMPOUND MITRE SAW

79899 & 79901

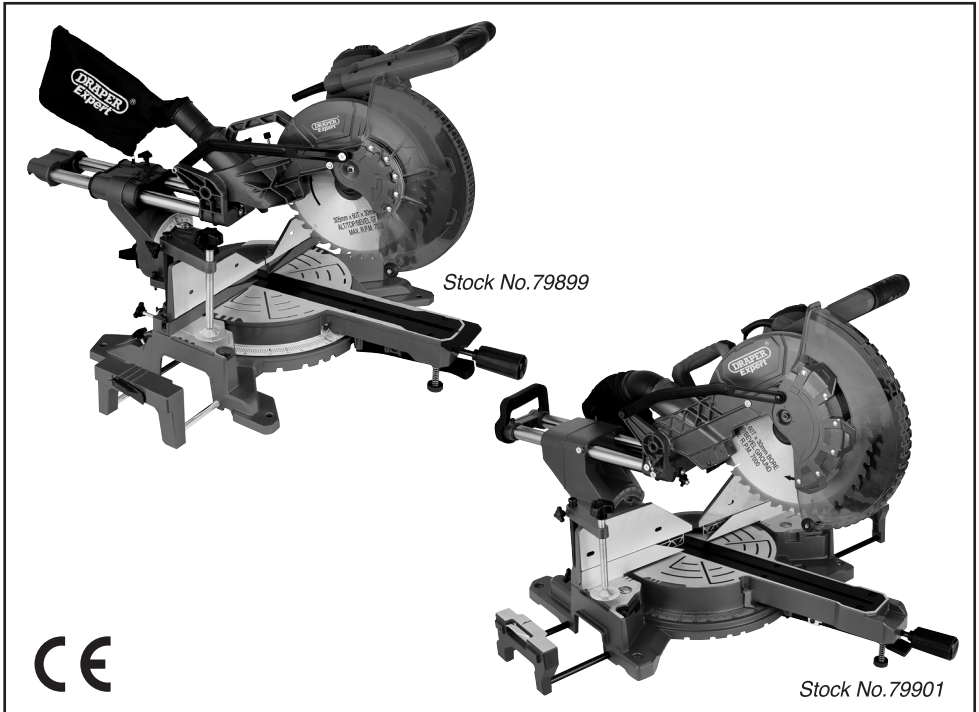

These instructions accompanying the product are the original instructions. This document is part of the product, keep it for the life of the product passing it on to any subsequent holder of the product. Read all these instructions before assembling, operating or maintaining this product.

This manual has been compiled by Draper Tools describing the purpose for which the product has been designed, and contains all the necessary information to ensure its correct and safe use. By following all the general safety instructions contained in this manual, it will ensure both product and operator safety, together with longer life of the product itself.

All photographs and drawings in this manual are supplied by Draper Tools to help illustrate the operation of the product.

Whilst every effort has been made to ensure the accuracy of information contained in this manual, the Draper Tools policy of continuous improvement determines the right to make modifications without prior warning.

# 1. TITLE PAGE

---

## 1.1 INTRODUCTION:

**USER MANUAL FOR: 230V 255/305mm Double Bevel Sliding Compound Mitre Saw**  
**Stock No's: 79899 & 79901**  
**Part No: SMS255E & SMS305E**

## 1.2 REVISIONS:

---

**Date first published March 2019.**

---

---

---

---

As our user manuals are continually updated, users should make sure that they use the very latest version.

**Downloads are available from:** <http://drapertools.com/manuals>

Draper Tools Limited  
Hursley Road  
Chandler's Ford  
Eastleigh  
Hampshire  
SO53 1YF  
UK

**Website:** [drapertools.com](http://drapertools.com)

**Product help line:** +44 (0) 23 8049 4344

**General Fax:** +44 (0) 23 8026 0784

## 1.3 UNDERSTANDING THIS MANUALS SAFETY CONTENT:

**WARNING!** – Information that draws attention to the risk of injury or death.

**CAUTION!** – Information that draws attention to the risk of damage to the product or surroundings.

## 1.4 COPYRIGHT © NOTICE:

Copyright © Draper Tools Limited.

Permission is granted to reproduce this publication for personal and educational use only. Commercial copying, redistribution, hiring or lending is prohibited.

No part of this publication may be stored in a retrieval system or transmitted in any other form or means without written permission from Draper Tools Limited.

In all cases this copyright notice must remain intact.

---

## 2. CONTENTS

---

|          |  |     |
|----------|--|-----|
| <b>1</b> | <b>TITLE PAGE</b>                                      |     |
| 1.1      | INTRODUCTION .....                                     | 2   |
| 1.2      | REVISION HISTORY .....                                 | 2   |
| 1.3      | UNDERSTANDING THIS MANUAL .....                        | 2   |
| 1.4      | COPYRIGHT NOTICE.....                                  | 2   |
| <b>2</b> | <b>CONTENTS</b>  |     |
| 2.1      | CONTENTS.....  | 3-4 |
| <b>3</b> | <b>WARRANTY</b>  |     |
| 3.1      | WARRANTY.....  | 5   |
| <b>4</b> | <b>INTRODUCTION</b>                                    |     |
| 4.1      | SCOPE .....  | 6   |
| 4.2      | SPECIFICATION .....                                    | 6   |
| 4.3      | HANDLING AND STORAGE .....                             | 6   |
| <b>5</b> | <b>HEALTH AND SAFETY INFORMATION</b>                   |     |
| 5.1      | GENERAL SAFETY INSTRUCTIONS FOR POWER TOOL USE .....   | 7   |
| 5.2      | SAFETY INSTRUCTIONS FOR MITRE SAWS .....               | 8   |
| 5.3      | ADDITIONAL SAFETY INSTRUCTIONS FOR LASER PRODUCTS..... | 9   |
| 5.4      | RESIDUAL RISK .....                                    | 10  |
| 5.5      | CONNECTION TO THE POWER SUPPLY.....                    | 10  |
| <b>6</b> | <b>TECHNICAL DESCRIPTION</b>                           |     |
| 6.1      | IDENTIFICATION .....                                   | 11  |
| <b>7</b> | <b>UNPACKING AND CHECKING</b>                          |     |
| 7.1      | PACKAGING .....  | 12  |
| 7.2      | WHAT'S IN THE BOX.....                                 | 12  |
| <b>8</b> | <b>PREPARING THE MITRE SAW</b>                         |     |
| 8.1      | TRANSPORTATION .....                                   | 13  |
| 8.2      | RELEASE CATCH .....                                    | 13  |
| 8.3      | SIDE LOCK .....  | 13  |
| 8.4      | BENCH MOUNTING .....                                   | 13  |
| 8.5      | WORKPIECE VICE ASSEMBLY .....                          | 13  |
| 8.6      | ATTACHING THE EXTENSION WINGS .....                    | 14  |
| 8.7      | MITRE TABLE LOCK .....                                 | 14  |
| 8.8      | BEVEL LOCK .....                                       | 15  |
| 8.9      | SETTING THE FENCE SQUARE WITH THE TABLE .....          | 15  |
| 8.10     | SETTING THE 90° ANGLE TO THE BLADE.....                | 16  |
| 8.11     | SETTING THE 45° BEVEL ANGLES TO THE BLADE.....         | 17  |
| 8.12     | THE LASER LINE.....                                    | 17  |
| 8.13     | CHANGING THE BLADE .....                               | 18  |
| <b>9</b> | <b>BASIC COMPOUND MITRE SAW OPERATIONS</b>             |     |
| 9.1      | MAKING A CUT.....                                      | 20  |
| 9.2      | ADJUSTABLE DEPTH STOP.....                             | 20  |
| 9.3      | DUST EXTRACTION.....                                   | 21  |
| 9.4      | MITRE CUT .....  | 21  |
| 9.5      | BEVEL CUT.....   | 21  |
| 9.6      | COMPOUND CUT.....                                      | 21  |
| 9.7      | CUTTING CURVED OR WARPED MATERIAL.....                 | 22  |
| 9.8      | CUTTING CROWN MOULDINGS.....                           | 22  |
| 9.9      | WORKPIECE SUPPORT .....                                | 23  |

## 2. CONTENTS *(continued)*

---

|           |  |          |
|-----------|--|----------|
| <b>10</b> | <b>MAINTENANCE AND TROUBLESHOOTING</b> |          |
| 10.1      | BLADE GUARD.....                       | 24       |
| 10.2      | SAWDUST.....                           | 24       |
| 10.3      | RECOMMENDED ACCESSORIES.....           | 24       |
| 10.4      | PROHIBITED ACCESSORIES.....            | 24       |
| 10.5      | LUBRICATION.....                       | 24       |
| 10.6      | CLEANING.....                          | 24       |
| 10.7      | TROUBLESHOOTING GUIDE.....             | 25       |
| <b>11</b> | <b>OPTIONAL ACCESSORIES</b>            |          |
| 11.1      | OPTIONAL ACCESSORIES.....              | 26       |
| <b>12</b> | <b>DISPOSAL</b>                        |          |
| 12.1      | DISPOSAL.....                          | 27       |
| <b>13</b> | <b>EXPLANATION OF SYMBOLS</b>          |          |
| 13.1      | EXPLANATION OF SYMBOLS.....            | 28       |
|           | <b>DECLARATION OF CONFORMITY</b> ..... | ENCLOSED |

## 3. WARRANTY

---

### 3.1 WARRANTY

Draper tools have been carefully tested and inspected before shipment and are guaranteed to be free from defective materials and workmanship.

Should the tool develop a fault, please return the complete tool to your nearest distributor or contact:

**Draper Tools Limited, Chandler's Ford, Eastleigh, Hampshire, SO53 1YF. England.**

**Telephone Sales Desk: (023) 8049 4333 or:**

**Product Help Line (023) 8049 4344.**

A proof of purchase **must** be provided.

If upon inspection it is found that the fault occurring is due to defective materials or workmanship, repairs will be carried out free of charge. This warranty period covering labour is 12 months from the date of purchase except where tools are hired out when the warranty period is 90 days from the date of purchase. The warranty is extended to 24 months from the date of purchase for parts only. This warranty does not apply to any consumable parts, any type of battery or normal wear and tear, nor does it cover any damage caused by misuse, careless or unsafe handling, alterations, accidents, or repairs attempted or made by any personnel other than the authorised Draper warranty repair agent.

Draper Tools Limited takes pride in the quality of its products and the services offered to our valued customers. As a result we offer a free, 3 year extended warranty for this product.

---

## REGISTER WITHIN 30 DAYS TO CLAIM YOUR

# FREE



\*To register your warranty, visit: [drapertools.com/warranty-registration](http://drapertools.com/warranty-registration)

or call our Customer Help Line on: **(023) 8049 4344**

---

By registering your product you'll automatically become a Draper Club Member where you will have the option to receive news of our new products, offers, deals, competitions and more!

If you are unable to register online, please call our Customer Help Line on the number shown above. Full registration must be completed within 30 days from receipt of purchase. The 3 year extended warranty only applies to permanent UK residents, to the original product purchased from an authorised Draper Tools stockist for use in their appropriate profession/trade. This warranty is not valid to purchasers reselling or hiring the product. This warranty is not transferable and is only available to the original product purchaser who has completed their registration and is a Draper Club Member. The 3 year extended warranty period starts from the date of purchase and is not extended following an inspection, repair or replacement.

Note: If the tool is found not to be within the terms of warranty, repairs and carriage charges will be quoted and made accordingly.

This warranty applies in lieu of any other warranty expressed or implied and variations of its terms are not authorised.

Your Draper warranty is not effective unless you can produce upon request a dated receipt or invoice to verify your proof of purchase within the warranty period.

Please note that this warranty is an additional benefit and does not affect your statutory rights.

**Draper Tools Limited.**

For full terms and conditions visit: [drapertools.com/corporate-policies](http://drapertools.com/corporate-policies)

---

# 4. INTRODUCTION

---

## 4.1 SCOPE

This machine is designed to cut wood; for example, timber frames and roof frames, etc.

It is intended for trade use and has the quality and features to meet and exceed the expectations of the most demanding user. Any application other than that it was designed for is considered misuse.

## 4.2 SPECIFICATION

Stock No .....79899 ..... 79901

Part No ..... SMS255E ..... SMS305E

Motor:

Rated voltage ..... 230V~ ..... 230V~

Rated frequency ..... 50Hz ..... 50Hz

Rated input ..... 2000W ..... 2000W

Revolutions per minute (no load) ..... 5000r/min ..... 5000r/min

Blade diameter ..... 255mm ..... 305mm

Blade thickness ..... 2.4mm ..... 3.0mm

Bore diameter ..... 30mm ..... 30mm

Mitre table angles ..... 0–45° left/right ..... 0–45° left/right

Bevel cut ..... 0–45° left/right ..... 0–45° left/right

Cross cut:

0 × 0°: ..... 90 × 315mm ..... 105 × 340mm

Mitre cut:

45 × 0° (left and right): ..... 90 × 215mm ..... 105 × 235mm

Bevel cut:

0 × 45° (left): ..... 40 × 315mm ..... 60 × 340mm

0 × 45° (right): ..... 38 × 315mm ..... 40 × 340mm

Compound mitre cut:

45° R × 45° (left): ..... 40 × 215mm ..... 60 × 235mm

45° L × 45° (right): ..... 38 × 215mm ..... 40 × 235mm

Sound pressure level (LpA)\*: ..... 94.7dB(A) ..... 90.7dB(A)

Sound power level (LWA)\*\*: ..... 107.7dB(A) ..... 103.7dB(A)

Uncertainty (K): ..... 3dB(A) ..... 3dB(A)

Weight (nett) ..... 17kg ..... 22kg

\* *Continuous A-Weighted Sound Pressure Level at the workstation in accordance to and declared according to EN62841.*

\*\* *The typical A-weighted noise level determined according to EN62841.*

## 4.3 HANDLING AND STORAGE

- Care must be taken when handling this product.
  - Dropping this power tool could have an effect on its accuracy and could also result in personal injury. This product is not a toy and must be respected.
- Environmental conditions can have a detrimental effect on this product if neglected.
  - Exposure to damp air can gradually corrode components.
  - If the product is unprotected from dust and debris, components will become clogged.
  - If not cleaned and maintained correctly or regularly, the machine will not perform at its best.

## 5. HEALTH AND SAFETY INFORMATION

---

### 5.1 GENERAL SAFETY INSTRUCTIONS FOR POWER TOOL USE

When using any type of power tool there are steps that should be taken to make sure that you, as the user, remain safe.

Common sense and a respect for the tool will help reduce the risk of injury.

**Read the instruction manual fully.** Do not attempt any operation until you have read and understood this manual.

Most important you must know how to safely start and stop this machine, especially in an emergency.

**Keep the work area tidy and clean.** Attempting to clear clutter from around the machine during use will reduce your concentration. Mess on the floor creates a trip hazard. Any liquid spilt on the floor could result in you slipping.

**Find a suitable location.** If the machine is bench mounted, the location should provide good natural light or artificial lighting as a replacement. Avoid damp and dust locations as it will have a negative effect on the machine's performance. If the machine is portable do not expose the tool to rain. In all cases do not operate power tools near any flammable materials.

**Keep bystanders away.** Children, onlookers and passers by must be restricted from entering the work area for their own protection. The barrier must extend a suitable distance from the tool user.

**Unplug and house all power tools that are not in use.** A power tool should never be left unattended while connected to the power supply. They must be housed in a suitable location, away locked up and from children. This includes battery chargers.

**Do not overload or misuse the tool.** All tools are designed for a purpose and are limited to what they are capable of doing. Do not attempt to use a power tool (or adapt it in any way) for an application it is not designed for. Select a tool appropriate for the size of the job. Overloading a tool will result in tool failure and user injury. This covers the use of accessories.

**Dress properly.** Loose clothing, long hair and jewellery are all dangerous because they can become entangled in moving machinery. This can also result in parts of body being pulled into the machine. Clothing should be close fitted, with any long hair tied back and jewellery and neck ties removed. Footwear must be fully enclosed and have a non-slip sole.

**Wear personal protective equipment (PPE).** Dust, noise, vibration and swarf can all be dangerous if not suitably protected against. If the work involving the power tool creates dust or fumes wear a dust mask. Vibration to the hand, caused by operating some tools for longer periods must be protected against. Wear vibration reducing gloves and allow long breaks between uses. Protect against dust and swarf by wearing approved safety goggles or a face shield. These are some of the more common hazards and preventions, however, always find out what hazards are associated with the machine/work process and wear the most suitable protective equipment available.

**Do not breathe contaminated air.** If the work creates dust or fumes connect the machine (if possible) to an extraction system either locally or remotely. Working outdoors can also help if possible.

**Move the machine as instructed.** If the machine is hand held, do not carry it by the power supply cable. If the product is heavy, employ a second or third person to help move it safely or use a mechanical device. Always refer to the instructions for the correct method.

**Do not overreach.** Extending your body too far can result in a loss of balance and you falling. This could be from a height or onto a machine and will result in injury.

**Maintain your tools correctly.** A well maintained tool will do the job safely. Replace any damaged or missing parts immediately with original parts from the manufacturer. As applicable, keep blades sharp, moving parts clean, oiled or greased, handles clean, and emergency devices working.

**Wait for the machine to stop.** Unless the machine is fitted with a safety brake, some parts may continue to move due to momentum. Wait for all parts to stop, then unplug it from the power supply before making any adjustments, carrying out maintenance operations or just finishing using the tool.

## 5. HEALTH AND SAFETY INFORMATION

---

**Remove and check setting tools.** Some machinery requires the use of additional tools or keys to set, load or adjust the power tool. Before starting the power tool always check to make certain they have been removed and are safely away from the machine.

**Prevent unintentional starting.** Before plugging any machine in to the power supply, make sure the switch is in the OFF position. If the machine is portable, do not hold the machine near the switch and take care when putting the machine down, that nothing can operate the switch.

**Carefully select an extension lead.** Some machines are not suitable for use with extension leads. If the tool is designed for use outdoors, use an extension lead also suitable for that environment. When using an extended lead, select one capable of handling the current (amps) drawn by the machine in use. Fully extend the lead regardless of the distance between the power supply and the tool. Excess current (amps) and a coiled extension lead will both cause the cable to heat up and can result in fire.

**Concentrate and stay alert.** Distractions are likely to cause an accident. Never operate a power tool if you are under the influence of drugs (prescription or otherwise), including alcohol or if you are feeling tired. Being disorientated will result in an accident.

**Have this tool repaired by a qualified person.** This tool is designed to conform to the relevant international and local standards and as such should be maintained and repaired by someone qualified, using only original parts supplied by the manufacturer. This will ensure the tool remains safe to use.

### 5.2 SAFETY INSTRUCTIONS FOR MITRE SAWS

**Mitre saws are intended to cut wood or wood-like products. They cannot be used with abrasive cut-off wheels for cutting ferrous material such as bars, rods, studs, etc.** Abrasive dust causes moving parts such as the lower guard to jam. Sparks from abrasive cutting will burn the lower guard, the kerf insert and other plastic parts.

**Use clamps to support the workpiece whenever possible. If supporting the workpiece by hand, you must always keep your hand at least 100 mm from either side of the saw blade. Do not use this saw to cut pieces that are too small to be securely clamped or held by hand.** If your hand is placed too close to the saw blade, there is an increased risk of injury from blade contact.

**The workpiece must be stationary and clamped or held against both the fence and the table. Do not feed the workpiece into the blade or cut “freehand” in any way.** Unrestrained or moving workpieces could be thrown at high speeds, causing injury.

**Push the saw through the workpiece. Do not pull the saw through the workpiece. To make a cut, raise the saw head and pull it out over the workpiece without cutting, start the motor, press the saw head down and push the saw through the workpiece.** Cutting on the pull stroke is likely to cause the saw blade to climb on top of the workpiece and violently throw the blade assembly towards the operator.

**Never cross your hand over the intended line of cutting either in front or behind the saw blade.** Supporting the workpiece “cross handed” i.e. holding the workpiece to the right of the saw blade with your left hand or vice versa is very dangerous.

**Do not reach behind the fence with either hand closer than 100 mm from either side of the saw blade, to remove wood scraps, or for any other reason while the blade is spinning.** The proximity of the spinning saw blade to your hand may not be obvious and you may be seriously injured.

**Inspect your workpiece before cutting. If the workpiece is bowed or warped, clamp it with the outside bowed face toward the fence. Always make certain that there is no gap between the workpiece, fence and table along the line of the cut.** Bent or warped workpieces can twist or shift and may cause binding on the spinning saw blade while cutting. There should be no nails or foreign objects in the workpiece.

**Do not use the saw until the table is clear of all tools, wood scraps, etc., except for the workpiece.** Small debris or loose pieces of wood or other objects that contact the revolving blade can be thrown with high speed.



## 5. HEALTH AND SAFETY INFORMATION

**Cut only one workpiece at a time.** Stacked multiple workpieces cannot be adequately clamped or braced and may bind on the blade or shift during cutting.

**Ensure the mitre saw is mounted or placed on a level, firm work surface before use.** A level and firm work surface reduces the risk of the mitre saw becoming unstable.

**Plan your work. Every time you change the bevel or mitre angle setting, make sure the adjustable fence is set correctly to support the workpiece and will not interfere with the blade or the guarding system.** Without turning the tool "ON" and with no workpiece on the table, move the saw blade through a complete simulated cut to assure there will be no interference or danger of cutting the fence.

**Provide adequate support such as table extensions, saw horses, etc. for a workpiece that is wider or longer than the table top.** Workpieces longer or wider than the mitre saw table can tip if not securely supported. If the cut-off piece or workpiece tips, it can lift the lower guard or be thrown by the spinning blade.

**Do not use another person as a substitute for a table extension or as additional support.** Unstable support for the workpiece can cause the blade to bind or the workpiece to shift during the cutting operation pulling you and the helper into the spinning blade.

**The cut-off piece must not be jammed or pressed by any means against the spinning saw blade.** If confined, i.e. using length stops, the cut-off piece could get wedged against the blade and thrown violently.

**Always use a clamp or a fixture designed to properly support round material such as rods or tubing.** Rods have a tendency to roll while being cut, causing the blade to "bite" and pull the work with your hand into the blade.

**Let the blade reach full speed before contacting the workpiece.** This will reduce the risk of the workpiece being thrown.

**If the workpiece or blade becomes jammed, turn the mitre saw off. Wait for all moving parts to stop and disconnect the plug from the power source and/or remove the battery pack; then work to free the jammed material.** Continued sawing with a jammed workpiece could cause loss of control or damage to the mitre saw.

**After finishing the cut, release the switch, hold the saw head down and wait for the blade to stop before removing the cut-off piece.** Reaching with your hand near the coasting blade is dangerous.

**If the machine is equipped with a brake.** Hold the handle firmly when making an incomplete cut or when releasing the switch before the saw head is completely in the down position. The braking action of the saw may cause the saw head to be suddenly pulled downward, causing a risk of injury.

### 5.3 ADDITIONAL SAFETY INSTRUCTIONS FOR LASER PRODUCTS

The laser used in this product is a Class 2 laser with a maximum power of  $\leq 1\text{mW}$  and a wavelength of 650nm.

**Warning!** Avoid direct eye contact with the laser. The laser should not normally present an optical hazard, however, there is a risk of flash blindness when staring directly at the beam.

Please observe the following safety rules:

- The laser must be operated and maintained in accordance to the manufacturer's guidelines and instructions.
- **NEVER** switch the laser guide on until the tool is in the correct cutting position.
- **NEVER** aim the beam into the eyes of any person, animal, or any other object other than the workpiece.

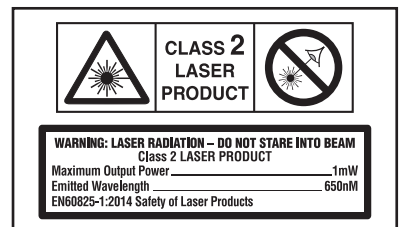

## 5. HEALTH AND SAFETY INFORMATION

---

- Always ensure the laser is aimed at suitable workpiece that has non-reflective surfaces, such as wood or other similar rough-coated surfaces. Reflective metallic surfaces such as sheet steel, or similar, are not suitable as the laser beam guide could be reflected back at the operator.
- **DO NOT** modify or adjust the laser light assembly. Repairs must only be carried out by the manufacturer or an authorised agent. **DO NOT** fit a different type of laser to the product.

**Warning!** Use of controls, adjustments or performance of procedures other than those specified herein could result in hazardous radiation exposure.

Please refer to the relevant EN standards; EN60825-1:2014 for more information on lasers.

### 5.4 RESIDUAL RISK

**Important note:** Although the safety instructions and operating manuals for our tools contain extensive instructions of safe working with power tools, every power tool involves a certain residual risk which can not be completely excluded by safety mechanisms. Power tools must therefore always be operated with caution!

### 5.5 CONNECTION TO THE POWER SUPPLY

**Caution:** Risk of electric shock. Do not open.

This appliance is supplied with a moulded 3 pin mains plug for your safety. The value of the fuse fitted is marked on the pin face of the plug. Should the fuse need replacing, ensure the substitute is of the correct rating, approved to BS1362 and ASTA or BSI Kite marked.

ASTA 

BSI 

The fuse cover is removable with a small plain slot screwdriver. Ensure the fuse cover is replaced before attempting to connect the plug to an electrical outlet. If the cover is missing, a replacement must be obtained or the plug replaced with a suitable type.

If a replacement plug is to be fitted this must be carried out by a qualified electrician.

The damaged or incomplete plug, when cut from the cable should be disabled to prevent connection to a live electrical outlet.

This appliance is Class II<sup>†</sup> and is designed for connection to a power supply matching that detailed on the rating label and compatible with the plug fitted.

If an extension lead is required, use an approved and compatible lead rated for this appliance. Follow all the instructions supplied with the extension lead.

<sup>†</sup>*Double insulated* : This product requires no earth connection as supplementary insulation is applied to the basic insulation to protect against electric shock in the event of failure of the basic insulation.

### IMPORTANT

**If using an extension lead, follow the instructions that came with your lead regarding maximum load while cable is wound. If in doubt, ensure that the entire cable is unwound. Using a coiled extension lead will generate heat which could melt the lead and cause a fire.**

# 6. TECHNICAL DESCRIPTION

## 6.1 IDENTIFICATION

Stock No.79901 shown.

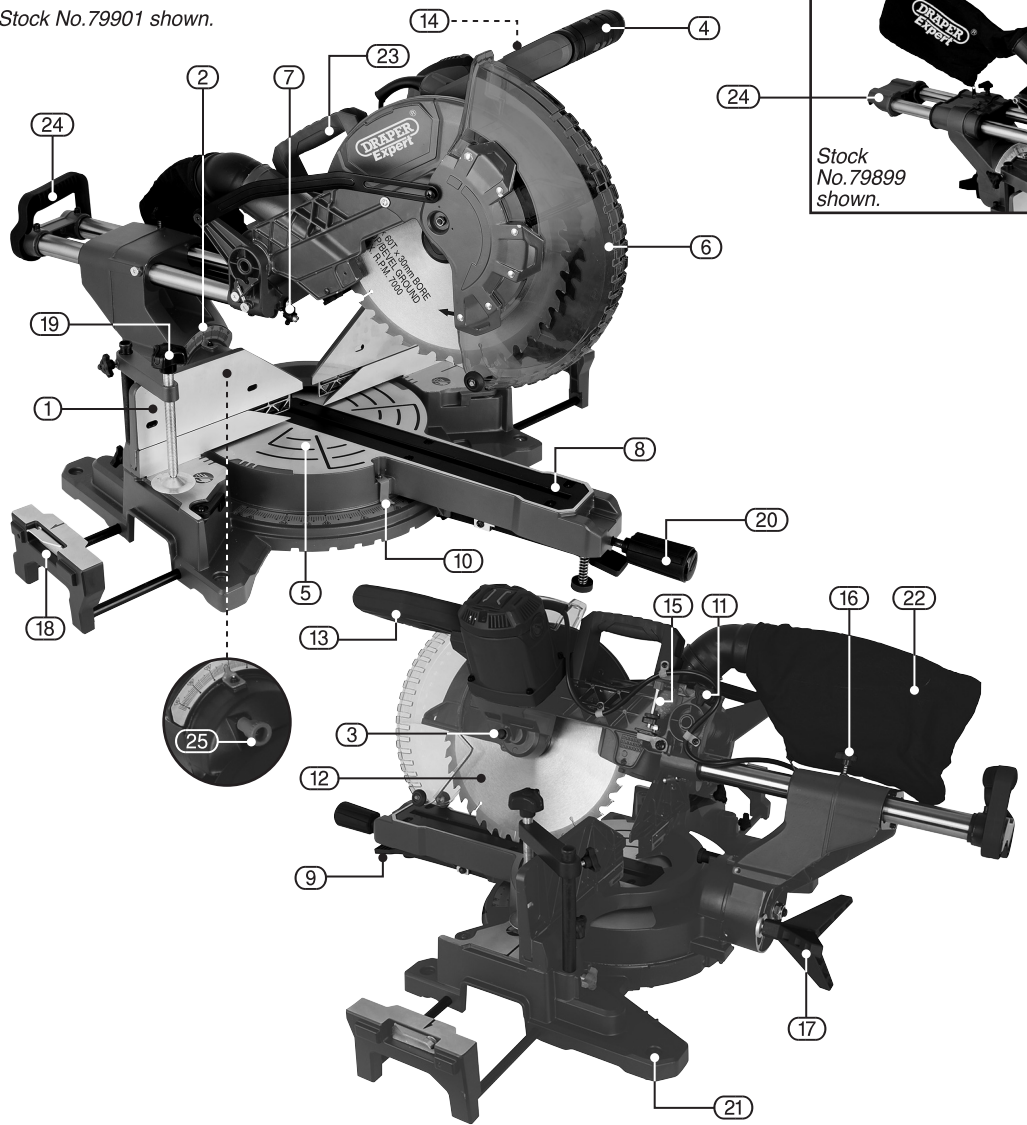

- |                        |                             |                            |
|------------------------|-----------------------------|----------------------------|
| ① Fence.               | ⑩ Miter pointer.            | ⑲ Workpiece vice.          |
| ② Bevel pointer.       | ⑪ Saw head release catch.   | ⑳ Miter locking handle.    |
| ③ Spindle lock button. | ⑫ Blade.                    | ㉑ Work bench mount points. |
| ④ Plunge handle.       | ⑬ On/Off trigger.           | ㉒ Carry handle (top).      |
| ⑤ Table.               | ⑭ Laser On/Off switch.      | ㉓ Carry handle (rear).     |
| ⑥ Lower blade guard.   | ⑮ Adjustable depth stop.    | ㉔ Bevel stop.              |
| ⑦ Laser guide.         | ⑯ Slide lock.               |                            |
| ⑧ Table insert.        | ⑰ Bevel locking knob.       |                            |
| ⑨ Miter latch.         | ⑱ Extending support wings . |                            |

# 7. UNPACKING AND CHECKING

## 7.1 PACKAGING

Carefully remove the product from the packaging and examine it for any sign of damage that may have happened during shipping. Lay the contents out and check them against the parts shown below. If any part is damaged or missing; please contact the Draper Help Line (the telephone number appears on the Title page) and do not attempt to use the product.

The packaging material should be retained at least during the guarantee period: in case the machine needs to be returned for repair.

**Warning!** Some of the packaging materials used may be harmful to children. Do not leave any of these materials in the reach of children.

If any of the packaging is to be thrown away, make sure they are disposed of correctly; according to local regulations.

## 7.2 WHAT'S IN THE BOX

As well as the sliding compound mitre saw, there are several parts not fitted or attached to it.

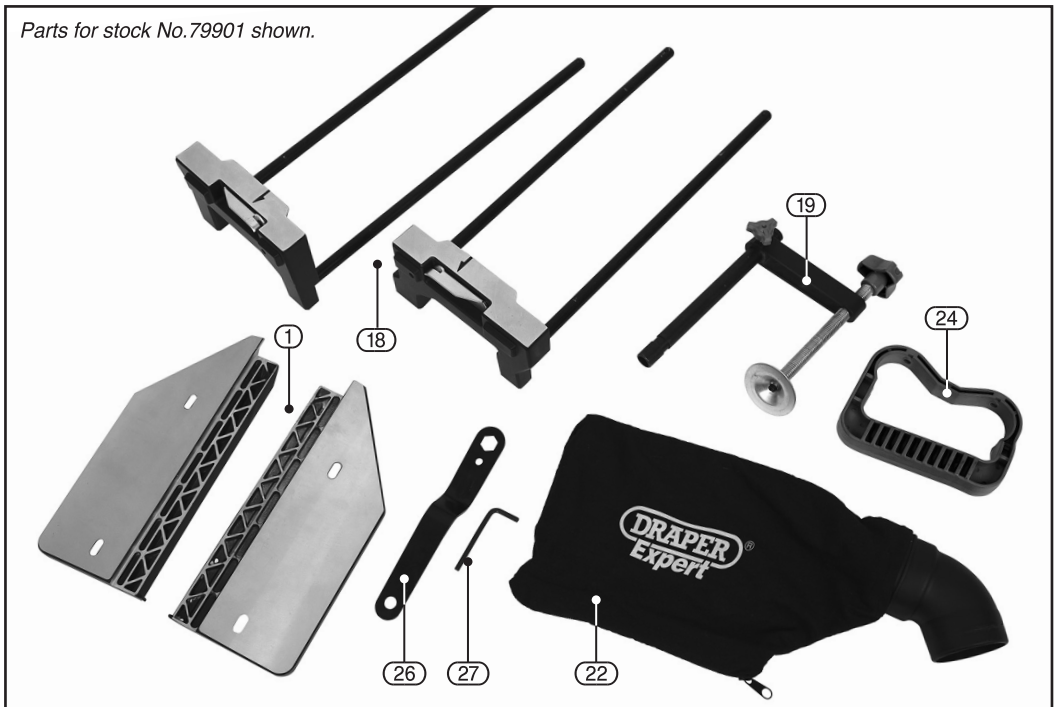

- ① Fence.
- ⑱ Extending support wings.
- ⑲ Workpiece vice.
- ⑳ Dust extraction bag.
- ㉔ Carry handle (rear (Stock No.79901 only)).
- ㉖ Spanner.
- ㉗ Hex. key.

## 8. PREPARING THE COMPOUND MITRE SAW

**Note:** Remove the plug from the socket before carrying out adjustment, servicing or maintenance.

### 8.1 TRANSPORTATION – FIG.1

- Lift the mitre saw only when the saw arm is locked in the down position the sliding mechanism is locked (Fig.3.) and the machine is completely isolated from the power source by unplugging cable or removing battery.
- Only lift the saw by the carrying handles (23) and (24), or outer castings.
- Do not lift the saw using the guard or plunge handle (4).

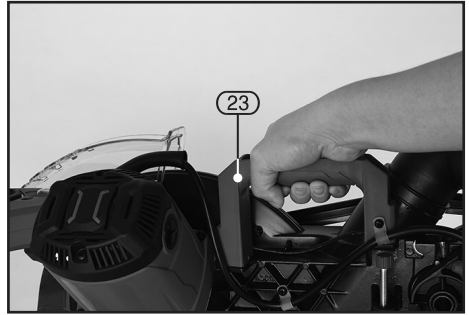

FIG.1

### 8.2 RELEASE CATCH – FIG.2

The release catch (11) is provided for holding the cutting head down whilst transporting or storing the mitre saw. The saw must never be used with the release catch locking the head down.

- Push the saw head down slightly.
- Pull the release catch (11) out.

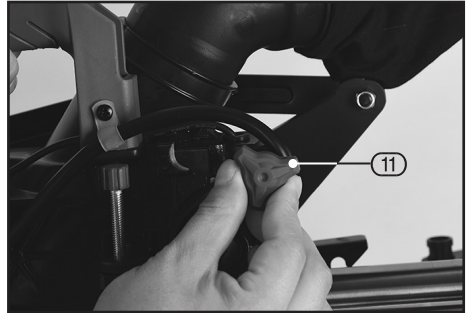

FIG.2

### 8.3 SLIDE LOCK – FIG.3

When tightened, the slide lock (16) prevents the saw head from sliding.

### 8.4 BENCH MOUNTING – FIG.4

**Note:** For safe working practice the saw must be mounted on a secure level surface. The saw base has holes (21) in each corner to facilitate bench mounting.

- Mount the saw to a level, horizontal bench, or work table using 4 bolts (not supplied).
- If desired, you can mount the saw to a piece of 13mm, or thicker, plywood which can then be clamped to your work support or moved to other job sites and re-clamped.

**Caution:** Make sure that the mounting surface is not warped, as an uneven surface can cause binding and inaccurate sawing.

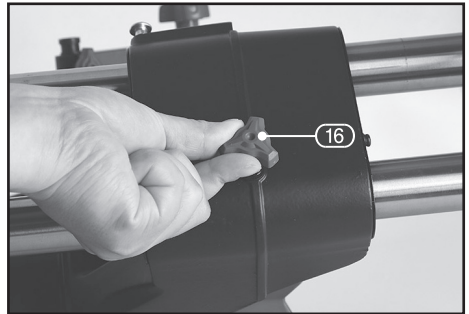

FIG.3

### 8.5 WORKPIECE VICE ASSEMBLY – FIG.5

The clamp assembly (19) can be mounted to the fence, either side of the saw blade to suit the task at hand.

- Use the clamp assembly lock (19.1) at the back of the fence to secure the clamp assembly in position.

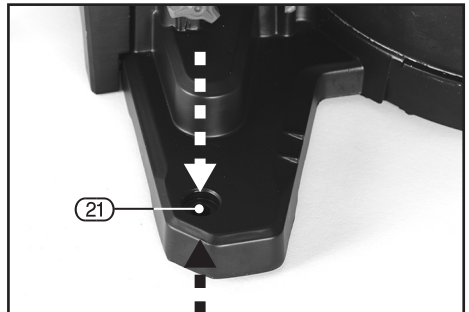

FIG.4

# 8. PREPARING THE COMPOUND MITRE SAW

## 8.6 ATTACHING THE EXTENSION WINGS – FIGS.6 – 7

The extension wings (18) help to support the material when working with long workpieces. There are two location holes for a support bar on either side of the table.

The end stops (18.1) can be secured in place when used, or lowered out of the way to allow longer lengths of wood to be cut.

To attach the extension wings:

### Stock No.79889 (Fig.6):

- Loosen the side support bar locking knobs (28) on the back of the base at the bottom.
- Remove the four screws from the ends of the bars.
- Insert the bars fully into the base and replace the screws.
- The side support bar locking knobs must be tightened to secure the support bars in position.

### Stock No.79901 (Fig.7):

- Open the two levers (29) at the front of the table.
- Remove the four screws from the end of the bars.
- Insert the bars fully into the base and replace the screws.
- Close the two levers when the extension wings are at the desired position.

## 8.7 MITRE TABLE LOCK – FIG.8

The mitre table lock (20) is used to lock the table at the desired mitre angle. The mitre saw cuts from 0° to 45° both left and right. To adjust the mitre angle:

- Loosen the mitre table lock (20) and depress the sprung loaded mitre latch (9) to allow the table to rotate.
- Using the mitre angle pointer (10) to guide you, rotate the table to the desired mitre angle and lock the table in place.
- The mitre table features positive click stops at 0°, 15°, 22.5°, 31.6° and 45° for quick setting of common mitre angles.
- To disengage the click stops, depress the mitre lever and turn to the desired angle.

**Warning!** Be sure to tighten the mitre table lock before making a cut. Failure to do so could result in the table moving during the cut and cause serious personal injury.

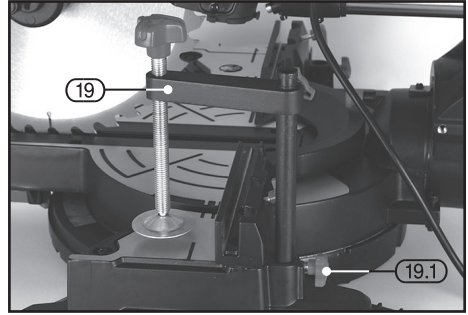

FIG.5

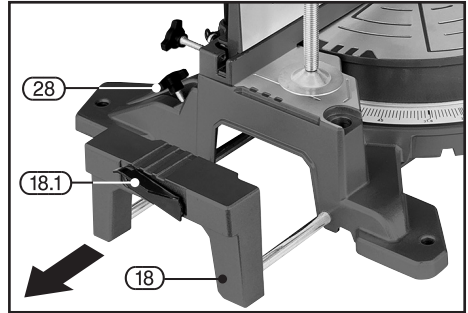

FIG.6

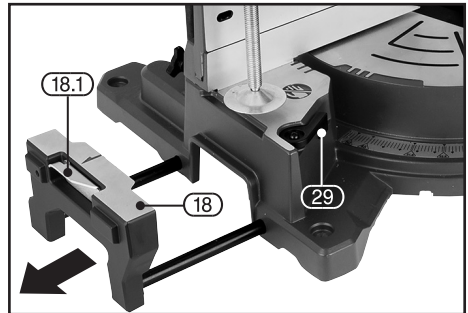

FIG.7

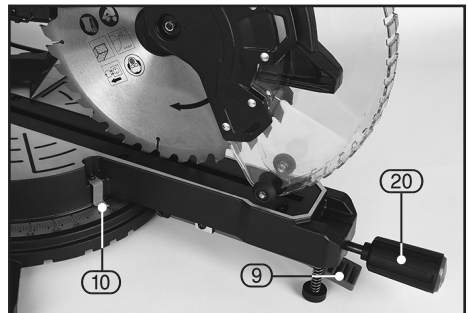

FIG.8

## 8. PREPARING THE COMPOUND MITRE SAW

### 8.8 BEVEL LOCK – FIGS.9 – 10

The bevel lock is used to set the blade at the desired bevel angle. The mitre saw bevel cuts from 0° to 45° to the left and right.

To adjust the bevel angle:

- Loosen the bevel lock (17) and pull out the sprung loaded bevel adjuster (25).
- Adjust the saw arm to the desired bevel angle and re-tighten the bevel lock.

**Warning!** Be sure to tighten the bevel lock before making a cut. Failure to do so could result in the saw arm moving during the cut, causing serious personal injury.

### 8.9 SETTING THE FENCE SQUARE WITH THE TABLE – FIGS.11 – 13

**Note:** Remove the plug from the socket before carrying out adjustment, servicing or maintenance.

- Make sure that the electrical plug is removed from the power point.
- Push the plunge handle (4) down to its lowest position and engage the release catch to hold the saw arm in the transport position.
- Loosen the table lock (20).
- Rotate the table until the pointer (10) is positioned at 0°.
- Tighten the table lock (20).

If the left and right hand upper fences are already attached to the base:

- Using the screw locks (1.1), loosen the upper pieces of the right and left hand side fences (1) and remove these top sections.
- Using the hex. key (27), loosen the four hex. bolts securing the fence to the base.
- Place a set square against the fence and alongside the blade. Be sure the square does not touch the blade teeth.
- Adjust the lower fence until it is square with the blade.
- Re-tighten the hex. bolts securing the lower fence.
- Loosen the cross head screw holding the pointer (10) of the mitre scale and adjust it so that it accurately indicates the zero position on the mitre scale.
- Tighten the screw securing the mitre scale pointer.
- Replace the top sections of the fence and secure.

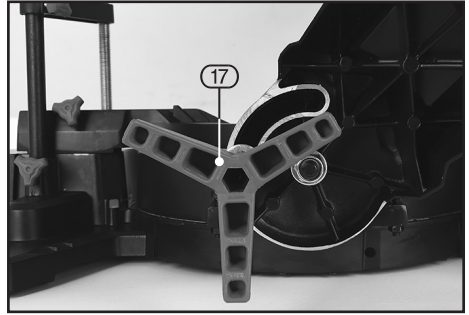

FIG.9

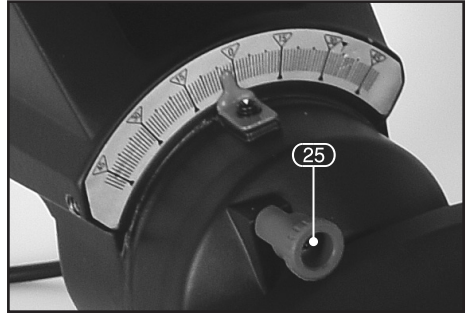

FIG.10

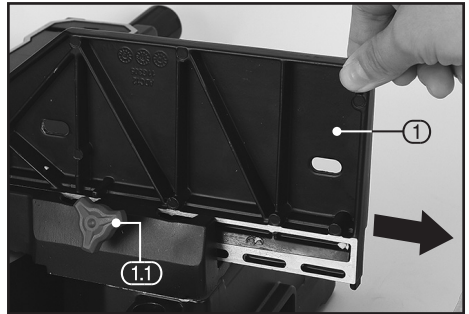

FIG.11



FIG.12

## 8. PREPARING THE COMPOUND MITRE SAW

### 8.10 SETTING THE 90° ANGLE TO THE BLADE – FIGS.14 – 16

**Note:** Remove the plug from the socket before carrying out adjustment, servicing or maintenance.

- Push the plunge handle (4) down to its lowest position and engage the release catch to hold the saw arm in the transport position.
- Loosen the mitre lock.
- Rotate the table until the pointer (10) is positioned at 0°.
- Tighten the mitre lock (20).
- Loosen the bevel lock (17) and set the blade at 90° (the blade 90° to the mitre table).
- Re-tighten the mitre lock.
- Place a set square against the table and the flat part of the blade. Make sure that the square contacts the flat part of the saw blade, not the teeth.
- Rotate the blade by hand and check the blade-to-table alignment at several points.
- The edge of the set square and the saw blade should be parallel.

If the saw blade angles away from the set square, adjust as follows:

- Loosen the bevel locking knob (17). Make sure the bevel stop (25) is pushed in.
- Insert a 4mm hex. key into hole (A) and engage into the grub screw.
- Turn clockwise to move the head to the left.
- Turn anti-clockwise to move the head to the right. Make sure pressure is being applied to the head to keep it against the bevel stop.
- When the blade is flat against the square, remove the hex. key.

Stock No. 79901 has a stop at 33.5° for left side bevels:

- Loosen bevel locking knob (17).
- Make sure the bevel stop (25) is pushed in.
- Tilt the head to the left until it comes up against the stop. Check the angle between the table and the blade using a protractor. Make sure the protractor does not touch the blade teeth.

If adjustment is needed:

- Insert a 4mm hex. key into hole (B) and engage with the grub screw.
- Turn clockwise to move the head to the right.
- Turn anti-clockwise to move the head to the left.



FIG.13



FIG.14

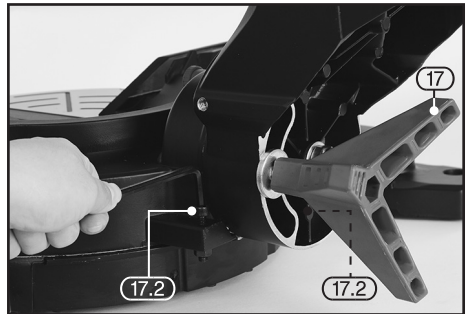

FIG.15

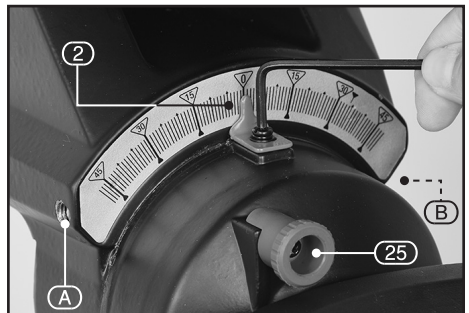

FIG.16



## 8. PREPARING THE COMPOUND MITRE SAW

### 8.11 SETTING THE 45° BEVEL ANGLES TO THE BLADE – FIG.17

**Note:** Remove the plug from the socket before carrying out adjustment, servicing or maintenance.

- Push the plunge handle (4) down to its lowest position and engage the release catch to hold the saw arm in the transport position.
- Loosen the mitre lock.
- Rotate the table until the pointer (10) is positioned at 45°.
- Tighten the mitre lock (20).
- Loosen the bevel lock and set the blade at 45° bevel to the left against the stop.
- Using a protractor, check the angle between the table and the blade. Make sure the protractor is against the body of the blade and not the teeth.
- If adjustment is required, use the spanner (26) to loosen the lock nut on the stop bolt (17.2).
- Using the hex. key (27), adjust the bolt until the angle is correct, then re-tighten the lock nut.
- Check the 45° bevel to the right using the same procedure, as above.

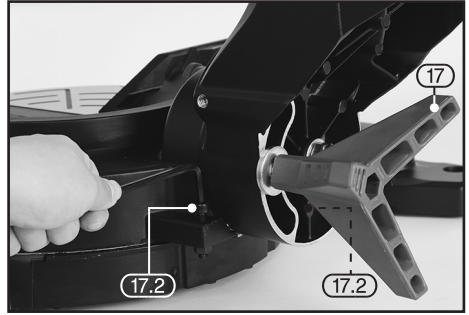

FIG.17

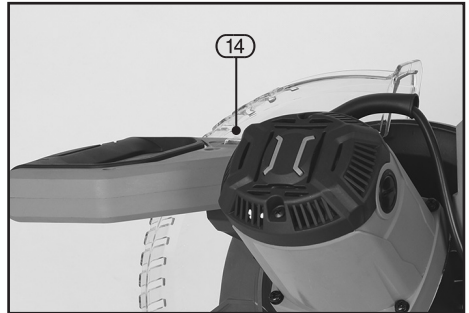

FIG.18

### 8.12 THE LASER LINE – FIGS.18 – 19

The laser is factory set to the centre of the blade width.

**Warning!** Do not stare directly at the laser beam.

**Warning!** Never aim the beam at any person or an object other than the workpiece.

Always ensure the laser beam is aimed at a sturdy workpiece without reflective surfaces. Wood or rough coated surfaces are acceptable. Bright shiny reflective surfaces are not suitable for laser use as the reflective surface could direct the beam back at the operator.

Always remember to switch off the laser on/off switch (14) after finishing a job. Only turn the laser beam on when the workpiece is on the mitre saw table.

- Mark the line of the cut on the workpiece.
- Adjust the angle of mitre and bevel of the cut as required.
- Switch on the laser light on/off switch (14).
- Clamp the workpiece in position using the laser line to align the blade with the pencil mark on the workpiece.
- Make an allowance for the width of the blade.
- When the blade is at its maximum speed (approximately 2 seconds), lower the blade through the workpiece.
- After completing the cut, switch off the laser light on/off switch (14).

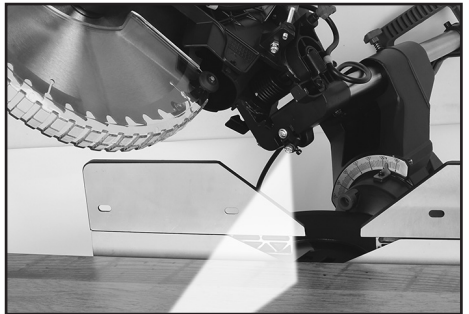

FIG.19

## 8. PREPARING THE COMPOUND MITRE SAW

After each use, clean the laser light assembly (7) as described below:

- Switch off the laser light switch (14) and then remove the plug from the power point.
- With the plunge handle (4) in the raised position, use a soft brush to dust away the sawdust build-up around the assembly.

**Note:** Wear eye protection whilst brushing the dust away.

### 8.13 CHANGING THE BLADE

#### – FIGS.20 – 25

**Note:** Remove the plug from the socket before carrying out adjustment, servicing or maintenance.

**Warning!** Never try to use a blade larger than the stated capacity of the saw. It may come into contact with the blade guards.

**Warning!** Never use a blade that is too thick to allow the outer blade washer to engage with the flats on the spindle. It will prevent the blade screw from properly securing the blade on the spindle.

**Warning!** Do not use the saw to cut metal or masonry. Ensure that any spacers and spindle rings that may be required suit the spindle and the blade fitted.

**Note:** Install the blade with the direction of rotation arrow matching the direction of rotation arrow on the blade guard. The teeth face downward at the front of the saw.

- Raise the plunge handle (4) to its highest position.

**Stock No.79889 (Fig.20):**

- Using a cross head screwdriver, loosen and remove the screw (6.2) that secures the front of the lower guard pivot plate.
- Turn the pivot plate anti-clockwise while rotating the lower guard anti-clockwise.

**Stock No.79901 (Fig.21):**

- Rotate the lower guard (6) to the open position.
- Using the hex. key (27), loosen and remove the bolt that secures the front of the lower guard pivot plate (6.1).
- Turn the plate anti-clockwise.

**Stock No's.79889 & 79901 (Figs.22 – 25):**

- Press the spindle lock button (3). Rotate the blade until the spindle locks.
- Use the hex. key (27) to loosen and remove the blade bolt (12.1). (Loosen in a clockwise direction as the blade screw has a left hand thread).

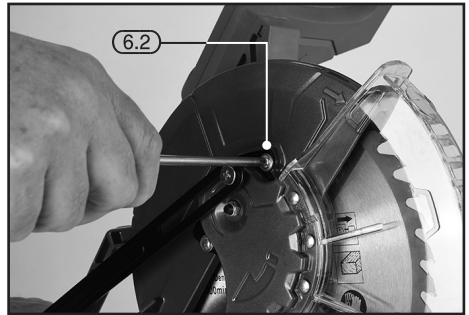

FIG.20

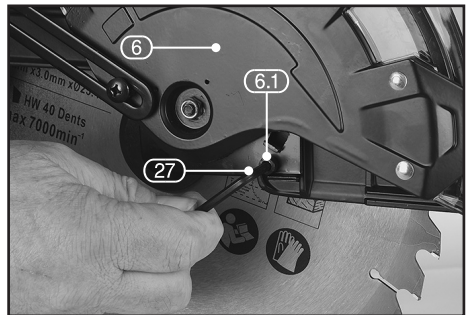

FIG.21



FIG.22

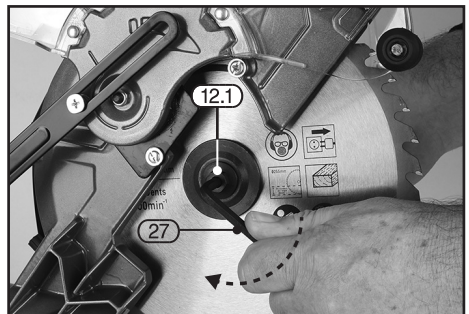

FIG.23

## 8. PREPARING THE COMPOUND MITRE SAW

- Remove the flat washer and outer blade washer and the blade.
- Wipe a drop of oil onto the inner blade washer and the outer blade washer where they contact the blade.
- Fit the new blade onto the spindle taking care that the inner blade washer sits behind the blade.

**Caution:** To ensure correct blade rotation, always install the blade with the blade teeth and the arrow printed on the side of the blade pointing down. The direction of blade rotation is also stamped with an arrow on the upper blade guard.

- Replace the outer blade washer.
- Depress the spindle lock button (3) and replace the flat washer and blade bolt (12.1).
- Use the hex. key (27) to tighten the blade bolt securely (tighten in an anti-clockwise direction).

### Stock No.79889:

- Rotate the lower guard pivot plate clockwise and then lower the blade guard. Refit the screw.

### Stock No.79901:

- Rotate the lower guard pivot plate clockwise and re-fit the bolt.
- Rotate the lower blade guard clockwise to the closed position.

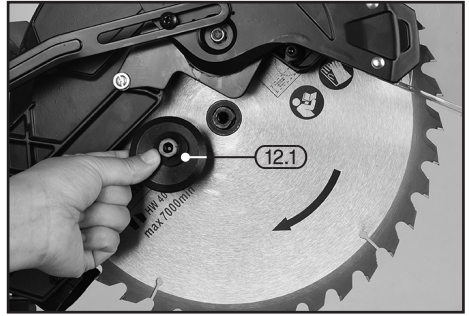

FIG.24



FIG.25

# 9. BASIC COMPOUND MITRE SAW OPERATIONS

## 9.1 MAKING A CUT – FIG.26

The mitre saw is fitted with a safety switch to prevent accidental starting.

- If sliding mechanism is required saw must be slid towards user before switching saw on. Cut must then be made by sliding away from you to avoid unexpected catching on workpiece and potential injury.
- Hold the plunge handle (4) and slide the lever (13.1) located in the centre of the trigger switch (13) to the left.

Squeeze the switch trigger (13). Allow the blade to reach maximum speed.

- Slowly lower the blade into and through the workpiece.
- Release the trigger switch (13) and allow the saw blade to stop rotating before raising the blade out of the workpiece. Wait until the blade stops before removing the workpiece.

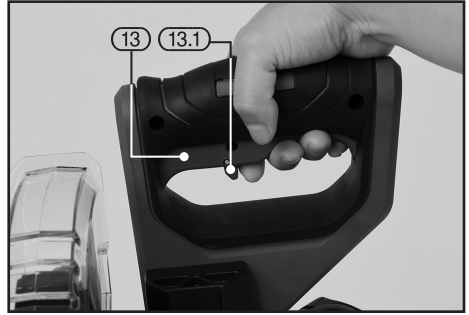

FIG.26

## 9.2 ADJUSTABLE DEPTH STOP – FIGS.27 – 28

**Stock No.79889 (Fig.27):**

- The depth of cut screw (15.1) is pre-set by the factory.
- Make sure the depth stop (15.2) is pushed to the rear when the workpiece needs to be cut all the way through.
- If a different depth of cut is required, raise the head to its uppermost position. Pull the depth stop (15.2) forward, loosen lock nut (15.3) and adjust the depth adjustment screw (15) to the required position.
- Tighten the locking nut. Make a test cut to check the depth of cut.
- To return to normal operation, move the depth stop to the rear.

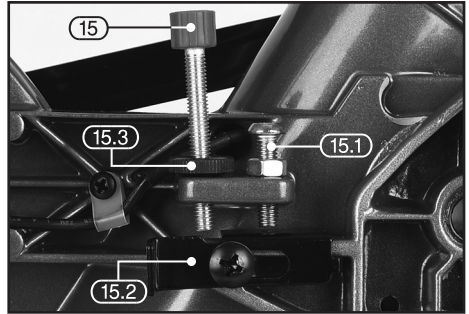

FIG.27

**Stock No.79901 (Fig.28):**

- The principal is the same as for Stock No.79889, except the depth stop (15.2) should be in the vertical position for normal use and in the horizontal position for adjustable depths of cut.

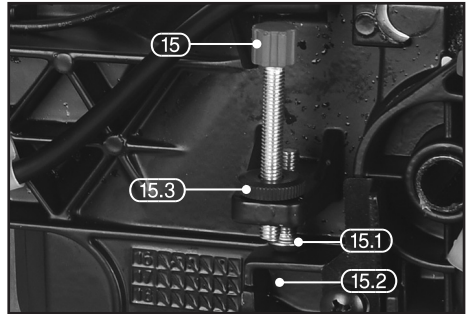

FIG.28

# 9. BASIC COMPOUND MITRE SAW OPERATIONS

## 9.3 DUST EXTRACTION – FIG.29

The saw comes supplied with a cloth dust bag (22). Empty the dust bag regularly or when full. When cutting large pieces of material or cutting for a longer period, exchange the dust bag with a vacuum cleaner to allow more efficient removal of harmful airborne dust particles. It may be necessary to source an appropriate adaptor to adjust the dust outlet size to suit the vacuum hose.

**Note:** A suitable dust mask must be worn for any cutting operations.

## 9.4 MITRE CUT – FIG.30

When a mitre cut is required:

- Loosen the mitre locking handle (20).
- Depress the mitre latch (9) and move the saw to the desired angle.

Do not stand in front of the saw table. Move with the handle to the mitre angle to make the cut.

## 9.5 BEVEL CUT – FIG.31

When a bevel cut is required:

- Loosen the bevel lock (17).
- Pull out the stop button (17.1) and tilt the saw head to the desired angle and tighten the bevel lock.
- Tilt the blade to the desired bevel angle. Stand to the left side of the handle to make the cut.

## 9.6 COMPOUND CUT – FIG.32

When a compound cut is required, select the correct bevel and mitre position. Move with the handle to the mitre angle to make the cut.



FIG.29

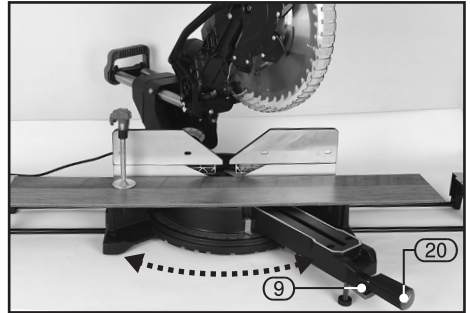

FIG.30

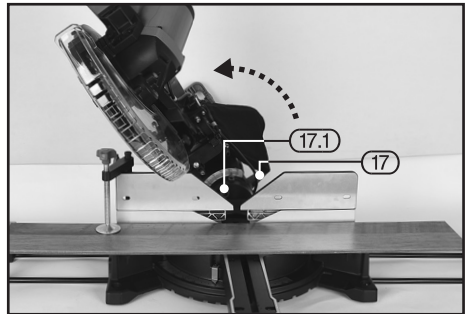

FIG.31

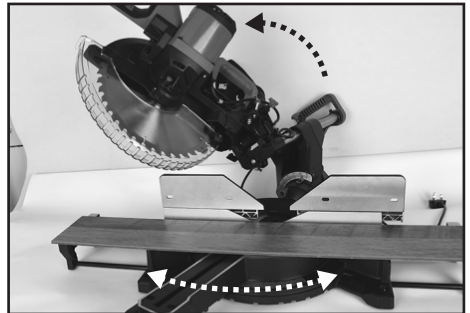

FIG.32

## 9. BASIC COMPOUND MITRE SAW OPERATIONS

### 9.7 CUTTING CURVED OR WARPED MATERIAL – FIGS.33 – 34

Before cutting a workpiece, check to make sure it is flat. If it is curved or warped, the workpiece must be positioned and cut as illustrated.

- Do not position workpiece incorrectly or try to cut the workpiece without the support of the fence. This will cause pinching of the workpiece on the blade.
- The workpiece could suddenly jump or move and your hand could hit the blade.

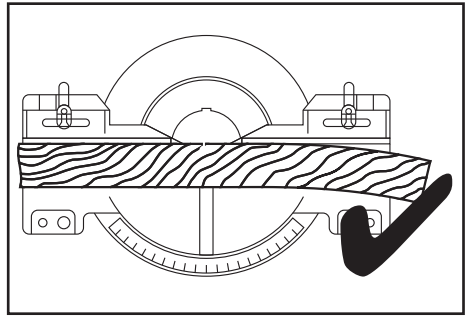

FIG.33

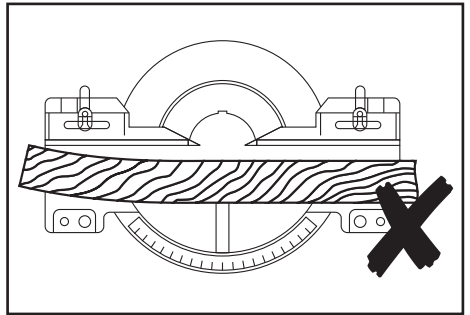
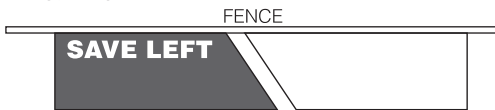

FIG.34

### 9.8 CUTTING CROWN MOULDINGS

**To cut an inside corner:**

- Cut the left side by aligning the **top of the moulding against the fence.**
- Set the bevel to 33.9°
- Set the mitre to 31.6° to the **right hand side.**
- Make the cut and **save the piece to the left of the cut line.**



**To cut an outside corner:**

- Cut the left side by aligning the **bottom of the moulding against the fence.**
- Set the bevel to 33.9°
- Set the mitre to 31.6° to the **left hand side.**
- Make the cut and **save the piece to the right of the cut line.**

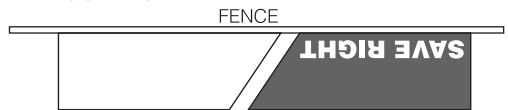

**To cut the right side:**

- Align the **bottom of the moulding against the fence.**
- Set the bevel to 33.9°
- Set the mitre to 31.6° to the **left hand side.**
- Make your cut and again **save the piece to the left of the cut line.**



**To cut the left side:**

- Align the **top of the moulding against the fence.**
- Set the bevel to 33.9°
- Set the mitre to 31.6° to the **right hand side.**
- Make your cut and again **save the piece to the right of the cut line.**

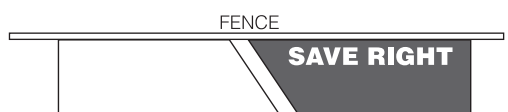

## 9. BASIC COMPOUND MITRE SAW OPERATIONS

---

### 9.9 WORKPIECE SUPPORT – FIG.35

Long workpieces need extra support during cutting.

- Extra support must be placed under the workpiece so the workpiece does not sag and the hand holding the workpiece is positioned 4" or more from the blade path.
- The support must let the workpiece lay flat on the machine table and be worktable during the cutting operation.

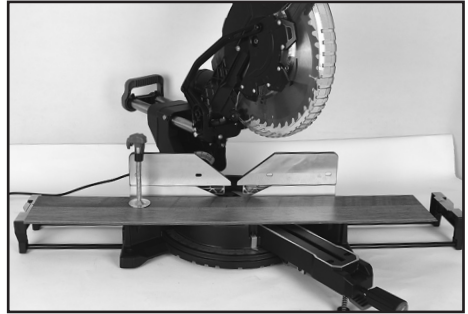

FIG.35

# 10. MAINTENANCE AND TROUBLESHOOTING

---

Regular inspection and cleaning reduces the necessity for maintenance operations and will keep your tool in good working condition.

The motor must be correctly ventilated during tool operation. For this reason avoid blocking the air inlets. After use disconnect the tool from the power supply and vacuum the ventilation slots.

If the replacement of the supply cord is necessary, this has to be done by the manufacturer or his agent in order to avoid a safety hazard.

Always unplug the power cable before any maintenance check on this saw.

**Danger!** Never put lubricants on the blade whilst it is spinning.

**Warning!** To avoid injury from unexpected starting or electrical shock, unplug the power cable before working on the saw.

**Warning!** For your safety, this saw is double insulated. To avoid electrical shock, fire or injury, use only parts identical to those identified in the parts list, reassemble exactly as original assembly to avoid electrical hazards.

## 10.1 BLADE GUARD

Do not use the saw without the lower guard. The lower blade guard is attached to the saw for protection. Should the lower guard become damaged, do not use the saw until damaged guard has been replaced. Develop a regular check to make sure the lower guard is working properly. Clean the lower guard of any dust or build up with a damp cloth, with the power supply disconnected.

**Caution! DO NOT use solvents on the guard.** They could make the plastic 'cloudy' and brittle.

**Warning!** When cleaning lower guard, unplug the saw from the outlet to avoid unexpected start-up or electrical shock.

## 10.2 SAWDUST

Periodically, sawdust will accumulate under the worktable, base and around the switch mechanisms. This could cause difficulty in the movement of the worktable when setting up a mitre cut or switching operations. Frequently vacuum up the sawdust.

## 10.3 RECOMMENDED ACCESSORIES

**Warning!** To avoid injury from unsafe accessories, use only Draper accessories.

## 10.4 PROHIBITED ACCESSORIES

The use of any cutting tool except saw blades which meet the requirement under recommended accessories is prohibited. Do not use accessories such as shaper cutters or dado sets. Ferrous and non-ferrous metal cutting and the use of abrasive wheels are prohibited.

## 10.5 LUBRICATION

All the motor bearings in this tool are lubricated with a sufficient amount of high grade lubricant for the life of the unit under normal operating conditions, therefore, no further lubrication is required.

All the ball bearings are sealed and lubricated for life and will require no maintenance.

## 10.6 CLEANING

After use, wipe off chips and dust adhering to the tool with a cloth or the like. Keep the blade guard clean. Lubricate the sliding portions with machine oil to prevent rust.

To maintain product SAFETY and RELIABILITY, repairs and, any other maintenance or adjustment should be performed by your nearest authorised service centre.



# 10. MAINTENANCE AND TROUBLESHOOTING

## 10.7 TROUBLESHOOTING GUIDE

**Note:** Remove the plug from the socket before carrying out adjustment, servicing or maintenance.

| <b>Problem</b>                    | <b>Possible Cause</b>   | <b>Remedy</b>   |
|-----------------------------------|---|---|
| Motor does not start.             | <ol style="list-style-type: none"><li>1. Fuse.</li><li>2. Brushes worn.</li><li>3. Other.</li></ol>   | <ol style="list-style-type: none"><li>1. Replace the fuse.</li><li>2. Have brushes replaced by an authorised service agent.</li><li>3. Contact an authorised service agent.</li></ol>   |
| Sliding action stiff or binding.  | <ol style="list-style-type: none"><li>1. Slide lock engaged.</li><li>2. Build up of sawdust</li></ol>   | <ol style="list-style-type: none"><li>1. Loosen slide lock.</li><li>2. Vacuum up sawdust and lubricate mechanism.</li></ol>   |
| Poor cutting performance.         | <ol style="list-style-type: none"><li>1. Saw blade blunt.</li><li>2. Saw blade incorrectly mounted.</li><li>3. Incorrect saw blade selection.</li></ol> | <ol style="list-style-type: none"><li>1. Stop machine immediately. Replace saw blade.</li><li>2. Stop machine immediately. Remove and refit saw blade as per instructions.</li><li>3. Seek advice on suitable saw blades.</li></ol> |
| Saw vibrates                      | <ol style="list-style-type: none"><li>1. Saw blade distorted.</li><li>2. Saw blade incorrectly mounted.</li></ol>                                       | <ol style="list-style-type: none"><li>1. Stop machine immediately and replace blade.</li><li>2. Stop machine immediately. Remove and refit saw blade as per instructions.</li></ol>   |
| Mitre position difficult to move. | Build up of sawdust under table.  | Vacuum up sawdust.  |

# 11. OPTIONAL ACCESSORIES

---

## 11.1 OPTIONAL ACCESSORIES

A full range of accessories are available from Draper Tools.

Please visit our website for details: [www.drapertools.com](http://www.drapertools.com)

# 12. DISPOSAL

---

## 12.1 DISPOSAL

- At the end of the machine's working life, or when it can no longer be repaired, ensure that it is disposed of according to national regulations.
- Contact your local authority for details of collection schemes in your area.

In all circumstances:

- Do not dispose of power tools with domestic waste.
- Do not incinerate.
- Do not dispose of WEEE\* as unsorted municipal waste.



\* *Waste Electrical & Electronic Equipment.*

# 13. EXPLANATION OF SYMBOLS

---

## 13.1 EXPLANATION OF SYMBOLS



Read the instruction manual.



Wear face mask and safety glasses.



Wear ear defenders.



Wear protective gloves.



Do not abandon into the environment.



Keep out of the reach of children.



**Warning!**



Class II construction  
*(Double insulated).*



WEEE –  
Waste Electrical &  
Electronic Equipment.  
*Do not dispose of Waste Electrical  
& Electronic Equipment in with  
domestic rubbish.*



**Warning!**  
Class 2 laser product





# NOTES

---



# CONTACTS

Draper Tools Limited, Hursley Road,  
Chandler's Ford, Eastleigh, Hampshire. SO53 1YF. U.K.

Help line: (023) 8049 4344

Sales Desk: (023) 8049 4333

Internet: [drapertools.com](http://drapertools.com)

E-mail: [sales@drapertools.com](mailto:sales@drapertools.com)

General Enquiries: (023) 8026 6355

Service/Warranty Repair Agent:

For aftersales servicing or warranty repairs, please contact the Draper Tools Help line for details of an agent in your local area.

YOUR DRAPER STOCKIST

TACH0819

©Published by Draper Tools Limited.

No part of this publication may be reproduced, stored in a retrieval system or transmitted in any form or by any means, electronic, mechanical photocopying, recording or otherwise without prior permission in writing from Draper Tools Ltd.