

5547

# LASER<sup>®</sup>

## Glow Plug Aperture Cleaner - M8 | M9



[www.lasertools.co.uk](http://www.lasertools.co.uk)

5547

# LASER<sup>®</sup>

## Glow Plug Aperture Cleaner - M8 | M9



[www.lasertools.co.uk](http://www.lasertools.co.uk)

### Caution

- Always wear gloves, safety goggles and safety boots.
- Always tighten components to the manufacturers recommended torque settings.
- The Tool Connection Ltd cannot accept any responsibility for damage to the engine or personnel through use of this tool however used.



### Guarantee

If this product fails through faulty materials or workmanship, contact our service department direct on: **+44 (0) 1926 818186**. Normal wear and tear are excluded as are consumable items and abuse.



Distributed by The Tool Connection Ltd

Kineton Road, Southam, Warwickshire CV47 0DR  
T +44 (0) 1926 815000 F +44 (0) 1926 815888  
info@toolconnection.co.uk [www.toolconnection.co.uk](http://www.toolconnection.co.uk)

### Caution

- Always wear gloves, safety goggles and safety boots.
- Always tighten components to the manufacturers recommended torque settings.
- The Tool Connection Ltd cannot accept any responsibility for damage to the engine or personnel through use of this tool however used.



### Guarantee

If this product fails through faulty materials or workmanship, contact our service department direct on: **+44 (0) 1926 818186**. Normal wear and tear are excluded as are consumable items and abuse.



Distributed by The Tool Connection Ltd

Kineton Road, Southam, Warwickshire CV47 0DR  
T +44 (0) 1926 815000 F +44 (0) 1926 815888  
info@toolconnection.co.uk [www.toolconnection.co.uk](http://www.toolconnection.co.uk)

## Glow Plug Aperture Cleaner - M8 | M9

When glow plugs (diesel heater plugs) require replacing it is best practice to properly clean out the glow plug aperture within the cylinder head particularly around the area of the glow plug heater element tip.

This kit has been designed to offer an adjustable cleaning solution for M8 and M9 glow plug aperture, for use where the original glow plugs have been removed successfully.

Not suitable for drilling out or extracting broken glow plugs.

### Instructions for use:

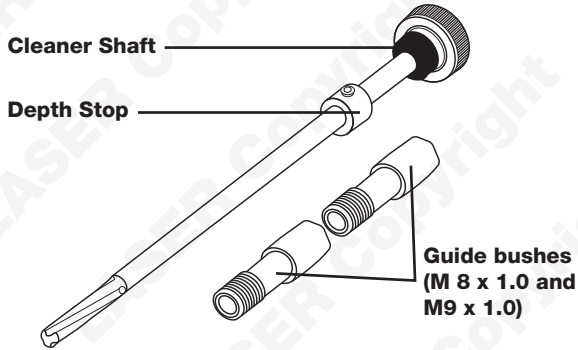

1. Identify the appropriate threaded guide bush by matching the threads to the new glow plug
2. Slide the depth stop onto the cleaning shaft followed by the appropriate threaded guide
3. By comparing the length of the new glow plug to the assembled tool, set the cleaner length so that the tip of the cleaner shaft matches the length of the glow plug and tighten the grub screw in the depth stop.

## Glow Plug Aperture Cleaner - M8 | M9

When glow plugs (diesel heater plugs) require replacing it is best practice to properly clean out the glow plug aperture within the cylinder head particularly around the area of the glow plug heater element tip.

This kit has been designed to offer an adjustable cleaning solution for M8 and M9 glow plug aperture, for use where the original glow plugs have been removed successfully.

Not suitable for drilling out or extracting broken glow plugs.

### Instructions for use:

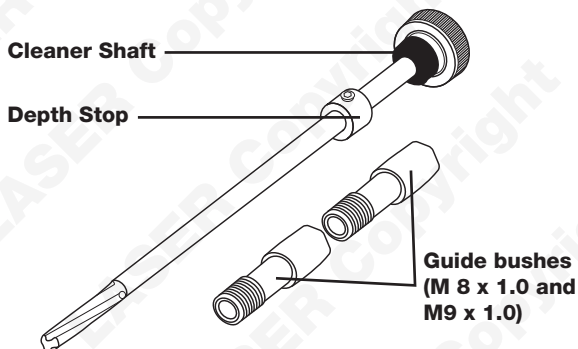

1. Identify the appropriate threaded guide bush by matching the threads to the new glow plug
2. Slide the depth stop onto the cleaning shaft followed by the appropriate threaded guide
3. By comparing the length of the new glow plug to the assembled tool, set the cleaner length so that the tip of the cleaner shaft matches the length of the glow plug and tighten the grub screw in the depth stop.

### Instructions for use:

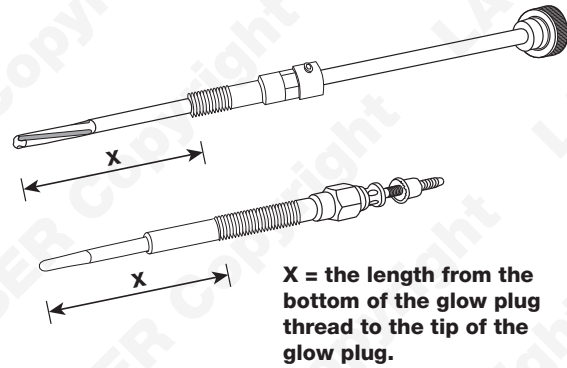

4. Ensure the glow plug aperture threads are clean and free from debris before fitting the threaded guide into the aperture.
5. Slide the threaded guide off and screw it carefully into the glow plug aperture.
6. Fill the flutes of the cleaning shaft with clean grease and insert into the threaded guide whilst turning the shaft in a clockwise direction.
7. Continue to turn the cleaning shaft until the stop touches the top of the threaded guide.
8. Continue turning the cleaner shaft in a clockwise direction as the shaft is removed.

#### Note:

Whilst the use of grease on the cleaner shaft will help any dirt and carbon to stick to the shaft it cannot be guaranteed that carbon will not drop into the cylinder. To further help prevent this it is advised that the injectors be removed and a suitable air adaptor fitted so compressed air can be forced into the cylinder which will in turn help push any loose carbon deposits out of the glow plug aperture.

### Instructions for use:

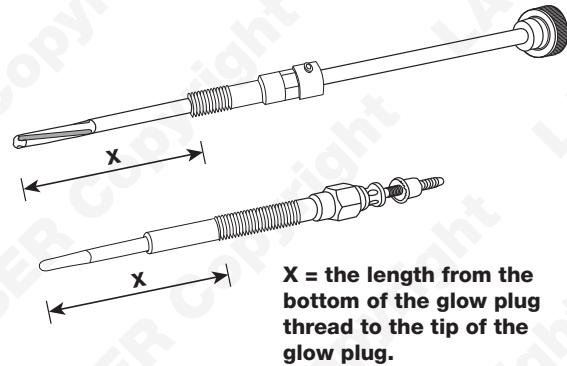

4. Ensure the glow plug aperture threads are clean and free from debris before fitting the threaded guide into the aperture.
5. Slide the threaded guide off and screw it carefully into the glow plug aperture.
6. Fill the flutes of the cleaning shaft with clean grease and insert into the threaded guide whilst turning the shaft in a clockwise direction.
7. Continue to turn the cleaning shaft until the stop touches the top of the threaded guide.
8. Continue turning the cleaner shaft in a clockwise direction as the shaft is removed.

#### Note:

Whilst the use of grease on the cleaner shaft will help any dirt and carbon to stick to the shaft it cannot be guaranteed that carbon will not drop into the cylinder. To further help prevent this it is advised that the injectors be removed and a suitable air adaptor fitted so compressed air can be forced into the cylinder which will in turn help push any loose carbon deposits out of the glow plug aperture.