

**HONDA**  
POWER PRODUCTS

**HONDA**  
The Power of Dreams

# POWER CARRIER HP500H

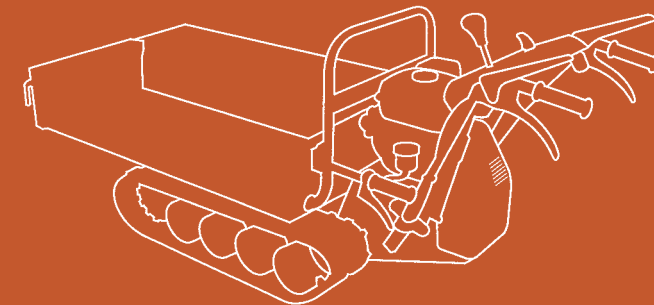

**OWNER'S MANUAL  
MANUEL DE L'UTILISATEUR  
BEDIENUNGSANLEITUNG  
MANUAL DE EXPLICACIONES  
MANUALE DELL'UTENTE**

36776630  
00X36-776-6300

**KS**

© Honda Motor Co., Ltd. 2012  
K2  
英 仏 独 西 伊 中 (FM) 400.2012.06  
Printed in China

DIC  
238 Bk

背幅8mm

HP500H\_OM表紙\_36776630

# Honda HP500H

**OWNER'S MANUAL**  
Original instructions

**MANUEL DE L'UTILISATEUR**  
Notice originale

**BEDIENUNGSANLEITUNG**  
Originalbetriebsanleitung

**MANUAL DE EXPLICACIONES**  
Manual original

**MANUALE DELL'UTENTE**  
Istruzioni originali



ECOLOGY CONSCIOUS TECHNOLOGY

The "e-SPEC" mark symbolizes environmentally responsible technologies applied to Honda power equipment, which contains our wish to "preserve nature for generations to come."

Thank you for purchasing a Honda POWER CARRIER.

This manual covers the operation and maintenance of the Honda POWER CARRIER: HP500H.

All information in this publication is based on the latest production information available at the time of printing.

Honda Motor Co., Ltd. reserves the right to make changes at any time without notice and without incurring any obligation.

No part of this publication may be reproduced without written permission.

This manual should be considered a permanent part of the power carrier and should remain with it if it is resold.

Pay special attention to statements preceded by the following words:

**▲WARNING** Indicates a strong possibility of severe personal injury or death if instructions are not followed.

**CAUTION:** Indicates a possibility of personal injury or equipment damage if instructions are not followed.

**NOTE:** Gives helpful information.

If a problem should arise, or if you have any questions about the power carrier, consult an authorized Honda dealer.

**▲WARNING**  
Honda power carrier is designed to give safe and dependable service if operated according to instructions. Read and understand the Owner's Manual before operating the power carrier. Failure to do so could result in personal injury or equipment damage.

- The illustration may vary according to the type.

---

**Disposal**

To protect the environment, do not dispose of this product, battery, engine oil, etc. carelessly by leaving them in the waste. Observe the local laws and regulations or consult your authorized Honda dealer for disposal.

## CONTENTS

---

1. SAFETY INSTRUCTIONS .....	3
2. SAFETY LABEL LOCATIONS.....	5
CE mark and noise label locations.....	6
3. COMPONENT IDENTIFICATION .....	7
4. CONTROLS .....	8
5. PRE-OPERATION CHECKS .....	13
6. STARTING THE ENGINE .....	19
•High altitude operation .....	22
7. OPERATION.....	23
8. CARRYING LOADS .....	25
9. STOPPING THE ENGINE .....	31
10. MAINTENANCE.....	34
11. TRANSPORTING/STORAGE .....	49
12. TROUBLESHOOTING .....	52
13. SPECIFICATIONS .....	53
MAJOR Honda DISTRIBUTOR ADDRESSES .....	Inside back cover
“EC Declaration of Conformity” CONTENT OUTLINE....	Inside back cover

# 1. SAFETY INSTRUCTIONS

## ▲WARNING

To ensure safe operation—



- Honda power carrier is designed to give safe and dependable service if operated according to instructions. Read and understand the Owner's Manual before operating the power carrier. Failure to do so could result in personal injury or equipment damage.



- Exhaust contains poisonous carbon monoxide, a colorless, odorless gas. Breathing carbon monoxide can cause loss of consciousness and may lead to death.
- If you run the power carrier in an area that is confined, or even partially enclosed area, the air you breathe could contain a dangerous amount of exhaust gas.
- Never run your power carrier inside a garage, house, or near open windows or doors.



- Stop the engine before refueling.
- Gasoline is extremely flammable and explosive under certain conditions. Refuel in a well ventilated area with the engine stopped.



- A hot exhaust system can cause serious burns. Avoid contact if the engine has been running.

- Be careful not to spill fuel when refueling. Fuel vapor or spilled fuel may ignite. If any fuel is spilled, make sure the area is dry before starting the engine.
- Never run the engine in an enclosed or confined area. Exhaust contains poisonous carbon monoxide gas; exposure may cause loss of consciousness and may lead to death.

**▲WARNING**

To ensure safe operation–

- The muffler becomes very hot during operation and remains hot for a while after stopping the engine. Be careful not to touch the muffler while it is hot. To avoid severe burns or fire hazards, let the engine cool before transporting the power carrier or starting it indoors.
- Always make a pre-operation inspection (page 13) before you start the engine. You may prevent an accident or equipment damage.
- Keep children and pets away from the area of operation to avoid possible injury from contact with the power carrier.
- To avoid accidents or loss of control, do not ride on the power carrier; walk behind, and hold both handlebars firmly. Do not allow others to ride on the power carrier as passengers.
- Watch for obstacles while operating the power carrier. Do not use the power carrier when visibility is poor. Under conditions of poor visibility, there is a greater risk of striking an obstacle.
- To avoid accidents or overturning, observe the load limits described on page 29.  
Be sure the load is secure and does not protrude from the power carrier or block visibility.
- To avoid overturning, be careful when changing the direction of the power carrier while operating it on slopes, and do not operate the power carrier on upward slopes greater than 25° (46%) or downward slopes greater than 15° (26%).
- When operating the power carrier in reverse and walking backward, there is a greater risk of slipping or tripping. Be especially careful when backing up.
- Know how to stop the power carrier quickly, and understand the operation of all controls. Never permit anyone to operate the power carrier without proper instruction.
- Never use this unit for nighttime work.

## 2. SAFETY LABEL LOCATIONS

This label warns you of potential hazards that can cause serious injury. Read the labels and safety notes and precautions described in this manual carefully.

If a label comes off or becomes hard to read, contact your Honda dealer for a replacement.

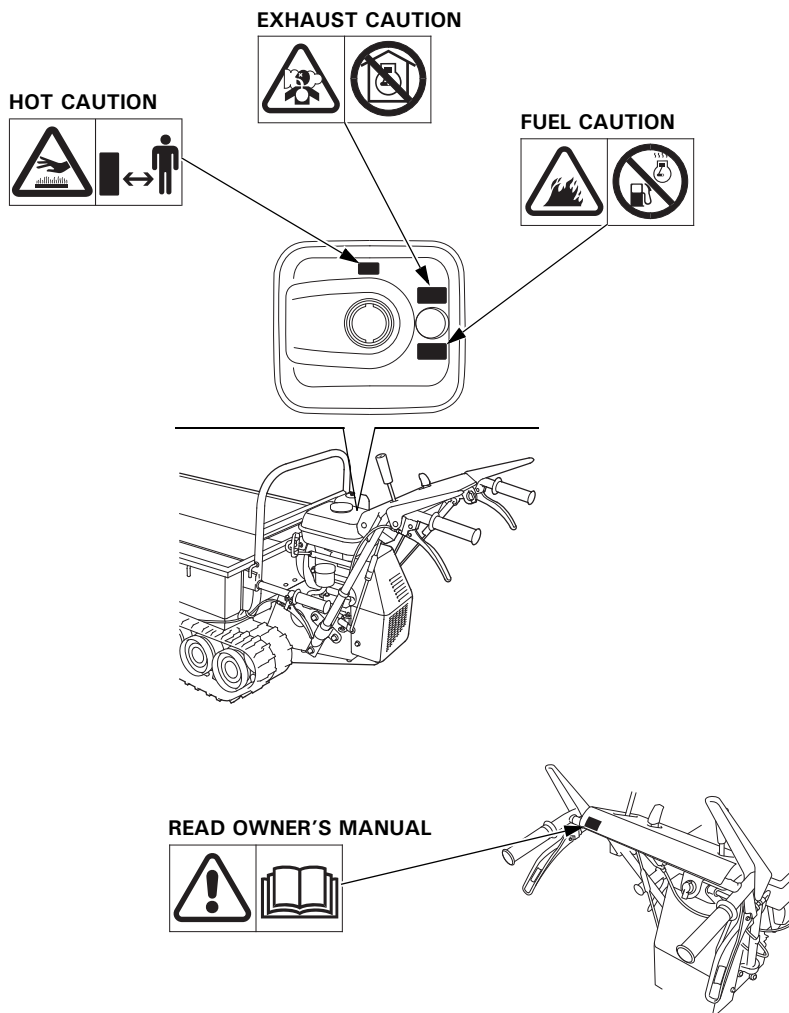





### 3. COMPONENT IDENTIFICATION

#### BXE1 type

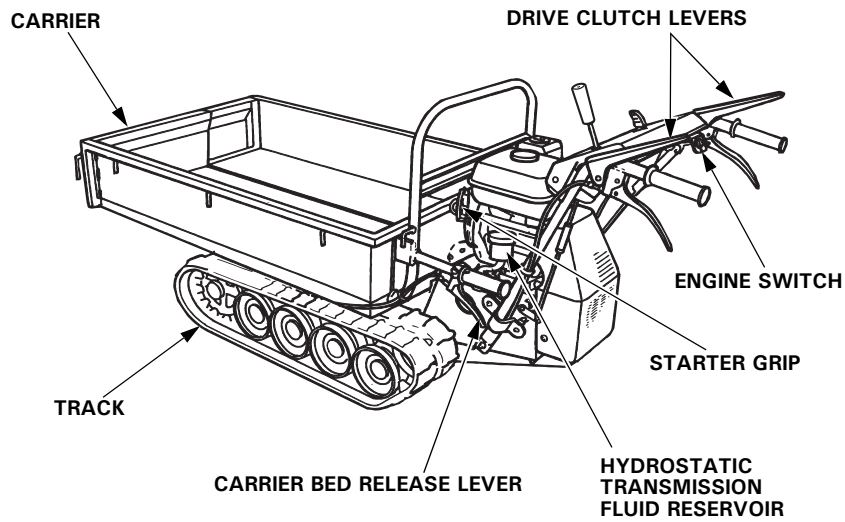

#### BXE1 type

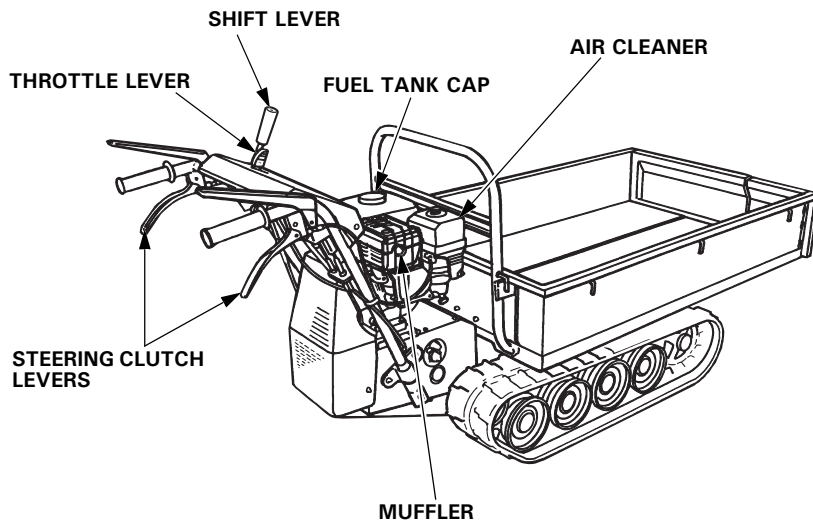

## 4. CONTROLS

### Fuel valve

The fuel valve opens and closes the fuel passage to the carburetor. Turn the fuel valve to the ON position before starting the engine and to the OFF position when the engine is stopped.

#### ▲WARNING

When the power carrier is not in use, always leave the fuel valve in the OFF position to reduce the possibility of fuel leakage. Gasoline is extremely flammable and is explosive under certain conditions. Fuel vapor or spilled fuel may ignite.

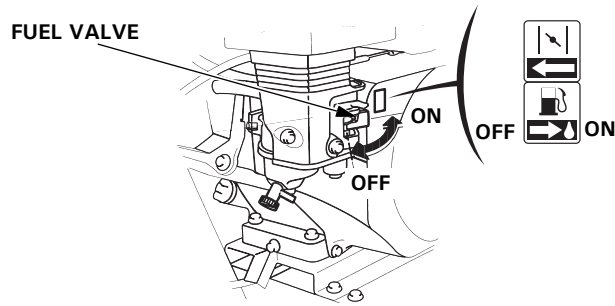

### Engine switch

The engine switch controls the electrical circuit for the spark plug ignition system and must be turned to the ON position to enable the engine to start and run. The engine will stop when the engine switch is turned to the OFF position.

#### ▲WARNING

When the power carrier is not in use always leave the engine switch in the OFF position to prevent accidental starting.

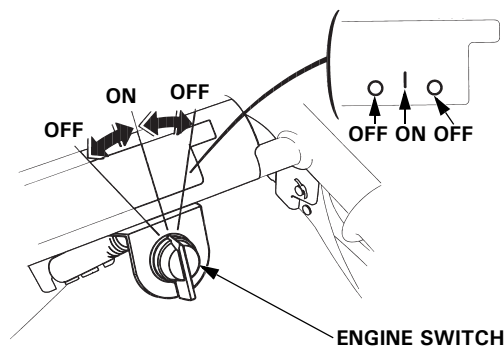

### Throttle lever

The throttle lever controls engine speed from SLOW to FAST, it will stay in any designated position.

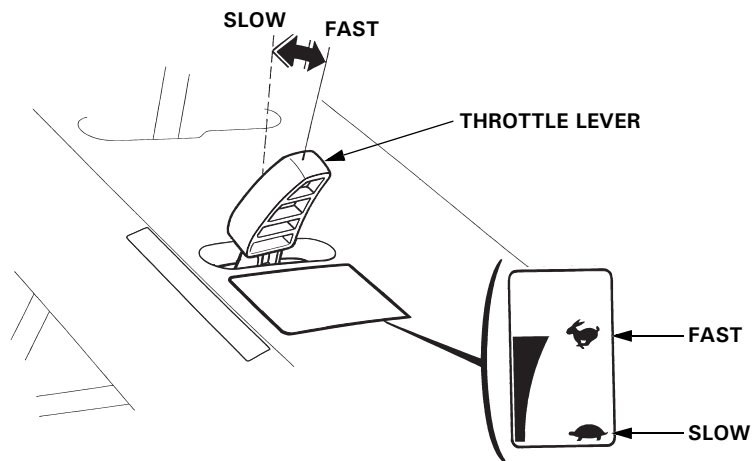

### Choke lever

The choke is used to provide proper starting mixture when the engine is cold.

It can be opened and closed by operating the valve lever manually. Move the lever to the CLOSED position to enrich the mixture.

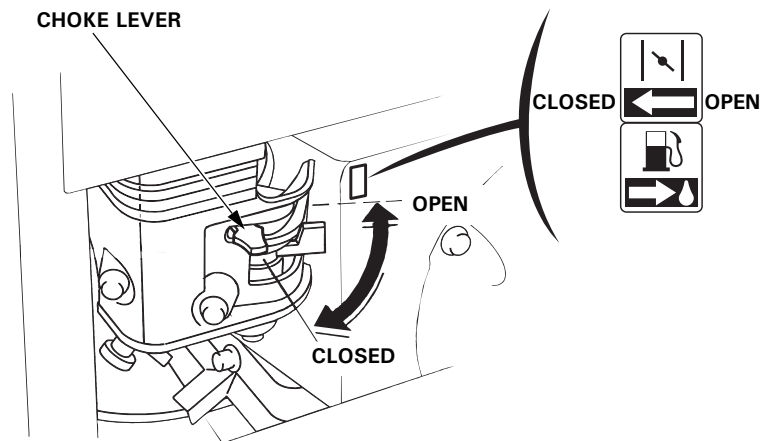

### Recoil starter

Pulling the starter grip operates the recoil starter to crank the engine for starting.

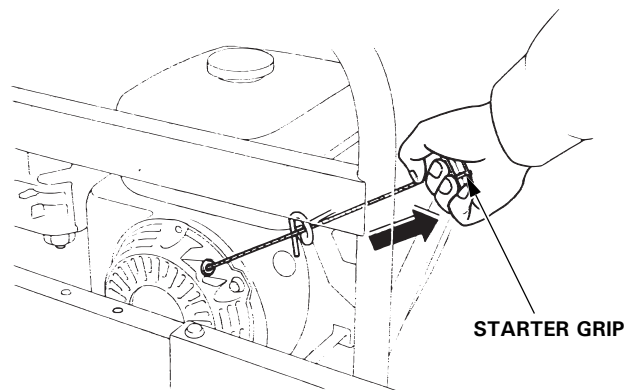

### Shift lever

Forward and reverse speeds can be selecting by shifting this lever; it will allow remain in any designated position. Set the lever in NEUTRAL position when power carrier is not used.

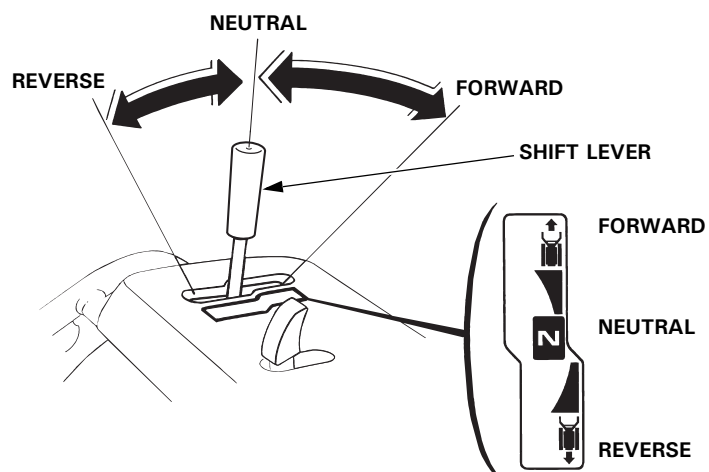

### Drive clutch levers

When this lever is squeezed, the power carrier travels; When it is released, the clutch cuts out, the brake is actuated and the power carrier stops.

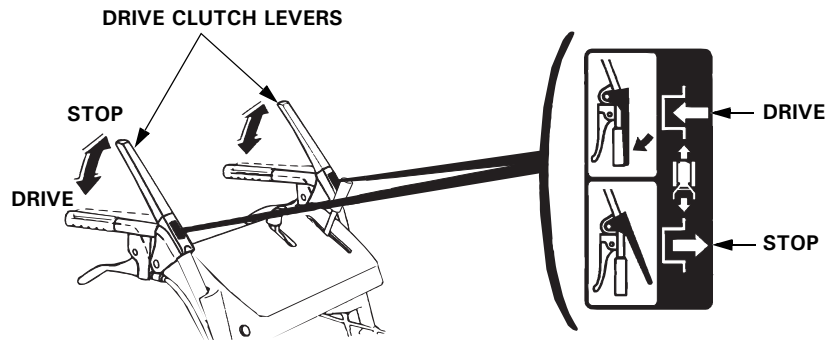

### Steering clutch levers

Use the steering clutch levers to steer the power carrier. Pull up the right lever to steer right. Pull up the left lever to steer left.

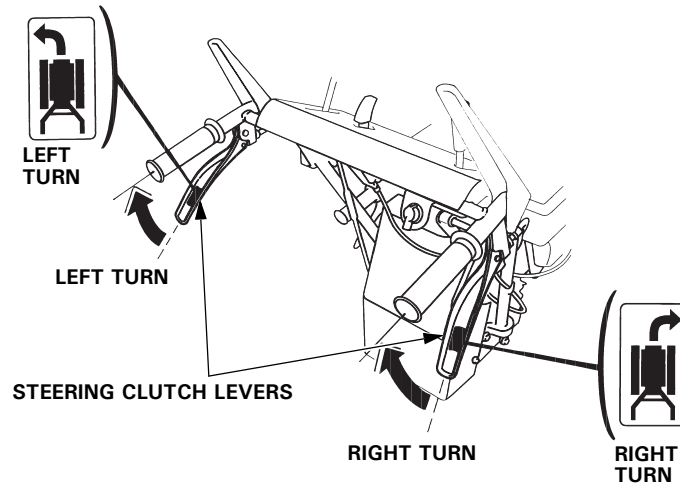

### Carrier bed release lever

Pull the release lever to unlock the carrier bed when you wish to tilt the bed for dumping a load. With the carrier bed unlocked, tilt it by lifting the handlebar. To lock the carrier bed again, push down firmly on the handlebar.

**▲WARNING**

**Before operating the power carrier check that the carrier bed is locked. If the carrier bed is not locked, it may tilt while going downhill and accidentally dump the load, which may cause personal injury and property or equipment damage.**

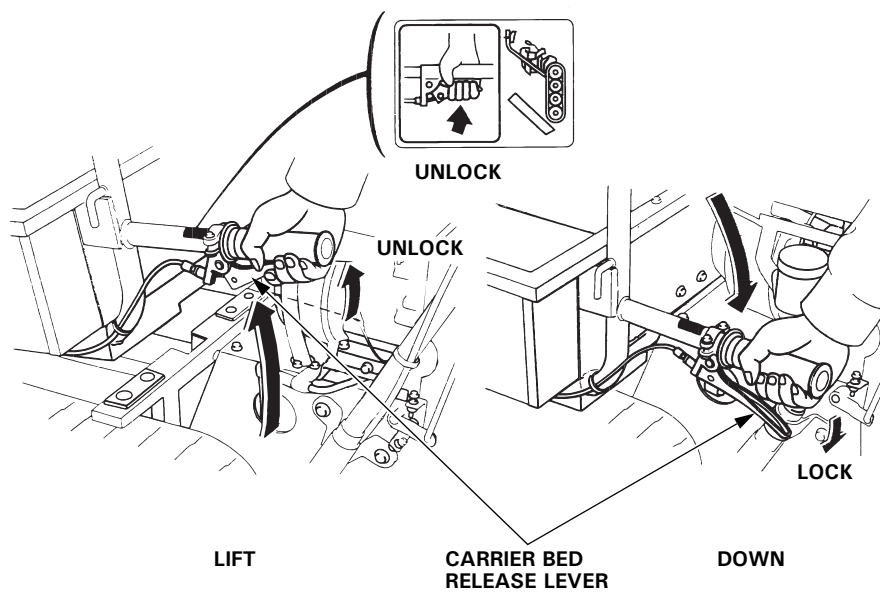

## 5. PRE-OPERATION CHECKS

### Checking the gasoline

Remove the filler cap and check the fuel level. Refill the tank if the fuel level is low. Do not fill above the shoulder of fuel strainer.

Use automotive unleaded gasoline with a Research Octane Number of 91 or higher (a Pump Octane Number of 86 or higher).

Never use stale or contaminated gasoline or an oil/gasoline mixture. Avoid getting dirt or water in the fuel tank.

#### ▲WARNING

- Gasoline is extremely flammable and is explosive under certain conditions.
- Refuel in a well-ventilated area with the engine stopped. Do not smoke or allow flames or sparks in the area where the engine is refueled or where gasoline is stored.
- Do not overfill the fuel tank (there should be no fuel in the filler neck). After refueling, make sure the filler cap is closed properly and securely.
- Be careful not to spill fuel when refueling. Spilled fuel or fuel vapor may ignite. If any fuel is spilled, make sure the area is dry before starting the engine.
- Avoid repeated or prolonged contact with skin or breathing of vapor.  
**KEEP OUT OF REACH OF CHILDREN.**

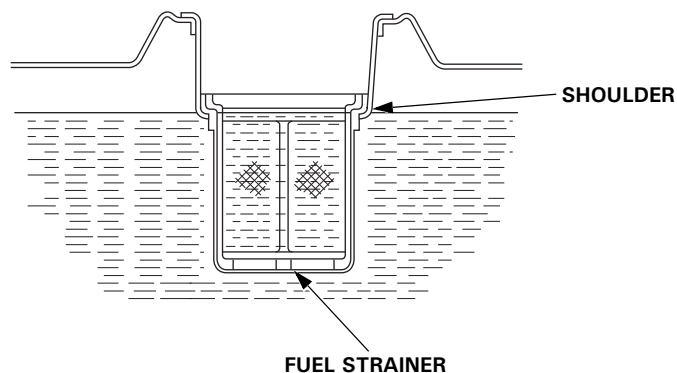



**NOTE:**

Gasoline spoils very quickly depending on factors such as light exposure, temperature and time.

In worst cases, gasoline can be contaminated within 30 days. Using contaminated gasoline can seriously damage the engine (carburetor clogged, valve stuck).

Such damage due to spoiled fuel is disallowed from coverage by the warranty.

To avoid this please strictly follow these recommendations:

- Only use specified gasoline (see page 13).
- Use fresh and clean gasoline.
- To slow deterioration, keep gasoline in a certified fuel container.
- If long storage (more than 30 days) is foreseen, drain fuel tank and carburetor (see page 49).

**Gasolines containing alcohol**

If you decide to use a gasoline containing alcohol (gasohol), be sure its octane rating is at least as high as that recommended by Honda.

There are two types of "gasohol": one containing ethanol, and the other containing methanol.

Do not use gasohol that contains more than 10% ethanol.

Do not use gasoline containing more than 5% methanol (methyl or wood alcohol) and that does not also contain co-solvents and corrosion inhibitors for methanol.

**NOTE:**

- Fuel system damage or engine performance problems resulting from the use of gasoline that contains more alcohol than recommended is not covered under the warranty.
- Before buying gasoline from an unfamiliar station, first determine if the gasoline contains alcohol, if it does, find out the type and percentage of alcohol used.

If you notice any undesirable operating symptoms while using a particular gasoline. Switch to a gasoline that you know contains less than the recommended amount of alcohol.

## Engine oil

The engine oil level must be checked with the power carrier parked on a level surface.

1. Remove the oil filler cap, and wipe the dipstick clean.
2. Check the oil level by inserting the dipstick into the filler neck without screwing it in.
3. If the level is low, fill to the top of the oil filler neck with the recommended oil.

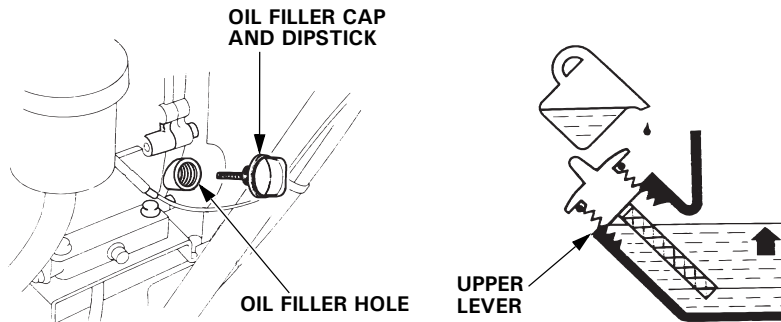

### Recommended oil

Use 4-stroke motor oil that meets or exceeds the requirements for API service classification SE or later (or equivalent). Always check the API service label on the oil container to be sure it includes the letters SE or later (or equivalent).

SAE 10W-30 is recommended for general use. Other viscosities shown in the chart may be used when the average temperature in your area is within the indicated range.

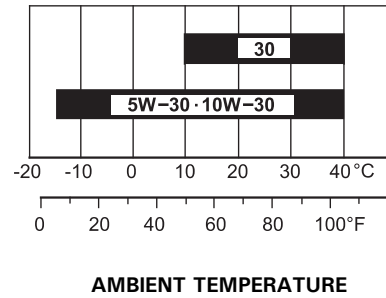

### CAUTION:

- Engine oil is a major factor affecting engine performance and service life. Non-detergent oil and 2-stroke engine oil are not recommended.
- Running the engine with insufficient oil can cause serious engine damage.

## Air cleaner

Check that the foam element is clean and in good condition. A dirty air cleaner will restrict air flow to the carburetor, reducing engine performance. A damaged air cleaner will allow dirt to enter the engine, causing rapid engine wear.

1. Unscrew the wing nut, remove the air cleaner cover.
2. Remove and inspect the foam element.  
If the element is dirty, follow the cleaning procedure described on page 39.
3. Reinstall the foam element, cover and wing nut. Securely tighten the wing nut.

### CAUTION:

**Never run the engine without the air cleaner. Rapid engine wear will result from contaminants, such as dust and dirt, being drawn through the carburetor, into the engine.**

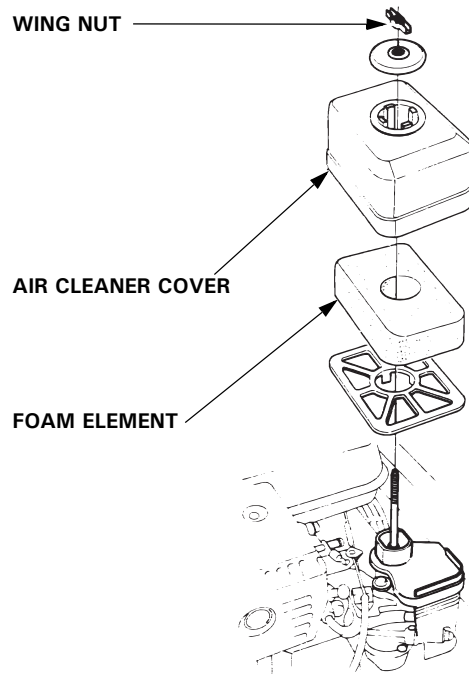

## Hydrostatic transmission (HST) fluid

Check the transmission fluid level when the transmission is cold and with the power carrier parked on level ground.

Make sure the fluid level is between the upper and lower marks on the reservoir. If the level has dropped close to or below the lower mark, add the recommended transmission fluid until it reaches the upper mark as follows.

### Recommended fluid

Use 4-stroke motor oil that meets or exceeds the requirements for API service classification SE or later (or equivalent). Always check the API service label on the oil container to be sure it includes the letters SE or later (or equivalent).

1. Unscrew the reservoir cap and remove the seal. Be careful to prevent dirt and water from entering the reservoir.
2. Add recommended fluid to bring the fluid level to the UPPER level mark. Do not overfill.
3. Reinstall the seal, and tighten the cap securely.

### CAUTION:

Operating the power carrier with low transmission fluid level will cause serious transmission damage. Stop the power carrier immediately and have it checked by your Honda power carrier dealer.

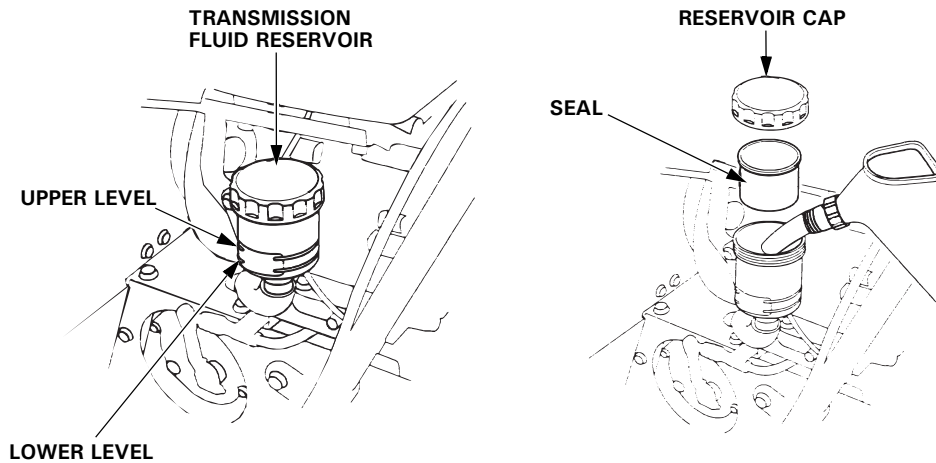

## Tracks

Inspect the tracks for signs of damage and excessive slack.  
When a force <about 98 N (10 kgf, 22 lbf)> is applied to the middle of the tracks, check that the slackness is between:

8.0–12.0 mm (0.31–0.47 in)

For adjustment, refer to page 47.

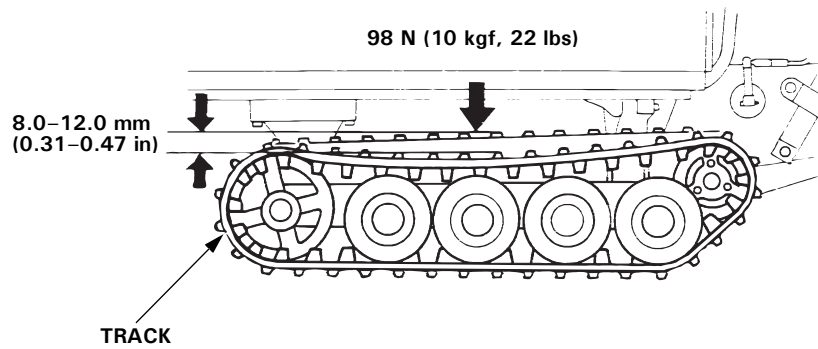

## 6. STARTING THE ENGINE

(Once you have familiarized yourself with the procedure for stopping the engine, before start the engine).

1. Move the shift lever to the NEUTRAL position, and the drive clutch lever to the STOP position.

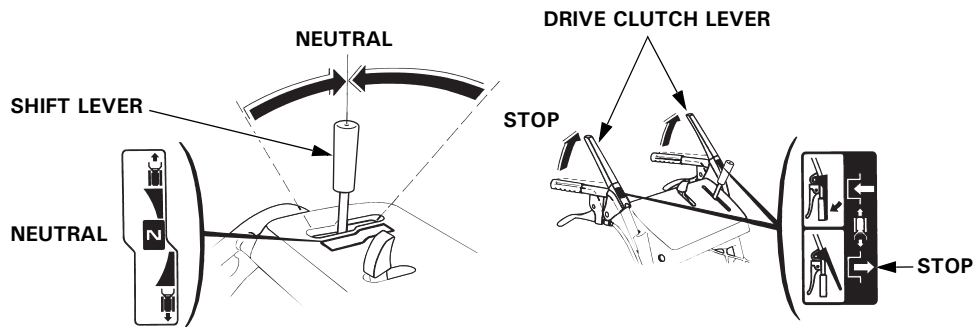

2. Turn the fuel valve to the ON position.  
Be sure that the drain knob is tightened securely.

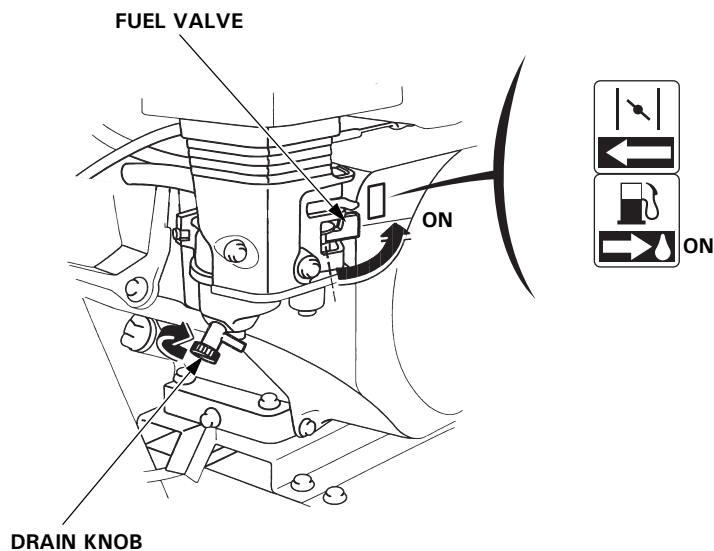

3. In cold weather and when the engine is cold, turn the choke lever to the CLOSED position.

**NOTE:**

Do not use the choke if the engine is warm or the air temperature is high.

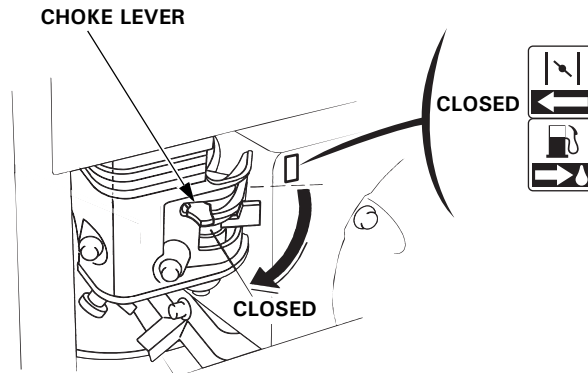

4. Turn the engine switch to the ON position.

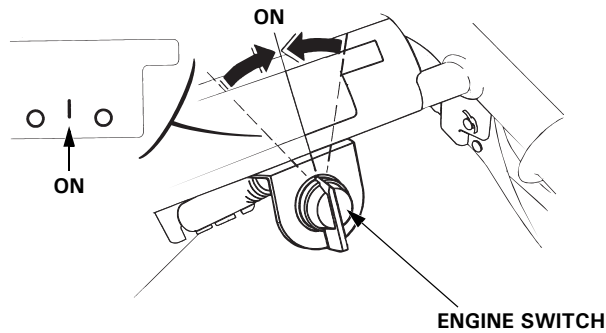

5. Set the throttle lever midway between the SLOW and FAST positions.

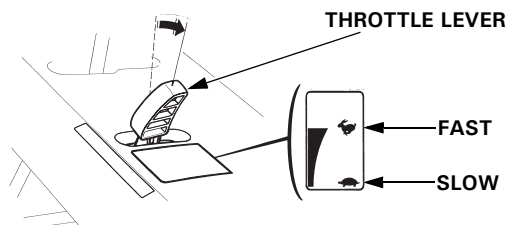

6. Pull the starter grip lightly until you feel resistance, then pull briskly in the direction of the arrow as shown below.

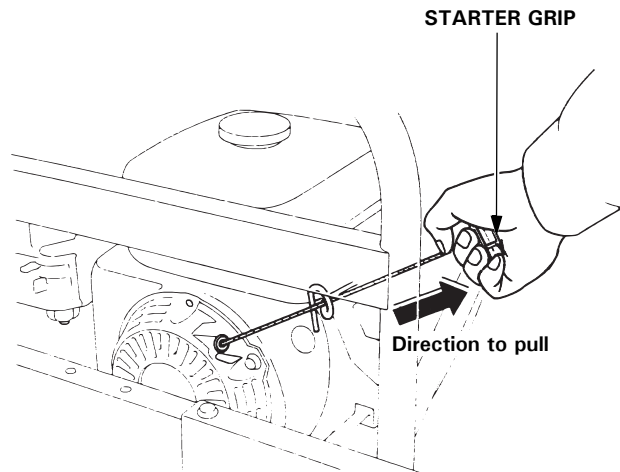

**CAUTION:**

- Do not allow the starter grip to snap back against the engine. Return it gently to prevent damage to the starter.
- Do not pull the starter grip while the engine is running, as that may damage the starter.

7. If the choke lever has been moved to the CLOSED position to start the engine, gradually move it to the OPEN position as the engine warms up.

Move the throttle lever to the SLOW position when the engine is warm enough to idle smoothly.



## High altitude operation

At high altitude, the standard carburetor air-fuel mixture will be excessively rich. Performance will decrease, and fuel consumption will increase.

High altitude performance can be improved by specifications to the carburetor. If you always operate the power carrier at altitude higher than 1,500 m (5,000 ft) above sea level, have your authorized Honda dealer perform these carburetor modifications.

Even with suitable carburetor jetting, engine horsepower will decrease approximately 3.5% for each 300 m (1,000 ft) increase in altitude. The effect of altitude on horsepower will be greater than this if no carburetor modification is made.

### **CAUTION:**

**Operation of the power carrier at an altitude lower than the carburetor is jetted for may result in reduced performance, overheating, and serious engine damage caused by an excessively lean air-fuel mixture.**

## 7. OPERATION

**CAUTION:**

**Before starting work, check the operation of the brakes.**

1. Start the engine as instructed on page 19.
2. Move the throttle lever to the FAST position.

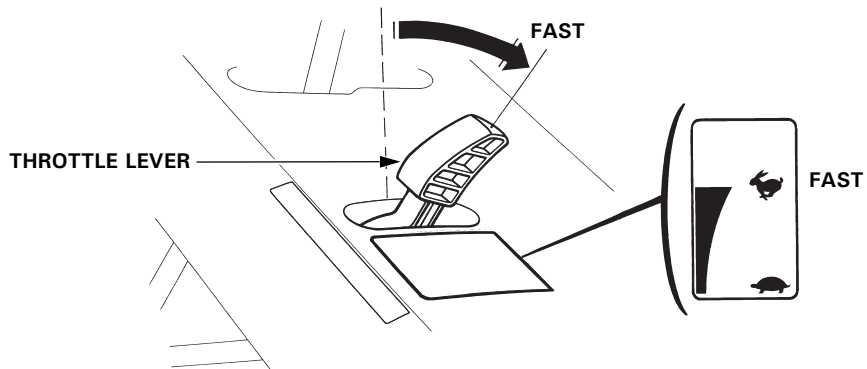

3. Release the drive clutch levers and move the shift lever to select the desired drive speed.  
You can change the drive speed while the power carrier is running.

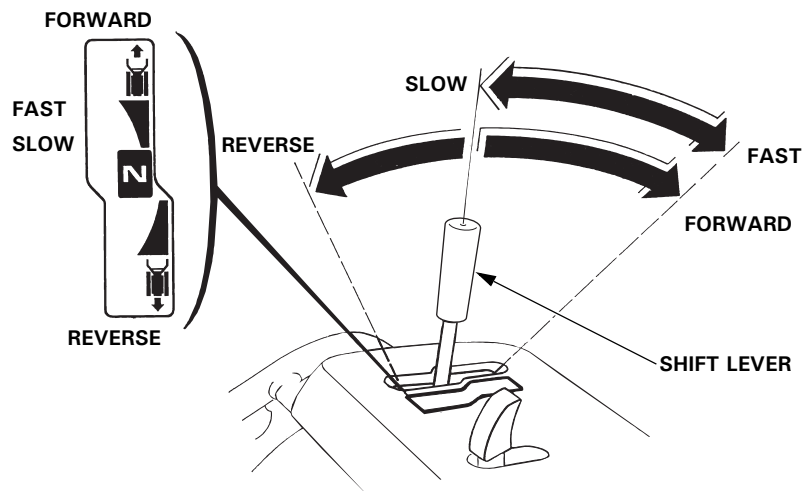

4. Squeeze the drive clutch levers to start the power carrier.

**NOTE:**

The power carrier starts when either right or left drive clutch is squeezed. The power carrier stops when the drive clutch is released.

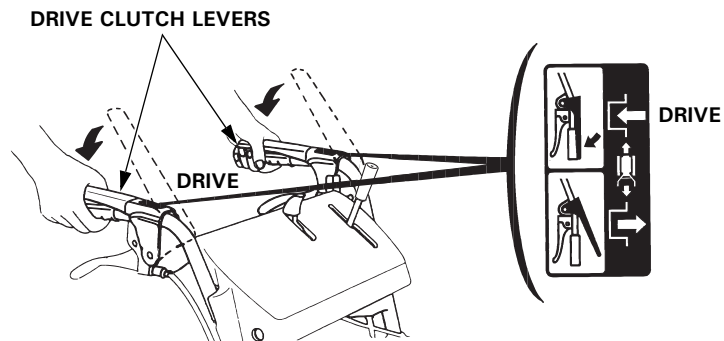

**▲WARNING**

- When operating on hills, reduce speed and exercise extreme caution.
- If the engine stalls on a slope, release the drive clutch levers immediately to stop the power carrier and avoid loss of control.

5. Use the steering clutch levers to steer the power carrier. Pull up the right lever to steer right. Pull up the left lever to steer left.

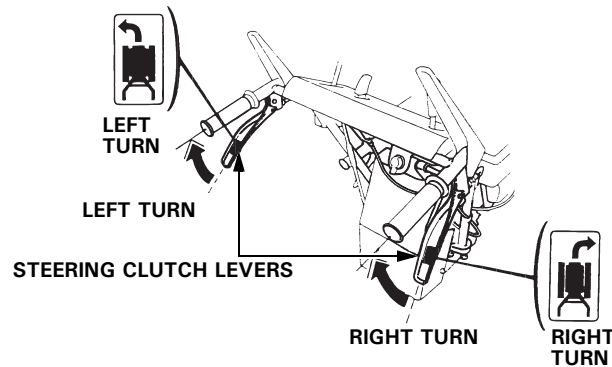

**▲WARNING**

The turning action is abrupt. Be sure that loads are properly secured. Exercise special care when steering on a slope.

## 8. CARRYING LOADS

### Load carrying safety

#### **▲WARNING**

To avoid accidents or overturning:

- Observe the load limits described on page 29.
- Do not stack the load so that the power carrier becomes top-heavy and unstable.
- Carry only lightweight loads when the carrier side rails are extended.
- Do not allow the load to protrude from the power carrier or block visibility.
- Secure the load to the tie-down hooks with strong ropes or straps.
- Before operating the power carrier, check that the carrier bed is locked.
- When operating the power carrier on ground that is soft or uneven, reduce speed and exercise extra care.
- When operating the power carrier on hills, reduce speed and exercise extreme caution.  
Never descend slopes in reverse gear.
- Exercise extra care when starting, stopping, or changing the direction of the power carrier while operating it on slopes.
- Do not carry loads on upward slopes greater than 25° (46%) or downward slopes greater than 15° (26%).
- When carrying a heavy load, give special consideration to the balance of the unit, making sure the load is even and not leaning. If the load is leaning, the unit may overturn during take-off, while stopping, or when travelling on a bad road, resulting in serious injury.

## Tie-down hooks

### CAUTION:

When loading objects onto the carrier, be sure to adhere to the regulated loading weight, proper loading methods and tilt angle. Failure to heed these regulations will not only exert an adverse effect on the engine and frame but will also pose extreme danger from the load collapsing or toppling over.

Secure the load in the carrier bed with strong ropes or straps attached to the tie-down hooks.

### CAUTION:

Do not attach ropes or straps to locations other than the tie-down hooks.

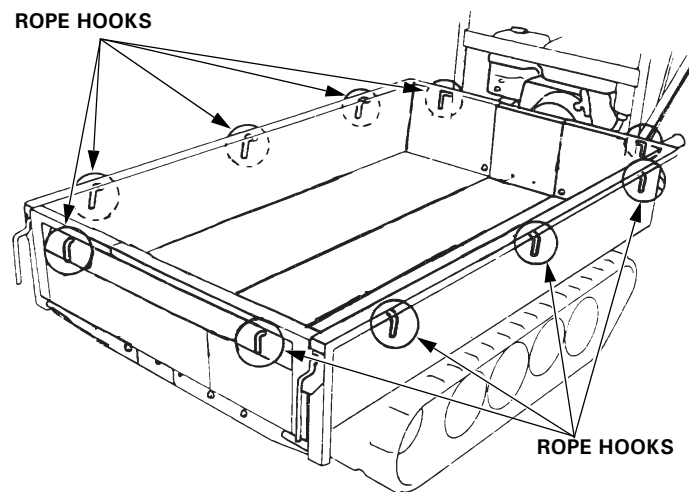

## Side plates

The side plates may be extended up to 85 mm, 170 mm (3.3 in, 6.7 in) at each side for carrying bulky, lightweight loads.

To extend the side plates loosen the ten lock bolts, pull both side plates out an equal amount, then tighten the lock bolts securely.

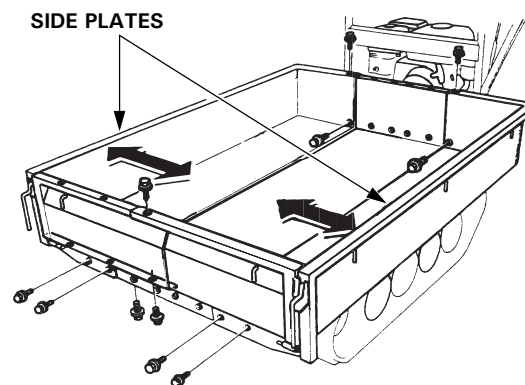

### CAUTION:

- Extend the side plates for use with lightweight loads only. A heavy load, extended on the sides of the power carrier will increase the hazard of overturning.
- Extend left and right side plates an equal amount, and center the load. Do not extend the side plates more than is necessary to hold the load and never more than 170 mm (6.7 in) at each side.

## Dumping loads

Dump loads with the power carrier stopped and the drive clutch levers released.

1. Pull the carrier bed release lever, and tilt the carrier bed by lifting the handlebar.
2. After dumping the load, push down firmly on the handlebar to lock the carrier bed in the normal position.

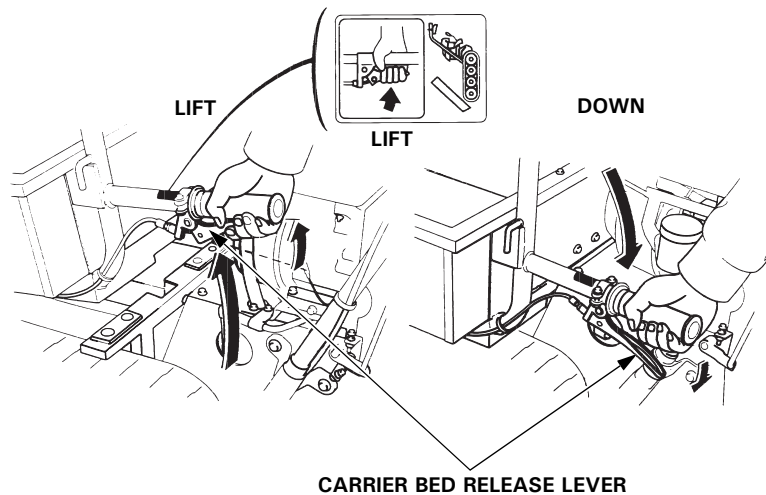

### **▲WARNING**

Before operating the power carrier check that the carrier bed is locked. If the carrier bed is not locked, it may tilt while going downhill and accidentally dump the load, which may cause personal injury and property or equipment damage.

## Load carrying capacity

### ▲WARNING

To avoid personal injury and property or equipment damage due to overturning, do not carry loads on upward slopes greater than 25° (46%) or downward slopes greater than 15° (26%). Observe the following safe loading and operating limits:

- For operation on level ground–  
Maximum load: 500 kg (1,102 lbs)  
Maximum load height: 900 mm (35.4 in)

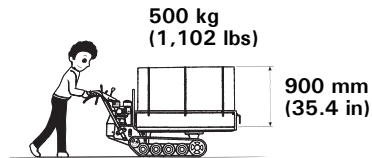

- For operation on slopes–  
Maximum load: 350 kg (772 lbs)  
Maximum slope: 25° (46%) upward/15° (26%) downward

Slope with gradient  
of under 25° (46%)

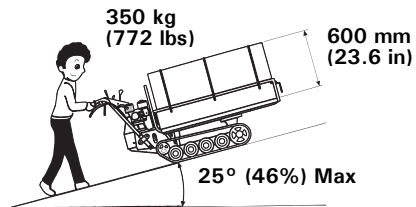

Slope with gradient  
of under 15° (26%)

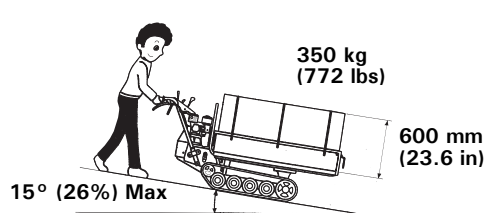



---

### Using the power carrier on slopes

#### Driving:

1. Be sure to reduce speed and exercise extreme caution.
2. If the ground is unstable, reduce the speed and tread carefully when proceeding with the work at hand.
3. Special care is needed for advancing and stopping the power carrier on slopes.
4. Avoid changing speed and making U-turns on steep slopes.

#### Loading:

1. A load will be less stable on a slope and so it should be secured with rope.
2. The power carrier may be less stable depending on the condition of the road surface. In such cases, keep the load to the minimum.
3. Visibility in the forward direction is impaired on slopes and so keep the height of the load to minimum.

## 9. STOPPING THE ENGINE

- In an emergency

1. Release the drive clutch levers to stop the power carrier.

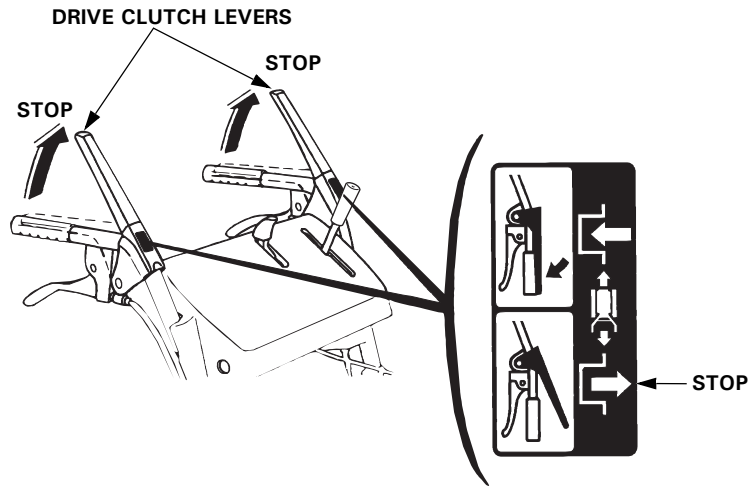

2. Turn the engine switch OFF.

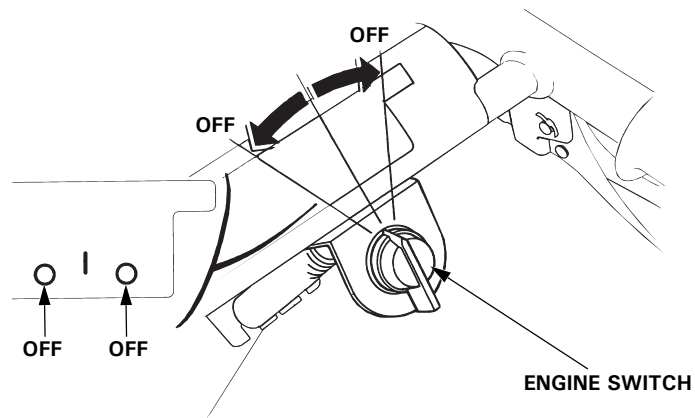

To restart the engine, move the shift lever back to the LOW position.

• In normal use

1. Move the shift lever to the NEUTRAL position.

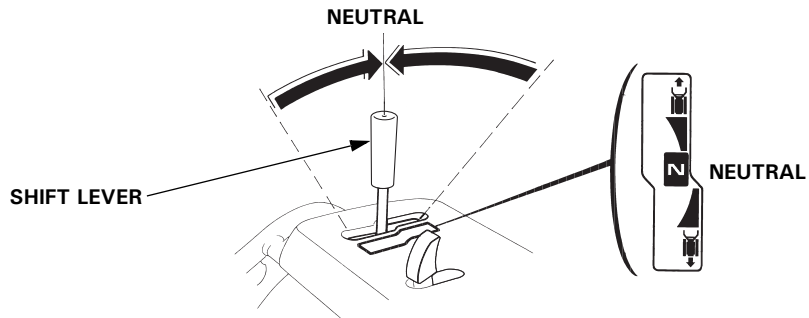

2. Release the drive clutch levers to stop the power carrier.

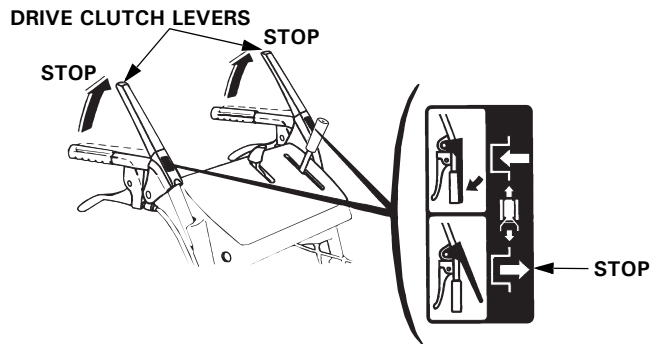

3. Move the throttle lever to the SLOW position.

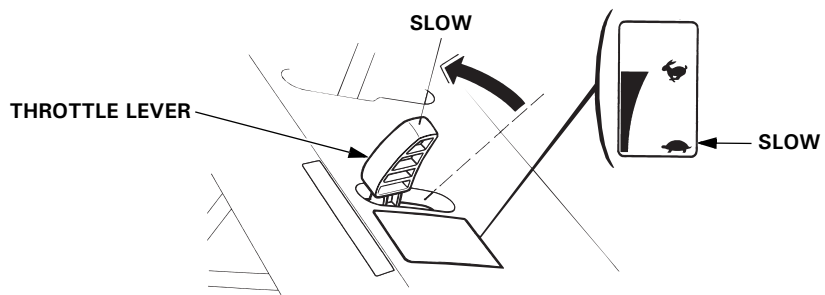

4. Turn the engine switch to the OFF position.

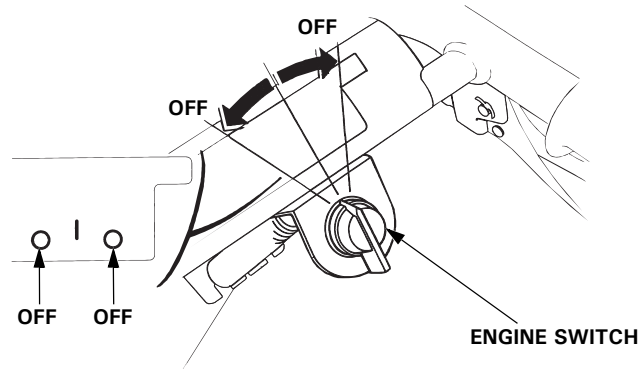

5. Turn the fuel valve to the OFF position.

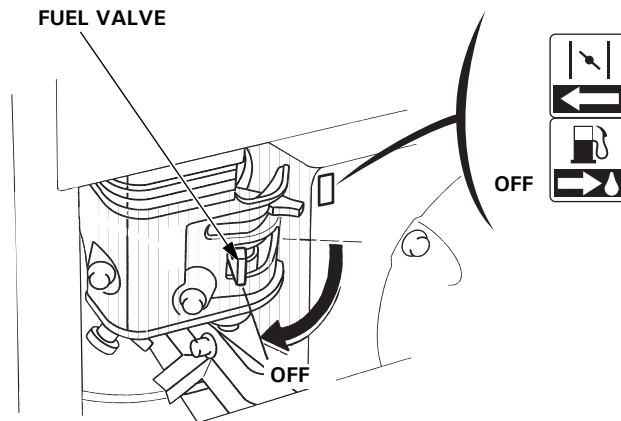

### Transporting

Transport the power carrier on a flat, level trailer or in a pickup truck with the fuel valve in the OFF position and the drive clutch lever in the STOP position. Use the tie-down ropes to secure the power carrier to the floor.

## 10. MAINTENANCE

---

Periodic maintenance and adjustment is necessary to keep the power carrier in good operating condition. Service and inspect according to the maintenance schedule.

**▲WARNING**

**Shut off the engine before performing any maintenance. If the engine must be run, make sure the area is well-ventilated. Exhaust contains poisonous carbon monoxide gas that may cause loss of consciousness and lead to death.**

**CAUTION:**

**Use genuine Honda parts or their equivalent. The use of replacement parts which are not of equivalent quality may damage the engine.**

## Maintenance schedule

Your power carrier should be serviced regularly to assure maximum service life.

REGULAR SERVICE PERIOD (3) Perform at every indicated month or operating hour interval, whichever comes first.		Each use	First month or 20 hrs	Every 3 months or 50 hrs	Every 6 months or 100 hrs	Every year or 200 hrs
ITEM						
Engine oil	Check level	o				
	Change		o		o	
Air cleaner	Check	o				
	Clean			o (1)		
Tracks	Check	o				
	Adjust		o			o
HST fluid	Check	o				
Drive clutch cable	Check-adjust		o		o	
Side clutch cable	Check-adjust		o		o	
Brake cable	Check-adjust		o		o	
Spark plug	Check-adjust				o	
	Replace					o
Carrier lock cable	Check-adjust				o	
Throttle cable	Check-adjust					o (2)
Brake shoe	Check				o	
	Change					o (2)
Clutch shoe	Change					o (2)
Transmission oil	Check					o
Grease application	Check					o
Idle speed	Check-adjust					o (2)
Valve clearance	Check-adjust					o (2)
Combustion chamber	Clean	After every 250 hrs (2)				
Fuel tank and filter	Clean					o (2)
Fuel tube	Check	Every 2 years (Replace if necessary) (2)				

- NOTE: (1) Service more frequently when used in dusty areas.  
 (2) These items should be serviced by your servicing dealer, unless you have the proper tools and are mechanically proficient. Refer to Honda shop manual for service procedures.  
 (3) For commercial use, log hours of operation to determine proper maintenance intervals.

## Tools

The tools supplied with the carrier are necessary for performing some periodic maintenance, simple adjustments and repairs. Always keep the tool kit with the carrier.



SPARK PLUG WRENCH HANDLE



SPARK PLUG WRENCH

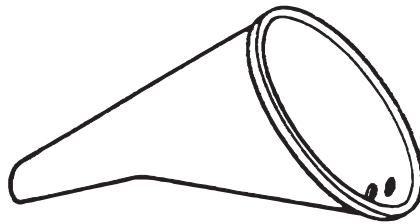

OIL FUNNEL

## Engine oil change

### NOTE:

Drain the oil while the engine is still warm to assure rapid and complete draining.

### Changing the oil

1. Remove the engine oil filler cap and loosen the oil drain bolt.
2. Set the oil funnel as shown, remove the oil drain bolt and drain the oil into a suitable container.
3. Once the oil has been drained, tighten the oil drain bolt securely.
4. Fill with new recommended engine oil (see page 15) to the top of the oil filler neck.
5. After replenishment, tighten the cap securely.

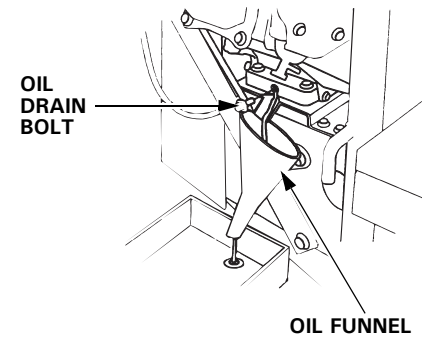

### Oil capacity:

0.58 L (0.61 US qt, 0.51 Imp qt)

Wash your hands with soap and water after handling used oil.

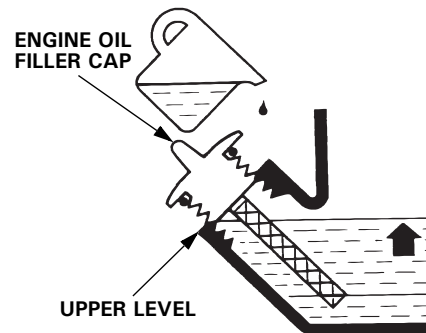

### NOTE:

Please dispose of used motor oil in a manner that is compatible with the environment. We suggest you take it in a sealed container to your local service station for reclamation. Do not throw it in the trash or pour it on the ground.



## Spark plug service

**Recommended spark plug:** BPR6ES (NGK)  
W20EPR-U (DENSO)

### ▲WARNING

**If the engine has been running, the muffler will be very hot. Be careful not to touch the muffler.**

To ensure proper engine operation, the spark plug must be properly gapped and free of deposits.

1. Clean any dirt from around the spark plug base.
2. Disconnect the spark plug cap and then remove the spark plug with the spark plug wrench.
3. Visually inspect the spark plug. Discard it if there is apparent wear or if the insulator is cracked or chipped. Clean the spark plug with a wire brush if it is to be reused.
4. Measure the plug gap with a feeler gauge.

Correct as necessary by carefully bending the side electrode.

The gap should be:

0.7–0.8 mm (0.028–0.031 in)

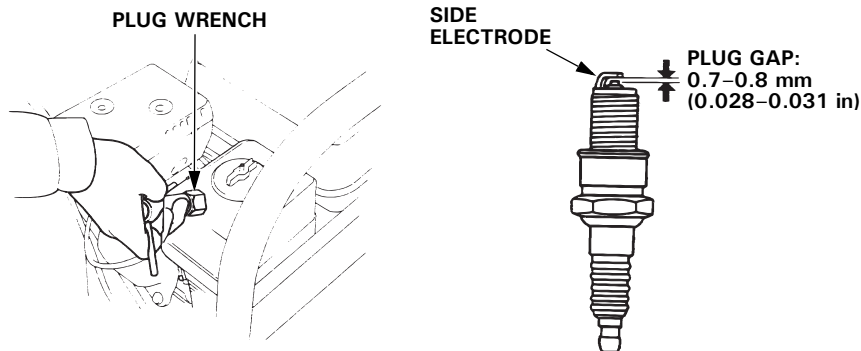

### CAUTION:

- The spark plug must be securely tightened. An improperly tightened spark plug can become very hot and may damage the engine.
- Use only the recommended spark plug or equivalent. Spark plugs which have an improper heat range may cause engine damage.

## Servicing the air cleaner

A dirty air cleaner will restrict air flow to the carburetor. To prevent carburetor malfunction, service the air cleaner regularly. Service more frequently when operating the power carrier in extremely dusty areas.

### ▲WARNING

**Never use gasoline or low flash point solvents for cleaning the air cleaner element. A fire or explosion could result.**

### CAUTION:

**Never run the engine without the air cleaner. Rapid engine wear will result from contaminants, such as dust and dirt, being drawn through the carburetor, into the engine.**

1. Unscrew the wing nut, remove the air cleaner cover and remove the foam element.
2. Wash the element in a solution of household detergent and warm water, then rinse thoroughly, or wash in nonflammable or high flash point solvent. Allow the element to dry thoroughly.
3. Soak the element in clean engine oil and squeeze out the excess oil. The engine will smoke during initial start-up if too much oil is left in the element.
4. Reinstall the foam element and the cover.

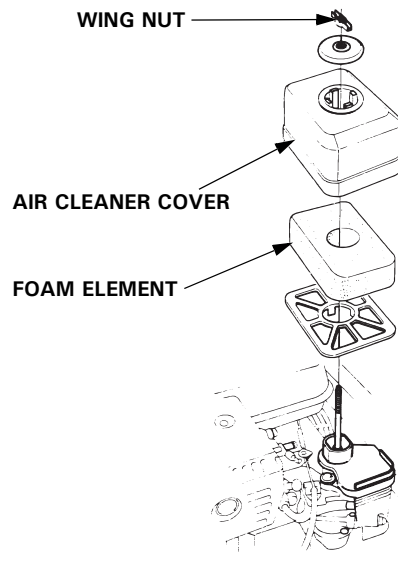

## Adjusting the track tautness

If the tracks are not properly taut, they may slip off the wheels or their service life may be markedly reduced.

### Inspection

When a force <about 98 N (10 kgf, 22 lbf)> is applied to the middle of the tracks, check that the slackness is between:

8.0–12.0 mm (0.31–0.47 in)

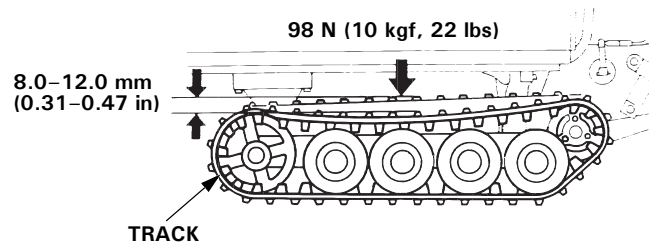

### Track adjustment

1. Tip up the carrier.  
Loosen the two lock nuts until there is space between the nuts and the frame.
2. Tighten the inner lock nut by hand until clearance between the lock nut and frame is:  
5.0–10.0 mm (0.20–0.39 in)
3. Hold the inner lock nut and tighten the other lock nut against it securely.

#### NOTE:

Use the two 19 mm wrenches furnished with the power carrier as illustrated.

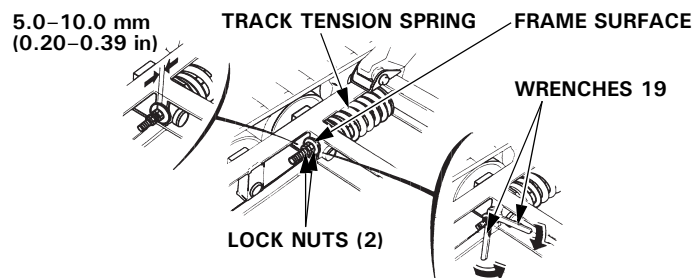

## Adjusting the drive clutch cable

The clutch will slip and the power carrier may not move unless the drive clutch cable is adjusted properly.

### Inspection

1. Remove the belt cover.
2. Move the drive clutch lever to the STOP position.
3. Measure the length "ℓ" of the belt tension spring with the drive clutch lever in the STOP position.
4. Move the drive clutch lever to the DRIVE position, and again measure the length "ℓ" of the belt tension spring.
5. The difference between the two measurements should be between:  
5.0–7.0 mm (0.20–0.28 in)

### Adjustment

If the difference is below 5 mm (0.20 in), adjust the cable as follows:

1. Move the drive clutch lever to the STOP position and loosen the cable lock nut.
2. Turn the adjusting nut until the difference is 7 mm (0.28 in).
3. After the adjustment, tighten the lock nut securely.

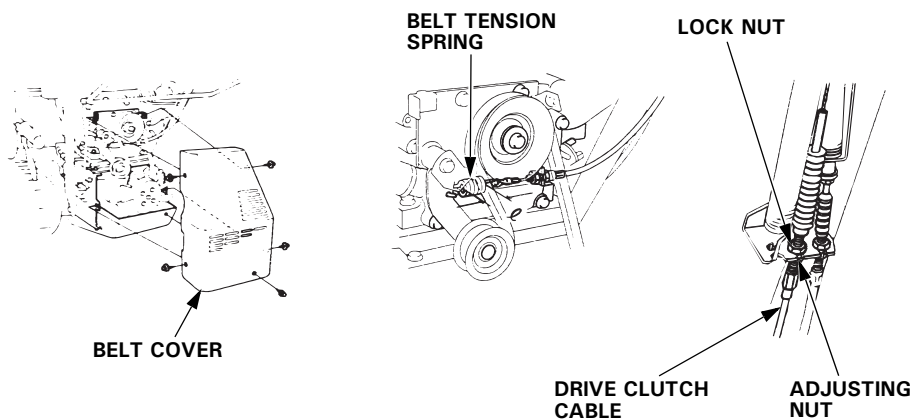

## Adjusting the brake cable

Braking effectiveness will be impaired if the brake cable is not adjusted properly.

### Adjustment

1. With the drive clutch lever set in the STOP position (brake is applied), measure the brake spring collar to spring holder distance:  
Specified distance: 14.0–16.0 mm (0.55–0.63 in)
2. If adjustment is necessary, loosen the lock nuts and move the brake cable until the correct distance is obtained.
3. After the adjustment, tighten the lock nuts securely.

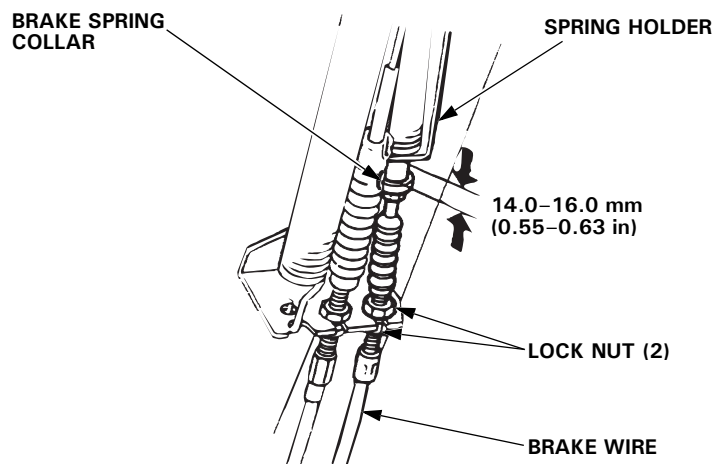
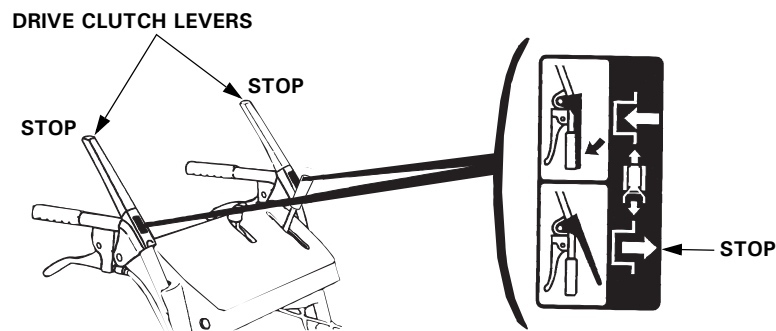

---

### Checking brake wear

Inspect the brake shoes to determine the shoe wear whenever the brake cable is adjusted.

If the side of the brake arm lines up with the wear limit hole when the drive clutch lever is moved to the STOP position, have the brake shoes replaced by your Honda power carrier dealer.

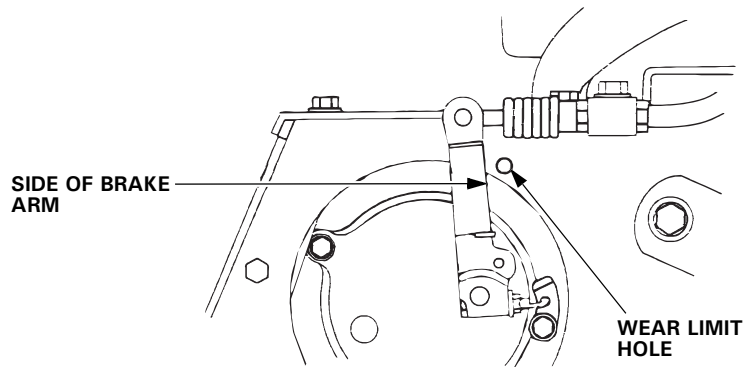

## Adjusting the side clutch cable

Steering control will be impaired unless both side clutch cables are adjusted properly.

1. With the engine off, rock the power carrier forward and backward to find the position at which each lever can be pulled closest to the handle grip.
2. With each steering clutch lever fully gripped, check whether the clearance between the projection on the lever and the handle grip is:  
30.0–35.0 mm (1.18–1.38 in)
3. To adjust, loosen the lock nut with the lever gripped and turn the adjust nut to get the prescribed clearance.
4. After the adjustment, tighten the lock nut.

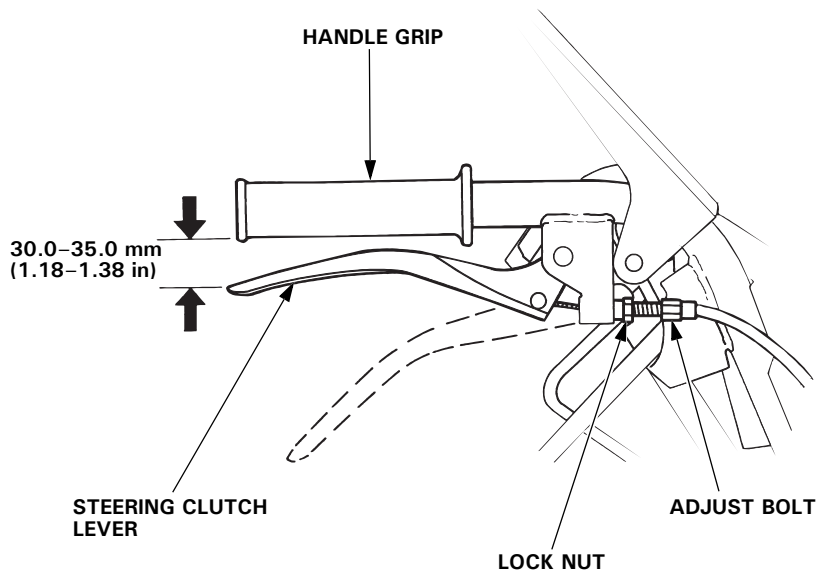

### Adjusting the dumping lock cable

1. With the carrier locked, check whether the play at the end of the dumping lock release lever is: 15.0–20.0 mm (0.59–0.79 in)
2. To adjust, loosen the lock nut and turn the adjust bolt to set the prescribed distance.
3. After the adjustment, tighten up the lock nut.

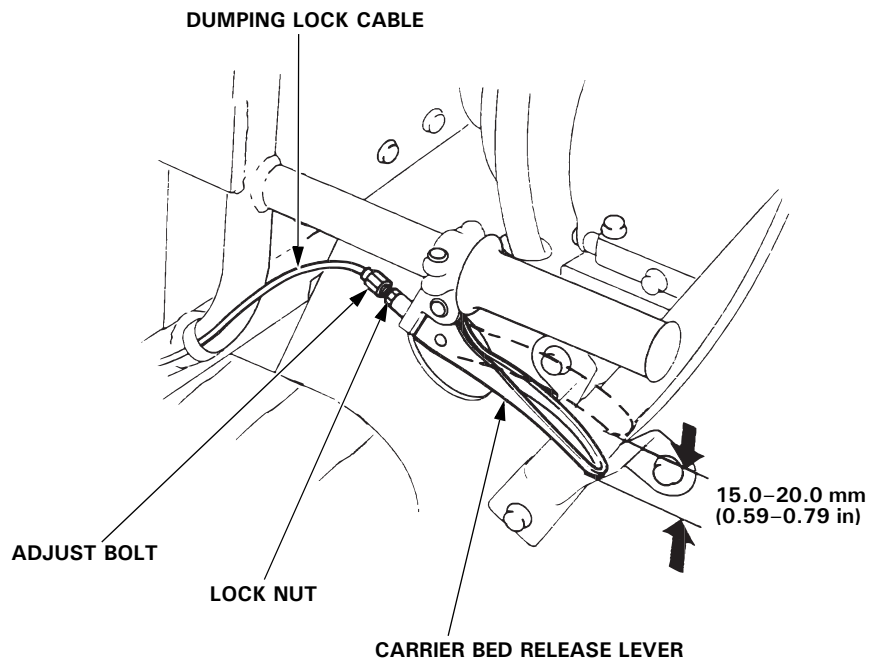



## Checking the transmission oil

Remove the oil cap and check that the oil is up to the lower edge of the check bolt hole. If it is low, consult your Honda dealer.

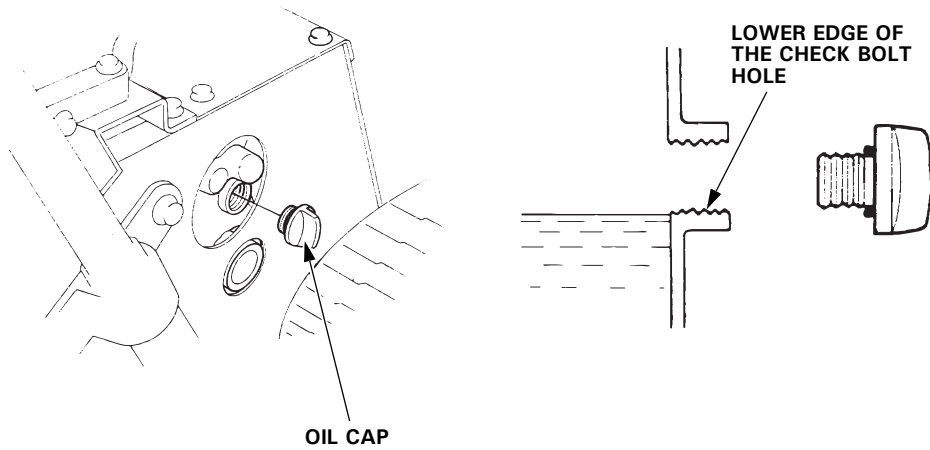

## Lubrication

Grease the points noted below, at least once a year or after any time you have washed the carrier.

Recommended grease: SAE multipurpose grease.

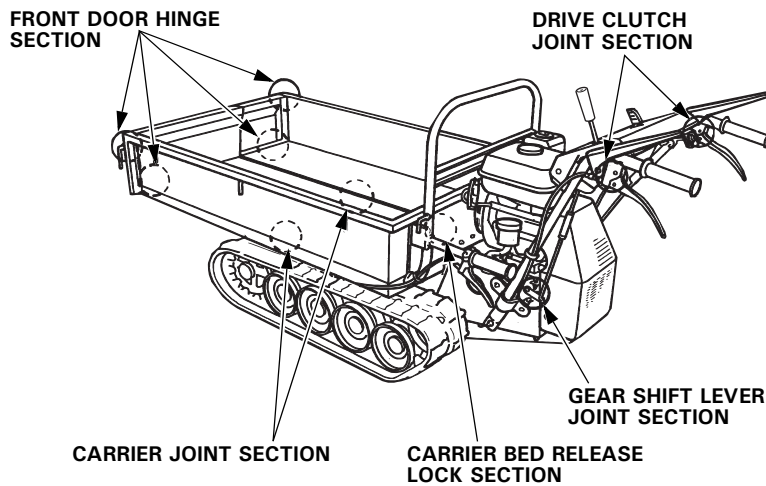

### Temporary installation of a disengaged track

In the unlikely event that a track slips off the sprockets during operation, proceed with the following:

1. Stop the engine (refer to page 31).
2. Remove any load in the carrier, by hand. Do not empty it by dumping the carrier.
3. Move the power carrier to a flat surface and support on wooden blocks in two locations (so the wheels are off the ground). Dump the carrier.

**CAUTION:**

**A carrier with a disengaged track will fall over if the carrier is dumped, unless first secured with wooden blocks.**

4. Loosen the track tension lock nuts and tighten up the inner nut as far as it will go. (This is done in order to facilitate the mounting of the track.)
5. Remove the sprocket bolts.

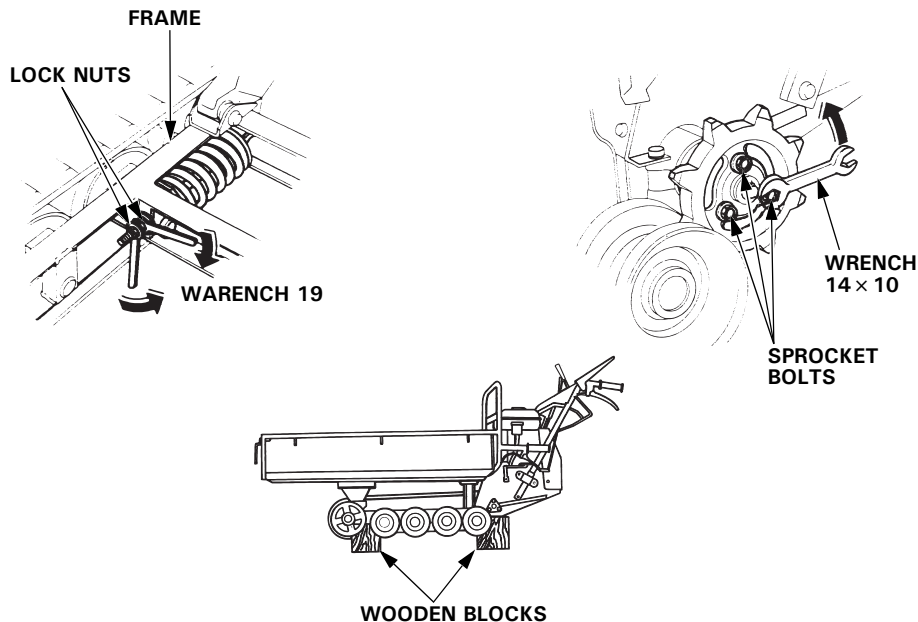

6. Remove the sprocket.
7. Place the track over the driven wheel, and engage the sprocket with the track teeth.
8. Push the sprocket and track toward the rear, then slide the sprocket onto the sprocket shaft.
9. Install and tighten the sprocket bolts securely.

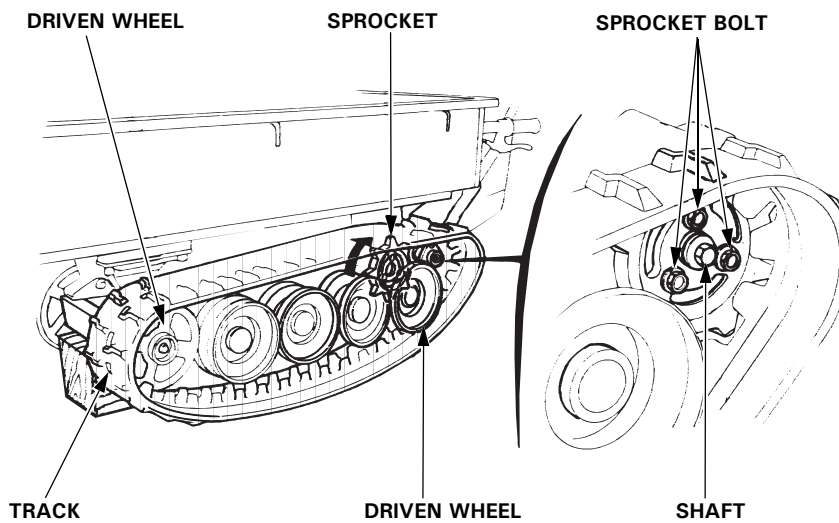

10. Remove the wooden blocks and make sure the power carrier is level. Then adjust the track tautness.

**CAUTION:**

- Special care should be exercised when mounting the tracks.
- Do not tip the carrier onto its side; oil and gasoline may spill out.
- After following the above temporary procedure, have the power carrier inspected by your authorized Honda dealer as soon as possible.

## 11. TRANSPORTING/STORAGE

When transporting or storing the power carrier, make sure the engine switch is in the OFF position and the spark plug cap is disconnected to prevent accidental engine start up.

### ▲WARNING

- To avoid severe burns or fire hazards, let the engine cool before transporting the power carrier or storing it indoors.
- When transporting the power carrier, turn the fuel valve to the OFF position, and keep the engine level to prevent fuel spillage. Spilled fuel or fuel vapor may ignite.

1. Draining off the gasoline.

### ▲WARNING

Gasoline is extremely flammable and is explosive under certain conditions. Do not smoke or allow flames or sparks in the area.

- a. Turn the fuel valve ON.
- b. Loosen the carburetor drain knob, and drain the gasoline into a suitable container. After draining, retighten the drain knob and turn the fuel valve OFF.

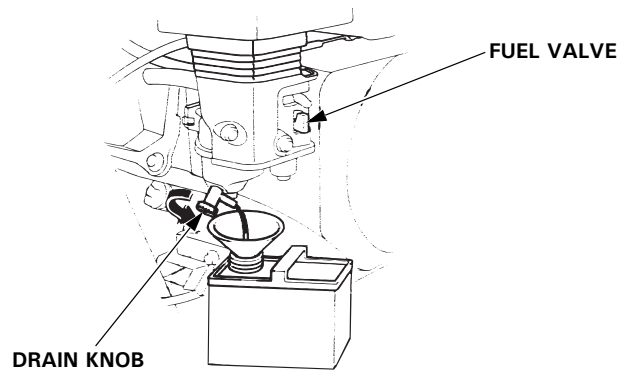

### ▲WARNING

- Keep all sparks and open flames away when draining the fuel.
- Perform the operation in a well-ventilated location.
- Dispose of the drained fuel properly.

2. Change the engine oil (see page 37 for details).
3. Clean the cleaner (see page 39 for details).
4. Clean the power carrier and inspect all parts to make sure they are securely tightened. Lubricate the points noted on page 46.

**NOTE:**

If the carrier will be stored for more than three months, remove the spark plug, pour one tablespoon of clean engine oil into the plug hole and reinstall the spark plug securely.

5. Pull the starter grip until you feel slight resistance.

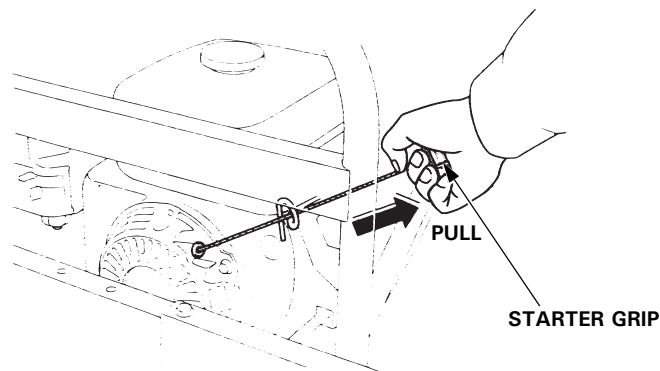

6. Place a cover over the power carrier or store it in a well-ventilated enclosed location.

**CAUTION:**

When storing the power carrier, first allow the engine exhaust system to cool off completely and then place the power carrier far from any combustible products.

### Hoisting procedure

- 1) Lower the entire load.
- 2) Make sure the engine switch and fuel valve are OFF.
- 3) Set the drive clutch levers in their lowered position and fix them in place with vinyl tape or other means.

### CAUTION:

**If the drive clutch levers are not fixed in place, deformation may occur at the rope contact points.**

- 4) Tie the hoisting rope to the base of the handle grips.
- 5) Tie the rope to the front of the carrier bracket.
- 6) Check the stability of the unit while hoisting.

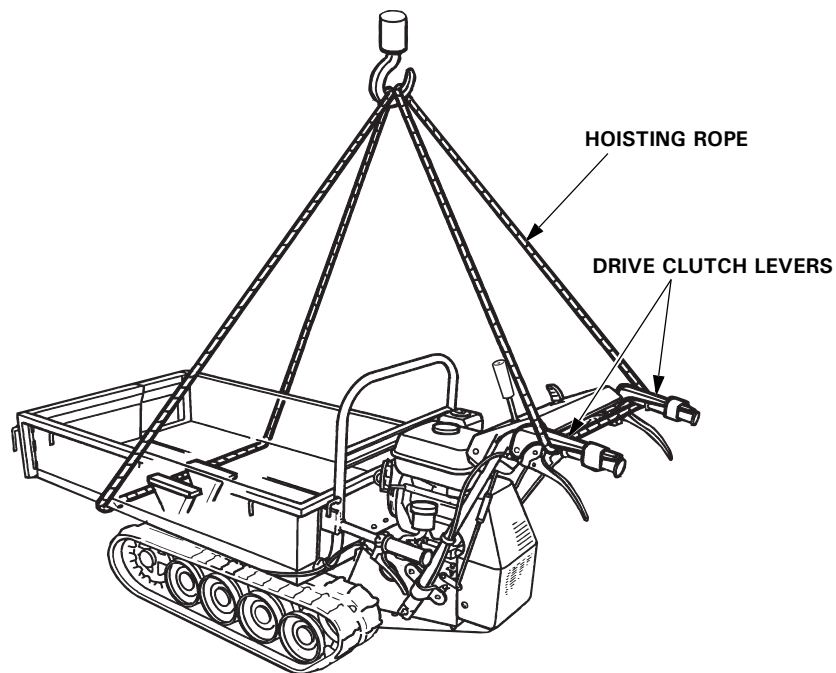

## 12. TROUBLESHOOTING

To assure maximum service life from your carrier, don't disassemble it unnecessarily. If the following basic troubleshooting does not get you and your carrier back to work, it is time to consult your authorized Honda dealer.

Check the following points if the engine does not start.

1. Is there sufficient fuel?
2. Is the fuel valve on?
3. Is gasoline reaching the carburetor?

To check, loosen the drain knob with the fuel valve on. Fuel should flow out freely. Retighten drain knob.

### ▲WARNING

**Gasoline is flammable and explosive under certain conditions. Do not smoke or allow flames or sparks near the equipment while draining fuel.**

4. Is the engine switch on?
5. Is the spark plug in good condition?

Remove and inspect the spark plug. Clean, readjust gap and dry the spark plug. Replace it if necessary.

6. Have you followed the starting method as described on page 19?
  - If the engine still does not start, take the carrier to an authorized Honda dealer.

Check the following if the engine runs but the carrier does not operate properly:

- Is the drive clutch cable adjusted (page 41)?
- Are the side clutch cables adjusted (page 44)?
- Is the brake cable properly adjusted (page 42)?
- Are the tracks adjusted to proper tautness (page 40)?

## 13. SPECIFICATIONS

Model	HP500H	
Description code	NZAA	
Type	NXE	BXE1

### Engine

Model	GX160
Engine type	4-stroke, overhead valve, 1 cylinder
Engine net power (in accordance with SAE J1349*)	3.6 kW (4.9 PS)/3,600 rpm
Displacement	163 cm <sup>3</sup> (9.9 cu-in)
Bore × stroke	68.0 × 45.0 mm (2.7 × 1.8 in)
Ignition system	Transistor magneto ignition
Engine oil capacity	0.58 L (0.61 US qt, 0.51 Imp qt)
Fuel tank capacity	3.1 L (0.82 US gal, 0.68 Imp gal)
Spark plug	BPR6ES (NGK) W20EPR-U (DENSO)

\* The power rating of the engine indicated in this document is the net power output tested on a production engine for the engine model and measured in accordance with SAE J1349 at 3,600 rpm (Engine Net Power). Mass production engines may vary from this value. Actual power output for the engine installed in the final machine will vary depending on numerous factors, including the operating speed of the engine in application, environmental conditions, maintenance, and other variables.



**Frame**

Type	NXE	BXE1
Overall length	1,730 mm (68.1 in)	2,140 mm (84.3 in)
Overall width	600 mm (23.6 in)	650 mm (25.6 in)
Overall height	1,100 mm (43.3 in)	
Dry mass [weight]	144 kg (317 lbs)	197 kg (434 lbs)
Fully supplied mass [weight]	147 kg (324 lbs)	200 kg (441 lbs)
No. of gears	Stepless (HST)	
Travelling speed	Forward 0–4.3 km/h Reverse 0–3.6 km/h	
Maximum weight	Level ground Sloping ground	500 kg (1,102 lbs) 350 kg (772 lbs)
Transmission oil capacity	2.3 L (2.4 US qt, 2.0 Imp qt)	
Track width × length	180 × 2,220 mm (7.1 × 87.4 in)	

**Noise and Vibration**

- Except for NXE type

MODEL	HP500H
Sound pressure level at operator's ears (EN ISO 11200: 1995)	83 dB (A)
Uncertainty	1 dB (A)
Measured sound power level (2000/14/EC, 2005/88/EC)	98 dB (A)
Uncertainty	1 dB (A)
Guaranteed sound power level (2000/14/EC, 2005/88/EC)	99 dB (A)
Vibration level at hand arm (EN1033: 1995)	2.9 m/s <sup>2</sup>
Uncertainty (EN12096: 1997 Annex D)	1.5 m/s <sup>2</sup>

**NOTE:**

Specifications are subject to change without notice due to improvements.

## **MAJOR Honda DISTRIBUTOR ADDRESSES**

For further information, please contact Honda Customer Information Centre at the following address or telephone number:

### **ADRESSES DES PRINCIPAUX CONCESSIONNAIRES Honda**

Pour plus d'informations, s'adresser au Centre d'informations clients Honda à l'adresse ou numéro de téléphone suivants:

### **ADRESSEN DER WICHTIGSTEN Honda-HAUPTHÄNDLER**

Weitere Informationen erhalten Sie gerne vom Honda-Kundeninformationszentrum unter der folgenden Adresse oder Telefonnummer:

### **DIRECCIONES DE LOS PRINCIPALES CONCESIONARIOS Honda**

Para obtener más información, póngase en contacto con el Centro de información para clientes Honda en la dirección o número de teléfono siguientes:

### **INDIRIZZI CONCESSIONARI Honda PRINCIPALI**

Per ulteriori informazioni rivolgersi al Centro informazioni clienti Honda al seguente indirizzo o numero telefonico:

## AUSTRIA

**Honda Austria GmbH**

Hondastraße 1  
2351 Wiener Neudorf  
Tel. : +43 (0)2236 690 0  
Fax : +43 (0)2236 690 480  
<http://www.honda.at>  
✉ [HondaPP@honda.co.at](mailto:HondaPP@honda.co.at)

## BALTIC STATES (Estonia/Latvia/ Lithuania)

**Honda Motor Europe Ltd.**

Estonian Branch  
Tulika 15/17  
10613 Tallinn  
Tel. : +372 6801 300  
Fax : +372 6801 301  
✉ [honda.baltic@honda-eu.com](mailto:honda.baltic@honda-eu.com)

## BELGIUM

**Honda Belgium**

Doornveld 180-184  
1731 Zellik  
Tel. : +32 2620 10 00  
Fax : +32 2620 10 01  
<http://www.honda.be>  
✉ [BH\\_PE@HONDA-EU.COM](mailto:BH_PE@HONDA-EU.COM)

## BULGARIA

**Kirov Ltd.**

49 Tsaritsa Yoana blvd  
1324 Sofia  
Tel. : +359 2 93 30 892  
Fax : +359 2 93 30 814  
<http://www.kirov.net>  
✉ [honda@kirov.net](mailto:honda@kirov.net)

## CROATIA

**Hongoldonia d.o.o.**

Jelkovecka Cesta 5  
10360 Sesvete — Zagreb  
Tel. : +385 1 2002053  
Fax : +385 1 2020754  
<http://www.hongoldonia.hr>  
✉ [jure@hongoldonia.hr](mailto:jure@hongoldonia.hr)

## CYPRUS

**Alexander Dimitriou & Sons  
Ltd.**

162, Yiannos Kranidiotis  
Avenue  
2235 Latsia, Nicosia  
Tel. : +357 22 715 300  
Fax : +357 22 715 400

## CZECH REPUBLIC

**BG Technik cs, a.s.**

U Zavodiste 251/8  
15900 Prague 5 - Velka  
Chuchle  
Tel. : +420 2 838 70 850  
Fax : +420 2 667 111 45  
<http://www.honda-stroje.cz>

## DENMARK

**Tima Products A/S**

Tårnfalkevej 16  
2650 Hvidovre  
Tel. : +45 36 34 25 50  
Fax : +45 36 77 16 30  
<http://www.tima.dk>

## FINLAND

**OY Brandt AB.**

Tuupakantie 7B  
01740 Vantaa  
Tel. : +358 20 775 7200  
Fax : +358 9 878 5276  
<http://www.brandt.fi>

## FRANCE

**Honda Relations Clients**

TSA 80627  
45146 St Jean de la Ruelle Cedex  
Tel. : 02 38 81 33 90  
Fax : 02 38 81 33 91  
<http://www.honda-fr.com>  
✉ [espaceclient@honda-eu.com](mailto:espaceclient@honda-eu.com)

## GERMANY

**Honda Deutschland  
GmbH**

Sprendlinger Landstraße 166  
63069 Offenbach am Main  
Tel. : 01 80 5/20 20 90  
Fax : +49 69 8320 20  
<http://www.honda.de>  
✉ [info@post.honda.de](mailto:info@post.honda.de)

## GREECE

**General Automotive Co S.A.**

71 Leoforos Athinon  
10173 Athens  
Tel. : +30 210 349 7809  
Fax : +30 210 346 7329  
<http://www.honda.gr>  
✉ [info@saracakis.gr](mailto:info@saracakis.gr)

## HUNGARY

**Motor Pedo Co., Ltd.**

Kamaraerdei ut 3.  
2040 Budaors

Tel. : +36 23 444 971

Fax : +36 23 444 972

<http://www.hondakisgepek.hu>

✉ [info@hondakisgepek.hu](mailto:info@hondakisgepek.hu)

## ICELAND

**Bernhard ehf.**

Vatnagardar 24-26  
104 Reykjavik

Tel. : +354 520 1100

Fax : +354 520 1101

<http://www.honda.is>

## IRELAND

**Two Wheels Ltd**

M50 Business Park, Ballymount  
Dublin 12

Tel. : +353 1 4381900

Fax : +353 1 4607851

<http://www.hondaireland.ie>

✉ [Service@hondaireland.ie](mailto:Service@hondaireland.ie)

## ITALY

**Honda Italia Industriale S.p.A.**

Via della Cecchignola, 5/7  
00143 Roma

Tel. : +848 846 632

Fax : +39 065 4928 400

<http://www.hondaitalia.com>

✉ [info.power@honda-eu.com](mailto:info.power@honda-eu.com)

## MALTA

**The Associated Motors**

**Company Ltd.**

New Street in San Gwakkinn Road  
Mriehel Bypass, Mriehel QRM17

Tel. : +356 21 498 561

Fax : +356 21 480 150

## NETHERLANDS

**Honda Nederland B.V.**

Afd, Power Equipment  
Capronilaan 1

1119 NN Schiphol-Rijk

Tel. : +31 20 7070000

Fax : +31 20 7070001

<http://www.honda.nl>

## NORWAY

**Berema AS**

P.O. Box 454  
1401 Ski

Tel. : +47 64 86 05 00

Fax : +47 64 86 05 49

<http://www.berema.no>

✉ [berema@berema.no](mailto:berema@berema.no)

## POLAND

**Aries Power Equipment Sp. z o.o.**

ul. Wroclawska 25  
01-493 Warszawa

Tel. : +48 (22) 861 43 01

Fax : +48 (22) 861 43 02

<http://www.ariespower.pl>

<http://www.mojahonda.pl>

✉ [info@ariespower.pl](mailto:info@ariespower.pl)

## PORTUGAL

**Honda Portugal, S.A.**

Rua Fontes Pereira de Melo 16  
Abrunheira, 2714-506 Sintra

Tel. : +351 21 915 53 33

Fax : +351 21 915 23 54

<http://www.honda.pt>

✉ [honda.produtos@honda-eu.com](mailto:honda.produtos@honda-eu.com)

## REPUBLIC OF BELARUS

**Scanlink Ltd.**

Kozlova Drive, 9  
220037 Minsk

Tel. : +375 172 999090

Fax : +375 172 999900

<http://www.hondapower.by>

## ROMANIA

**Hit Power Motor Srl**

Calea Giulesti N° 6-8 Sector 6  
060274 Bucuresti

Tel. : +40 21 637 04 58

Fax : +40 21 637 04 78

<http://www.honda.ro>

✉ [hit\\_power@honda.ro](mailto:hit_power@honda.ro)

## RUSSIA

**Honda Motor RUS LLC**

21. MKAD 47 km., Leninsky  
district.

Moscow region, 142784 Russia

Tel. : +7 (495) 745 20 80

Fax : +7 (495) 745 20 81

<http://www.honda.co.ru>

✉ [postoffice@honda.co.ru](mailto:postoffice@honda.co.ru)

## SERBIA & MONTENEGRO

**Bazis Grupa d.o.o.**  
Grcica Milenka 39  
11000 Belgrade  
Tel. : +381 11 3820 295  
Fax : +381 11 3820 296  
<http://www.hondasrbija.co.rs>

## SLOVAKIA REPUBLIC

**Honda Slovakia, spol. s r.o.**  
Prievozská 6 821 09 Bratislava  
Tel. : +421 2 32131112  
Fax : +421 2 32131111  
<http://www.honda.sk>

## SLOVENIA

**AS Domzale Moto Center D.O.O.**  
Blatnica 3A  
1236 Trzin  
Tel. : +386 1 562 22 42  
Fax : +386 1 562 37 05  
<http://www.as-domzale-motoc.si>

## SPAIN & Las Palmas province

(Canary Islands)  
**Greens Power Products, S.L.**  
Poligono Industrial Congost -  
Av Ramon Ciurans n°2  
08530 La Garriga - Barcelona  
Tel. : +34 93 860 50 25  
Fax : +34 93 871 81 80  
<http://www.hondaencasa.com>

## Tenerife province (Canary Islands)

**Automocion Canarias S.A.**  
Carretera General del Sur, KM. 8,8  
38107 Santa Cruz de Tenerife  
Tel. : +34 (922) 620 617  
Fax : +34 (922) 618 042  
<http://www.aucasa.com>  
✉ [ventas@aucasa.com](mailto:ventas@aucasa.com)  
✉ [taller@aucasa.com](mailto:taller@aucasa.com)

## SWEDEN

**Honda Nordic AB**  
Box 31002 - Långhusgatan 4  
215 86 Malmö  
Tel. : +46 (0)40 600 23 00  
Fax : +46 (0)40 600 23 19  
<http://www.honda.se>  
✉ [hpesinfo@honda-eu.com](mailto:hpesinfo@honda-eu.com)

## SWITZERLAND

**Honda Suisse S.A.**  
10, Route des Moulières  
1214 Vernier - Genève  
Tel. : +41 (0)22 939 09 09  
Fax : +41 (0)22 939 09 97  
<http://www.honda.ch>

## TURKEY

**Anadolu Motor Uretim ve  
Pazarlama AS**  
Esentepe mah. Anadolu  
Cad. No: 5  
Kartal 34870 Istanbul  
Tel. : +90 216 389 59 60  
Fax : +90 216 353 31 98  
<http://www.anadolumotor.com.tr>  
✉ [antor@antor.com.tr](mailto:antor@antor.com.tr)

## UKRAINE

**Honda Ukraine LLC**  
101 Volodymyrska Str. - Build. 2  
Kyiv 01033  
Tel. : +380 44 390 1414  
Fax : +380 44 390 1410  
<http://www.honda.ua>  
✉ [CR@honda.ua](mailto:CR@honda.ua)

## UNITED KINGDOM

**Honda (UK) Power Equipment**  
470 London Road  
Slough - Berkshire, SL3 8QY  
Tel. : +44 (0)845 200 8000  
<http://www.honda.co.uk>

**"EC Declaration of Conformity" CONTENT OUTLINE**  
**"CE-Déclaration de conformité" DESCRIPTION DE TABLE DES MATIERES**  
**"EU-Konformitätserklärung" INHALTSÜBERSICHT**  
**DESCRIPCIÓN GENERAL DEL CONTENIDO DE LA "Declaración de Conformidad CE"**  
**DESCRIZIONE DEL CONTENUTO DELLA "Dichiarazione CE di Conformità"**

**EC Declaration of Conformity**

1. The undersigned, Piet Renneboog, on behalf of the authorized representative, herewith declares that the machinery described below fulfils all the relevant provisions of:
- Directive 2006/42/EC on machinery
  - Directive 2004/108/EC on electromagnetic compatibility
  - Directive 2000/14/EC – 2005/88/EC on outdoor noise

2. Description of the machinery

a) Generic denomination: Dumper  
 b) Function: transport of goods

c) Commercial name	d) Type	e) Serial number
*1	*1	

3. Manufacturer

Honda Motor Co., Ltd.  
 2-1-1 Minamiaoyama  
 Minato-ku, Tokyo, JAPAN

4. Authorized representative

Honda Motor Europe Ltd. Aalst Office  
 Wijngaardveld 1 (Noord V),  
 9300 Aalst – BELGIUM

5. References to harmonized standards	6. Other standards or specifications
-	-

7. Outdoor noise Directive

a) Measured sound power dB(A): \*1  
 b) Guaranteed sound power dB(A): \*1  
 c) Noise parameter (kW/min<sup>-1</sup>): \*1  
 d) Conformity assessment procedure: ANNEX VI  
 e) Notified body: AIB-VINCOTTE International nv  
 Jan Olieslagerslaan 35  
 B-1800 Vilvoorde BELGIUM  
 Aalst , BELGIUM

8. Done at:

9. Date:

\_\_\_\_\_  
 Piet Renneboog  
 Homologation Manager  
 Honda Motor Europe, Ltd., Aalst Office

\*1: see specification page.

\*1: voir page de spécifications

\*1: Siehe Spezifikationen-Seite

\*1: consulte la página de las especificaciones

\*1: vedi la pagina delle caratteristiche tecniche

<p><b>Français (French)</b> Déclaration CE de Conformité</p> <p>1. Le sous signé, Piet Renneboog, de la part du représentant autorisé, déclare que la machine décrit ci-dessous répond à toutes les dispositions applicables de :</p> <ul style="list-style-type: none"> <li>* Directive Machine 2006/42/CE</li> <li>* Directive 2004/108/CE sur la compatibilité électromagnétique</li> <li>* Directive 2000/14/CE - 2005/88/CE des émissions sonores dans l'environnement des matériels destinés à être utilisés à l'extérieur des bâtiments</li> </ul> <p>2. Description de la machine</p> <p>a) Dénomination générique : Tombereau b) Fonction : transport de marchandises c) Nom Commercial d) Type e) Numéro de série</p> <p>3. Constructeur 4. Représentant autorisé 5. Référence aux normes harmonisées 6. Autres normes et spécifications 7. Directives des émissions sonores dans l'environnement des matériels destinés à être utilisés à l'extérieur des bâtiments</p> <p>a) Puissance acoustique mesurée b) Puissance acoustique garantie c) Paramètre du bruit d) Procédure d'évaluation de conformité</p> <p>e) Organisme notifié 8. Fait à 9. Date</p>	<p><b>Italiano (Italian)</b> Dichiarazione CE di Conformità</p> <p>1. Il sottoscritto, Piet Renneboog, in qualità di rappresentante autorizzato, dichiara qui di seguito che la macchina sotto descritta soddisfa tutte le disposizioni pertinenti delle:</p> <ul style="list-style-type: none"> <li>* Direttiva macchine 2006/42/CE</li> <li>* Direttiva sulla compatibilità elettromagnetica 2004/108/CE</li> <li>* Direttiva sulla emissione acustica delle macchine e attrezzature destinate a funzionare all'aperto 2000/14/CE - 2005/88/CE</li> </ul> <p>2. Descrizione della macchina</p> <p>a) Denominazione generica : Dumper b) Funzione : Trasporto di materiali c) Denominazione commerciale d) Tipo e) Numero di serie</p> <p>3. Costruttore 4. Rappresentante Autorizzato 5. Riferimento agli standard armonizzati 6. Altri standard o specifiche 7. Direttiva sulla emissione acustica delle macchine e attrezzature destinate a funzionare all'aperto</p> <p>a) Livello di potenza sonora misurato b) Livello di potenza sonora garantito c) Parametri emissione acustica d) Procedura di valutazione della conformità e) Organismo notificato</p> <p>8. Fatto a 9. Data</p>	<p><b>Deutsch (German)</b> EG-Konformitätserklärung</p> <p>1. Der Unterzeichner, Piet Renneboog erklärt hiermit im Namen der Bevollmächtigten, dass das hierunter genannte Maschine allen einschlägigen Bestimmungen der * entspricht.</p> <ul style="list-style-type: none"> <li>* Maschinenrichtlinie 2006/42/EG</li> <li>* Richtlinie der Elektromagnetischen Kompatibilität 2004/108/EG</li> <li>* Geräuschrichtlinie im Freien 2000/14/EG - 2005/88/EG</li> </ul> <p>2. Beschreibung der Maschine</p> <p>a) Allgemeine Bezeichnung: Muldenkipper b) Funktion: Gegenstände transportieren c) Handelsbezeichnung d) Typ e) Seriennummer 3. Hersteller 4. Bevollmächtigter 5. Verweis auf harmonisierte Normen 6. Andere Normen oder Spezifikationen 7. Geräuschrichtlinie im Freien</p> <p>a) Gemessene Lautstärke b) Schalleistungspegel c) Geräuschvorgabe d) Konformitätsbewertungs Ablauf e) Benannte Stelle</p> <p>8. Ort 9. Datum</p>
<p><b>Nederlands (Dutch)</b> EG-verklaring van overeenstemming</p> <p>1. Ondergetekende, Piet Renneboog, in naam van de gemachtigde van de fabrikant, verklaart hiermee dat het hieronder beschreven machine voldoet aan alle toepasselijke bepalingen van :</p> <ul style="list-style-type: none"> <li>* Richtlijn 2006/42/EG betreffende machines</li> <li>* Richtlijn 2004/108/EG betreffende elektromagnetische overeenstemming</li> <li>* Richtlijn 2000/14/EG - 2005/88/EG betreffende geluidsemissie (openlucht)</li> </ul> <p>2. Beschrijving van de machine</p> <p>a) Algemene benaming : Transportwagen b) Functie : goederen transporteren c) Handelsbenaming d) Type e) Serienummer 3. Fabrikant 4. Gemachtigde van de fabrikant 5. Refereert naar geharmoniseerde normen 6. Andere normen of specificaties 7. Geluidsemissierichtlijn (openlucht)</p> <p>a) Gemeten geluidsvermogensniveau b) Gewaarborgd geluidsvermogensniveau c) Geluidparameter d) Conformiteitsbeoordelingsprocedure e) Aangemelde instantie</p> <p>8. Plaats 9. Datum</p>	<p><b>Dansk (Danish)</b> EF OVERENSTEMMELSEERKLÆRING</p> <p>1. UNDERTEGNEDE, PIET RENNEBOOG, PÅ VEGNE AF DEN AUTORISEREDE REPRÆSENTANT, ERKLÆRER HERMED AT MASKINEN, SOM ER BESKREVET NEDENFOR, OPFYLDER ALLE RELEVANTE BESTEMMELSER IFØLGE:</p> <ul style="list-style-type: none"> <li>* MASKINDIREKTIV 2006/42/EF</li> <li>* EMC-DIREKTIV 2004/108/EF</li> <li>* DIREKTIV OM STØJEMISSION 2000/14/EF - 2005/88/EF</li> </ul> <p>2. BESKRIVELSE AF PRODUKTET</p> <p>a) FELLESBETEGNELSE : Dumper b) ANVENDELSE : Godstranport c) HANDELSBETEGNELSE d) TYPE e) SERIENUMMER</p> <p>3. PRODUCENT 4. AUTORISERET REPRÆSENTANT 5. REFERENCE TIL HARMONISEREDE STANDARDER 6. ANDRE STANDARDER ELLER SPECIFIKATIONER</p> <p>7. DIREKTIV OM STØJEMISSION FRA MASKINER</p> <p>a) MÅLT LYDEFFEKTNIVEAU b) GARANTERET LYDEFFEKTNIVEAU c) STØJPARAMETER d) PROCEDURE FOR OVERENSSTEMMELSESVURDERING e) BEMYNDIGET ORGAN</p> <p>8. STED 9. DATO</p>	<p><b>Ελληνικά (Greek)</b> ΕΚ-Δήλωση συμμόρφωσης</p> <p>1. Ο κάτωθι υπογεγραμμένος, Piet Renneboog, εκ μέρους του εξουσιοδοτημένου αντιπροσώπου με το παρών δηλώνει ότι το παρακάτω περιγραφόμενο όχημα πληροί όλες τις σχετικές προδιαγραφές του:</p> <ul style="list-style-type: none"> <li>* Οδηγία 2006/42/ΕΚ για μηχανές</li> <li>* Οδηγία 2004/108/ΕΚ για την ηλεκτρομαγνητική συμβατότητα</li> <li>* Οδηγία 2000/14/ΕΚ - 2005/88/ΕΚ για το επίπεδο θορύβου σε εξωτερικούς χώρους.</li> </ul> <p>2. Περιγραφή μηχανήματος</p> <p>a) Γενική ονομασία : Ανατρεπόμενο όχημα b) Λειτουργία : για μεταφορά αγαθών c) Εμπορική ονομασία d) Τύπος e) Αριθμός σειράς παραγωγής 3. Κατασκευαστής 4. Εξουσιοδοτημένος αντιπρόσωπος 5. Αναφορά σε εναρμονισμένα πρότυπα 6. Λοιπά πρότυπα ή προδιαγραφές 7. Οδηγία επιπέδου θορύβου εξωτερικών χώρων</p> <p>a) Μετρηθέντα ηχητικά ένταση b) Εγγυημένη ηχητική ένταση c) Ηχητική παράμετρος d) Διαδικασία πιστοποίησης e) Οργανισμός πιστοποίησης</p> <p>8. Η δοκιμή έγινε 9. Ημερομηνία</p>
<p><b>Svenska (Swedish)</b> EG-försäkran om överensstämmelse</p> <p>1. Undertecknad, Piet Renneboog, på uppdrag av auktoriserad representant, deklarerar härmed att maskinen beskriven nedan fullföljer alla relevanta bestämmelser enl :</p> <ul style="list-style-type: none"> <li>* Direktiv 2006/42/EG gällande maskiner</li> <li>* Direktiv 2004/108/EG gällande elektromagnetisk kompatibilitet</li> <li>* Direktiv 2000/14/EG - 2005/88/EG gällande buller utomhus</li> </ul> <p>2. Maskinbeskrivning</p> <p>a) Allmän benämning : Dumper b) Funktion : godstransport c) Och varunamn d) Typ e) Serienummer 3. Tillverkare 4. Auktoriserad representant 5. referens till överensstämmande standarder 6. Andra standarder eller specifikationer 7. Direktiv för buller utomhus</p> <p>a) Uppmått ljudnivå b) Garanterad ljudnivå c) Buller parameter d) Förfarande för bedömning e) Anmälda organ</p> <p>8. Utfärdad vid 9. Datum</p>	<p><b>Español (Spanish)</b> Declaración de Conformidad CE</p> <p>1. El abajo firmante, Piet Renneboog, en representación del representante autorizado, adjunto declara que la máquina abajo descrita, cumple las cláusulas relevantes de:</p> <ul style="list-style-type: none"> <li>* Directiva 2006/42/CE de maquinaria</li> <li>* Directiva 2004/108/CE de compatibilidad electromagnética</li> <li>* Directiva 2000/14/CE - 2005/88/CE de ruido exterior</li> </ul> <p>2. Descripción de la máquina</p> <p>a) Denominación genérica : Carretilla todo terreno b) Función : Transportar materiales c) Denominación comercial d) Tipo e) Número de serie</p> <p>3. Fabricante 4. Representante autorizado 5. Referencia de los estándar armonizados 6. Otros estándar o especificaciones 7. Directiva sobre ruido exterior</p> <p>a) Potencia sonora Medida b) Potencia sonora Garantizada c) Parámetros ruido d) Procedimiento evaluación conformidad e) Organismo notificado</p> <p>8. Realizado en 9. Fecha</p>	<p><b>Română (Romanian)</b> CE -Declarație de Conformitate</p> <p>1. Subsemnatul Piet Renneboog, in numele reprezentantului autorizat, declar prin prezenta faptul ca echipamentul descris mai jos indeplineste toate conditiile necesare din:</p> <ul style="list-style-type: none"> <li>* Directiva 2006/42/CE privind echipamentul</li> <li>* Directiva 2004/108/CE privind compatibilitatea electromagnetica</li> <li>* Directiva 2000/14/CE - 2005/88/CE privind poluarea fonica in spatiu deschis</li> </ul> <p>2. Descrierea echipamentului</p> <p>a) Denumire generica : Transportor pe senile b) Domeniu de utilizare : transportul produselor c) Denumire comerciala d) Tip e) Serie produs 3. Producator 4. Reprezentantul Autorizat 5. Referinta la standardele armonizate 6. Alte standarde sau norme 7. Directiva privind poluarea fonica in spatiu inchis</p> <p>a) Puterea acustica masurata b) Puterea acustica maxim garantata c) Indice poluare fonica d) Procedura de evaluare a conformitatii e) Notificari</p> <p>8. Emisa la 9. Data</p>

<p><b>Português ( Portuguese )</b>  Declaración CE de Conformidade  1. O abaixo assinado, Piet Renneboog, declara deste modo, em nome do mandatário, que o máquina abaixo descrito cumpre todas as estipulações relevantes da:</p> <ul style="list-style-type: none"> <li>* Directiva 2006/42/CE de máquina</li> <li>* Directiva 2004/108/CE de compatibilidade electromagnética</li> <li>* Directiva 2000/14/CE - 2005/88/CE de ruído exterior</li> </ul> <p>2. Descrição da máquina  a) Denominação genérica : Carro de transporte  b) Função : transporte de bens  c) Marca  d) Tipo  e) Número de série  3. Fabricante  4. Mandatário  5. Referência a normas harmonizadas  6. Outras normas ou especificações  7. Directiva de ruído exterior  a) Potência sonora medida  b) Potência sonora garantida  c) Parametro de ruído  d) Procedimento de avaliação da conformidade  e) Organismo notificado  8. Feito em  9. Data</p>	<p><b>Polski ( Polish )</b>  Deklaracja zgodności WE  1. Niżej podpisany, Piet Renneboog, w imieniu upoważnionego przedstawiciela, niniejszym deklaruje, że urządzenie opisane poniżej spełnia wszystkie odpowiednie postanowienia:</p> <ul style="list-style-type: none"> <li>* Dyrektywa Maszynowa 2006/42/WE</li> <li>* Dyrektywa Kompatybilności Elektromagnetycznej 2004/108/WE</li> <li>* Dyrektywa Hałasowa 2000/14/WE - 2005/88/WE</li> </ul> <p>2. Opis urządzenia  a) Ogólne określenie : Wywrotka  b) Funkcja : transportowanie  c) Nazwa handlowa  d) Typ  e) Numery seryjne  3. Producent  4. Upoważniony Przedstawiciel  5. Zastosowane normy zharmonizowane  6. Pozostałe normy i przepisy  7. Dyrektywa Hałasowa  a) Zmierzony poziom mocy akustycznej  b) Gwarantowany poziom mocy akustycznej  c) Wartość hałasu  d) Procedura oceny zgodności  e) Jednostka notyfikowana  8. Miejsce  9. Data</p>	<p><b>Suomi / Suomen kieli ( Finnish )</b>  EY-VAAITIMUSTENMUKAISUUSVAKUUTUS  1. Allekirjoittanut, Piet Renneboog valituttu valmistajan edustaja, vakuuttaa täten että alla mainittu kone/tuote täyttää kaikki seuraavia määräyksiä:</p> <ul style="list-style-type: none"> <li>* Koneidirektiivi 2006/42/EY</li> <li>* Direktiivi 2004/108/EY sähkömagnettinen yhteensopivuus</li> <li>* Direktiivi 2000/14/EY - 2005/88/EY ympäristön melu</li> </ul> <p>2. TUOTTEEN KUVAUS  a) Yleisarvomäärä : Dumpperi  b) Toiminto : esineiden kuljetus  c) KAUPALLINEN NIMI  d) TYYPPI  e) SARJANUMERO  3. VALMISTAJA  4. VALMISTAJAN EDUSTAJAN  5. VIITTAUS YHTEISIIN STANDARDEIHIN  6. MUU STANDARDI TAI TEKNISET TIEDOT  7. Ympäristön meludirektiivi  a) Mittauksen melutaso  b) Todenmukainen melutaso  c) Melu parametrit  d) Yhdenmukaisuuden arvioinnin menetelmä  e) Tiedonantolin  8. TEHTY  9. PÄIVÄMÄÄRÄ</p>
<p><b>Magyar ( Hungarian )</b>  EK-megfelelőségi nyilatkozata  1. Alulírott Piet Renneboog, a gyártó cég törvényes képviselőjeként nyilatkozom, hogy az általunk gyártott gép megfelel az összes, alább felsorolt direktívának:</p> <ul style="list-style-type: none"> <li>* 2006/42/EK Direktívának berendezésekre</li> <li>* 2004/108/EK Direktívának elektromágneses megfeleléségre</li> <li>* 2000/14/EK - 2005/88/EK Direktívának kültéri zajszintre</li> </ul> <p>2. A gép leírása  a) Általános megnevezés : Dömpfer  b) Funkció : javak szállítása  c) Kereskedelmi név  d) Típus  e) Sorozatszám  3. Gyártó  4. Jogosult képviselő  5. Hivatkozással a szabványokra  6. Más előírások, megjegyzések  7. Kültéri zajszint Direktíva  a) Mért hangerő  b) Szavatolt hangerő  c) Zajszint paraméter  d) Megfelelőségi becslési eljárás  e) Kijelölt szervezet  8. Keltezés helye  9. Keltezés ideje</p>	<p><b>Cestina ( Czech )</b>  ES – Prohlášení o shodě  1. Podepsaný Piet Renneboog, jako autorizovaná osoba zde potvrzuje, že stroj popsaný níže splňuje požadavky příslušných opatření:</p> <ul style="list-style-type: none"> <li>* Směrnice 2006/42/ES pro strojní zařízení</li> <li>* Směrnice 2004/108/ES stanovující technické požadavky na výrobky z hlediska elektromagnetické kompatibility</li> <li>* Směrnice 2000/14/ES - 2005/88/ES stanovující technické požadavky na výrobky z hlediska emisí hluku zařízení pro venkovní použití</li> </ul> <p>2. Popis zařízení  a) Všeobecné označení : Dömpfr  b) Funkce : Přeprava nákladu  c) Obchodní název  d) Typ  e) Výrobní číslo  3. Výrobce  4. Autorizovaná osoba  5. Odkazy na harmonizované normy  6. Ostatní použité normy a specifikace  7. Směrnice pro hluk pro venkovní použití  a) Naměřený akustický výkon  b) Garantovaný akustický výkon  c) Parametr hluku  d) Způsob posouzení shody  e) Notifikovaná osoba  8. Podepsáno v  9. Datum</p>	<p><b>Latviešu ( Latvian )</b>  EK atbilstības deklarācija  1. Piet Renneboog ar savu parakstu zem šī dokumenta, autorizētā pārstāvja vārdā, paziņo, ka zemāk aprakstītie mašīna, atbilst visām zemāk norādīto direktīvu sadajām:</p> <ul style="list-style-type: none"> <li>* Direktīva 2006/42/EK par mašīnām</li> <li>* Direktīva 2004/108/EK attiecībā uz elektromagnētisko savietojamību</li> <li>* Direktīva 2000/14/EK - 2005/88/EK par trokšņa emisiju vidē</li> </ul> <p>2. Iekārtas apraksts  a) Vispārējais nosaukums : Kravas transportieris pašizgāzējs  b) Funkcija : kravu transportēšana  c) Komerccnosaukums  d) Tips  e) Sērijas numurs  3. Ražotājs  4. Autorizētais pārstāvis  5. Atsauc uz saskaņotajiem standartiem  6. Citi noteiktie standarti vai specifikācijas  7. Ārējo trokšņu Direktīva  a) Izmērītā trokšņa līelums  b) Pieļaujams trokšņa līelums  c) Trokšņa parametri  d) Atbilstības vērtējuma procedūra  e) Informētā iestāde  8. Vieta  9. Datums</p>
<p><b>Slovenčina ( Slovak )</b>  ES vyhlásenie o zhode  1. Dolupodpísaný, Piet Renneboog, ako autorizovaný zástupca výrobcu, týmto vyhlasuje, že uvedeny strojev je v zhode s nasledovnymi smernicami:</p> <ul style="list-style-type: none"> <li>* Smernica 2006/42/ES (Strojné zariadenia)</li> <li>* Smernica 2004/108/ES (Elektromagnetická kompatibilita)</li> <li>* Smernica 2000/14/ES - 2005/88/ES (Emisie hluku)</li> </ul> <p>2. Popis stroja  a) Druhové označenie : Vykłapač  b) Funkcia : Transport nákladu  c) Obchodný názov  d) Typ  e) Výrobné číslo  3. Výrobca  4. Autorizovaný zástupca  5. Referencia k harmonizovaným štandardom  6. Daľšie štandardy alebo špecifikácie  7. Smernica pre emisie hluku vo voľnom priestranstve  a) Nameraná hladina akustického výkonu  b) Zarúčená hladina akustického výkonu  c) Rozmer  d) Procedúra posudzovania zhody  e) Notifikovaná osoba  8. Miesto  9. Dátum</p>	<p><b>Eesti ( Estonian )</b>  EÜ vastavusdeklaratsioon  1. Käesolevaga kinnitab allkirjutajana, Piet Renneboog, volitatud esindaja nimel, et allpool kirjeldatud masina vastab kõikidele alljärgnevat direktiivide sätetele:</p> <ul style="list-style-type: none"> <li>* Masinate direktiiv 2006/42/EÜ</li> <li>* Elektromagnetilise ühilduvuse direktiiv 2004/108/EÜ</li> <li>* Välistatud direktiiv 2000/14/EÜ - 2005/88/EÜ</li> </ul> <p>2. Seadmete kirjeldus  a) Üldnimetus : Pinnaseveok  b) Funktsioon : kaupade transport  c) Kaubanduslik nimetus  d) Tüüp  e) Seerianumber  3. Tootja  4. Volitatud esindaja  5. Viide ühtlustatud standarditele  6. Muud standardid ja spetsifikatsioonid  7. Välistatud direktiiv  a) Mõõdetud helivõimsuse tase  b) Lubatud helivõimsuse tase  c) Mõõde  d) Vastavusthindamismenetlus  e) Teavitatud asutus  8. Koht  9. Kuupäev</p>	<p><b>Slovensčina ( Slovenian )</b>  ES izjava o skladnosti  1. Spodaj podpisani, Piet Renneboog, ki je pooblaščen oseba in v imenu proizvajalca izjavlja, da spodaj opisana stroj ustreza vsem navedenim direktivam:</p> <ul style="list-style-type: none"> <li>* Direktiva 2006/42/ES o strojih</li> <li>* Direktiva 2004/108/ES o elektromagnetni združljivosti</li> <li>* Direktiva 2000/14/ES - 2005/88/ES o hrupnosti</li> </ul> <p>2. Opis naprave  a) Vrsta stroja : Transporter  b) Funkcija : transportiranje  c) Trgovski naziv  d) Tip  e) Serijska številka  3. Proizvajalec  4. Pooblaščen predstavnik  5. Upoštevanji harmonizirani standardi  6. Ostali standardi ali specifikaciji  7. Direktiva o hrupnosti  a) Izmerjena zvočna moč  b) Garantirana zvočna moč  c) Parametri  d) Postopek  e) Postopek opravi  8. Kraj  9. Datum</p>



<p><b>Lietuvių kalba (Lithuanian)</b>  <b>EB atitikties deklaracija</b>  1. Įgaliotojo atstovo vardu pasirašęs Piet Renneboog patvirtina, kad žemiau aprašyta mašina atitinka visas išvardintų direktyvų nuostatas:  * Mechanizmų direktyva 2006/42/EB  * Elektromagnetinio suderinamumo direktyva 2004/108/EB  * Triukšmo lauke direktyva 2000/14/EB - 2005/88/EB  2. Prietaiso aprašymas  a) Bendras pavadinimas : Dumperis  b) Funkcija : prekių transportavimas  c) Komercinis pavadinimas d) Tipas  e) Serijos numeris  3. Gamintojas  4. Įgaliotasis atstovas  5. Nuorodos į suderintus standartus  6. Kiti standartai ir specifikacija  7. Triukšmo lauke direktyva  a) Išmatuotas garso galingumo lygis  b) Garantuojamas garso galingumo lygis  c) Triukšmo parametras  d) Tipas  e) Registruota įstaiga  8. Vieta 9. Data</p>	<p><b>Български (Bulgarian)</b>  <b>ЕО декларация за съответствие</b>  1. Дуплодписаният Пайът Ренебург, от името на упълномощения представител, с настоящото декларирам, че машините, описани по-долу, отговарят на всички съответни разпоредби на:  * Директива2006/42/ЕО относно машините  * Директива 2004/108/ЕО относно електромагнитната съвместимост  Директива 2000/14/ЕО - 2005/88/ЕО относно шумовите емисии на съоръжения, предназначени за употреба извън сградите  2. Описание на машините  a) Общо наименование : Самосвал  b) Функция : превоз на стоки  c) Търговско наименование d) Тип  e) Серийен номер  3. Производител  4. Упълномощен представител  5. Съответствие с хармонизирани стандарти  6. Други стандарти или спецификации  7. Директива относно шумовите емисии на съоръжения, предназначени за употреба извън сградите  a) Измерена звукова мощност  b) Гарантирана звукова мощност  c) Параметърът шум  d) Процедурата за оценка на съответствието  e) Нотифициран орган  8. Място на изготвяне 9. Дата на изготвяне</p>	<p><b>Norsk (Norwegian)</b>  <b>EF- Samsvarserklæring</b>  1.Undertegnede Piet Renneboog på vegne av autorisert representant herved erklærer at maskineri beskrevet nedenfor innfrir relevant informasjon fra følgende forskrifter.  * Maskindirektivet 2006/42/EF  * Direktiv EMC: 2004/108/EF  <b>Elektromagnetisk kompatibilitet</b>  * Direktiv om støyt utendørs 2000/14/EF - 2005/88/EF  2. Beskrivelse av produkt  a) Felles benevnelse : Henger med topp  b) Funksjon : Transportere varer  c) Handelsnavn d) Type  e) Serienummer  3. Produsent  4. Autorisert representant  5. Referanse til harmoniserte standarder  6. Øvrige standarder eller spesifikasjoner  7. Utendørs direktiv får støyt  a) Målt støyt  b) Maks støyt  c) Konstant støyt  d) Verdi vurderings prosedyre  e) Gjeldene kjøretøy/kropp/stamme/skrog  8. Sted 9. Dato</p>
<p><b>Türk (Turkish)</b>  <b>AT Uygunluk Beyanı</b>  1. Aşağıda imzası bulunan Piet Renneboog, yetkili temsilci adına, bu yazıyla birlikte aşağıdaki makine ile ilgili tüm hükümlülüklerin yerine getirildiğini beyan etmektedir:  * Makina Emriyet Yönetmeliği 2006/42/AT  * Elektromanyetik Uyumluluk Yönetmeliği 2004/108/AT  * Açık Alanda Kullanılan Teçhizat Tarafından Oluşturulan Çevredeki Gürültü Emisyonu İle İlgili Yönetmelik 2000/14/AT-2005/88/AT  2. Makinanın tanıtı  a) Kapsamlı adlandırma : Damper  b) İşlevi : Malzeme taşınması  c) Ticari adı d) Tipi  e) Seri numarası  3. İmalatçı  4. Yetkili temsilci  5. Uymlaştırılmış standartlara atf  6. Diğer standartlar veya spesifikasyonlar  7. Açık alan gürültü Yönetmeliği  a) Ölçülen ses gücü  b) Garantii edilen ses gücü  c) Gürültü parametresi  d) Uygunluk değerlendirme prosedürü  e) Onaylanmış kuruluş  8. Beyanın yeri : 9. Beyanın tarihi :</p>	<p><b>Íslenska (Icelandic)</b>  <b>EB-Samræmisvirkisýsing</b>  1. Undirritaður Piet Renneboog staðfestir hér með fyrir hönd löggilttra aðila að upplýsingar um vélbúnað hér að neðan eru tæmandi hvað varðar alla tilheyrandi málaflokkka, svo sem  *Leiðbeiningar fyrir vélbúnað 2006/42/EB  *Leiðbeiningar fyrir rafsegulsvið 2004/108/EB  *Leiðbeiningar um hávaðamengun 2000/14/EB-2005/88/EB  2. Lýsing á vélbúnaði  a) Flokkur : Vélknúinn vörupallur  b) Virkni : Flutningur á vörum  c) Nafn d) Tegund  e) Séríal númer  3. Framleiðandi  4. Löggildir aðilar  5. Tilvísun um heildar staðal  6. Aðrir staðlar eða sérstöður  7. Leiðbeiningar um hávaðamengun  a) Mældur hávaði styrkur  b) Staðfestur hávaði styrkur  c) Hávaði breytileiki  d) Staðfesting á gæðastöðlum  e) Merkingar  8. Gert hjá 9. Dagssetning</p>	<p><b>Hrvatski(Croatian)</b>  <b>EK Izjava o sukladnosti</b>  1. Polipisani, Piet Renneboog, u ime ovlaštenog predstavnika, ovime izjavljuju da strojevi navedeni u nastavku ispunjavaju sve važne odredbe:  * Propisa za strojeve 2006/42/EK  * Propisa o elektromagnetskoj kompatibilnosti 2004/108/EK  * Propisa o buci na otvorenome 2000/14/EK-2005/88/EK  2. Opis strojeva  a) Opća vrijednost : Transportna kolica  b) Funkcionalnost : prijevoz tereta  c) Komercijalni naziv d) Tip  e) Serijski broj  3. Proizvođač  4. Ovlašteni predstavnik  5. Reference na usklađene norme  6. Ostale norme i specifikacije  7. Propis o buci na otvorenome  a) Izmjerena jačina zvuka  b) Zajamčena jačina zvuka  c) Parametar buke  d) Postupak za ocjenu sukladnosti  e) Obavješteno tijelo  8. U 9. Datum</p>