

**Incorrect or out of phase engine timing can result in damage to the valves. The Tool Connection cannot be held responsible for any damage caused by using these tools in anyway.**

### **Safety Precautions – Please read**

- Disconnect the battery earth leads (check radio code is available)
- Remove spark or glow plugs to make the engine turn easier
- Do not use cleaning fluids on belts, sprockets or rollers
- Always make a note of the route of the auxiliary drive belt before removal
- Turn the engine in the normal direction (clockwise unless stated otherwise)
- Do not turn the camshaft, crankshaft or diesel injection pump once the timing chain has been removed (unless specifically stated)
- Do not use the timing chain to lock the engine when slackening or tightening crankshaft pulley bolts
- Do not turn the crankshaft or camshaft when the timing belt/chain has been removed
- Mark the direction of the chain before removing
- It is always recommended to turn the engine slowly, by hand and to re-check the camshaft and crankshaft timing positions.
- Crankshafts and Camshafts may only be turned with the chain drive mechanism fully installed.
- Do not turn crankshaft via camshaft or other gears
- Check the diesel injection pump timing after replacing the chain
- Observe all tightening torques
- Always refer to the vehicle manufacturer's service manual or a suitable proprietary instruction book
- Incorrect or out of phase engine timing can result in damage to the valves
- It is always recommended to turn the engine slowly, by hand, and to re-check the camshaft and crankshaft timing positions

# LASER®

Part No. 3581

Opel | Vauxhall | Saab

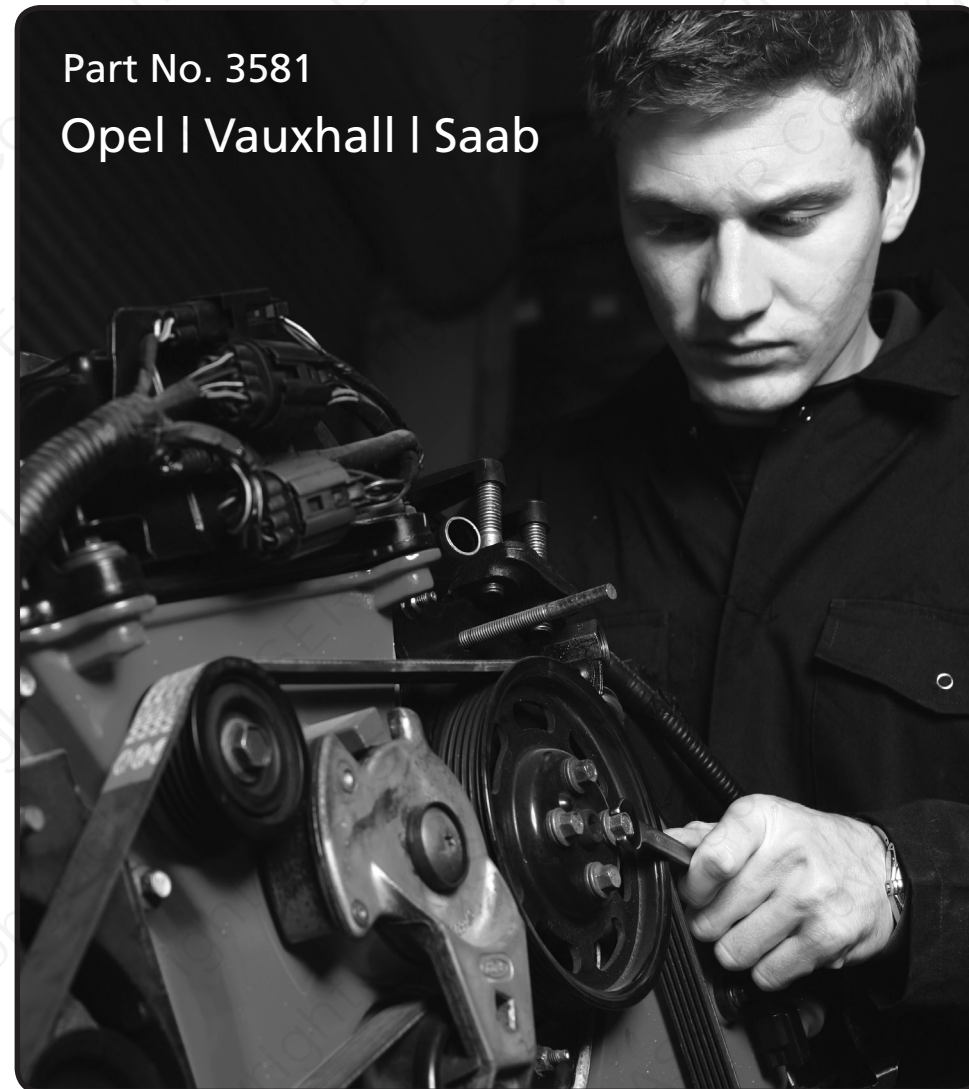

www.lasertools.co.uk



Guarantee



Distributed by The Tool Connection Ltd  
Kington Road, Southam, Warwickshire CV47 0DR  
T +44 (0) 1926 815000 F +44 (0) 1926 815888  
info@toolconnection.co.uk www.toolconnection.co.uk

If this product fails through faulty materials or workmanship, contact our service department direct on: +44 (0) 1926 818186. Normal wear and tear are excluded as are consumable items and abuse.

[www.lasertools.co.uk](http://www.lasertools.co.uk)

[www.lasertools.co.uk](http://www.lasertools.co.uk)

## Plan Layout

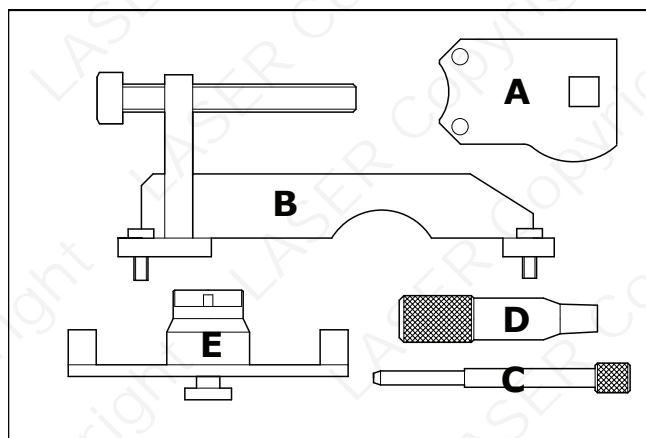
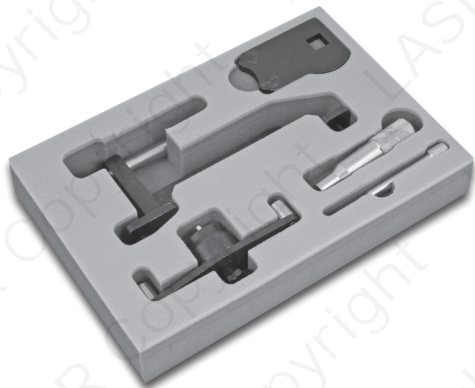

| Ref | Code | Oem Code            | Description                        |
|-----|------|---------------------|------------------------------------|
| A   | C169 | KM-933<br>83 95 394 | Timing Adjustment Wrench           |
| B   | C170 | KM-933<br>83 95 394 | Timing Adjustment Bracket Assembly |
| C   | C171 | KM-927<br>83 95 337 | Injection Pump Timing Pin          |
| D   | C172 | KM-929<br>83 95 352 | Crankshaft TDC Setting Pin         |
| E   | C173 | KM-932<br>83 95 386 | Camshaft Setting Plate             |

## Instruction (DE)

Die richtige Motorsteuerungsstellung wird erreicht, wenn sich der erste Zylinder bei OT befindet und jedes der Einstellwerkzeuge richtig eingesetzt werden kann.

1. Die Nockenwelle wird waagrecht mit Passloch oben positioniert. Das Nockenwellen-Einstellwerkzeug (E) zum Ausrichten der Nockenwelle verwenden (siehe Abb. 1).
2. Der Einspritzpumpen-Einstellstift (C) fluchtet mit einer Einstellmarkierung am Kettenrad und wird durch eine Aussparung im Einspritzpumpenflansch und die Befestigungsbohrung gesteckt. (siehe Abb. 2)
3. Der Kurbelwellen-Fixierdorn (D) wird zum Einstellen der Kurbelwelle in der OT-Stellung verwendet. Dieses Werkzeug wird durch die Öffnung für den Kurbelwellen-Impulsnehmer im Motorblock eingesteckt und sitzt in einem Schlitz in der Kurbelwelle. (siehe Abb. 3)
4. Das Einstellwerkzeug für das Einspritzpumpen-Kettenrad- (A+B) ermöglicht eine Einstellung der richtigen Motorsteuerungsstellung durch Maßnahmen an der Simplex-Kette und dem Nockenwellenrad. Zuerst den Doppelzapfenschlüssel vertikal am Kettenrad anbringen, dann das Hilfswerkzeug am Zylinderkopf befestigen. Mit einem 1/2"-Vierkantschrauber einen geringen Druck zum Drehen der Nockenwelle im Gegenuhrzeigersinn anwenden (gegen die Motordrehrichtung). Die Schraube wird dann gedreht, bis sie den Doppelzapfenschlüssel berührt, und in dieser Stellung belassen. (siehe Abb. 4)
5. Jetzt muss der Einspritzpumpen-Fixierdorn (C) locker sitzen und entfernt und wieder eingesteckt werden können. Wenn dieser Dorn fest sitzt, die Schraube einstellen, bis sich der Dorn leicht entfernen lässt. Die Schraube des Nockenwellenrads kann jetzt festgezogen und der Simplex-Ketten-Spanner wieder montiert werden.

Fig. 1

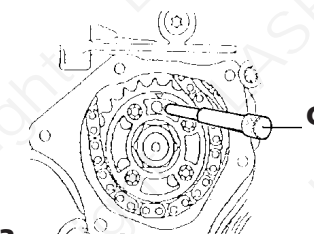
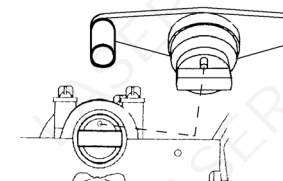
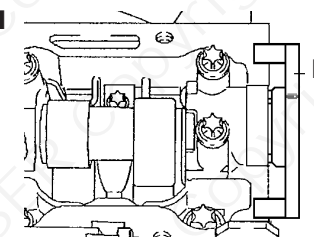

Fig. 3

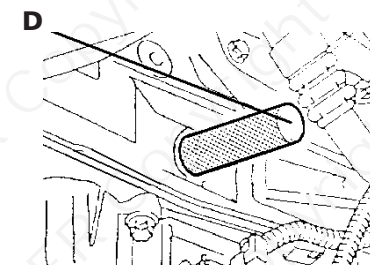
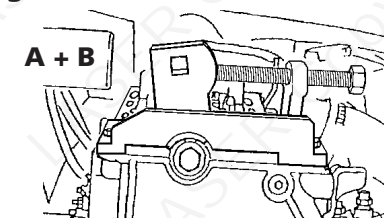

Fig. 4



## Instruction (ES)

La posición correcta se consigue cuando el primer cilindro está a su punto muerto superior y cada una de las herramientas se pueden montar correctamente.

1. El árbol de levas se posiciona horizontalmente con el agujero de locación arriba. Use la placa (E) para alinear el árbol de levas.
2. El pasador de la bomba (C) se alinea con una señal de calado en el piñón y se coloca dentro del agujero de retención. Ver fig. 2.
3. El pasador de cigüeñal (D) se usa para posicionar el cigüeñal a su punto muerto superior. Se coloca en una ranura del cigüeñal a través del bloque del motor.
4. La llave (A) y util (B) facilita la posición correcta a través del piñón del árbol de levas y la cadena simplex. Primero coloque la llave (A) verticalmente al piñón y después el util (B) al cilindro. Utilizando una llave de carraca de 1/2" gire ligeramente el árbol de levas en sentido contrario a las agujas del reloj. Gire el tornillo para hacer contacto con la llave (A) y mantener esta posición. (ver fig.4).
5. El pasador (C) debe estar suelto. Si no se mueve con facilidad, ajuste el tornillo hasta que se mueva libremente. El piñón del árbol de levas se puede apretar y el tensor de la cadena simples remontado.

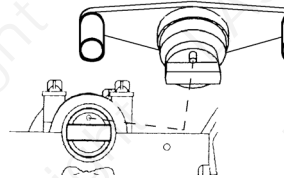
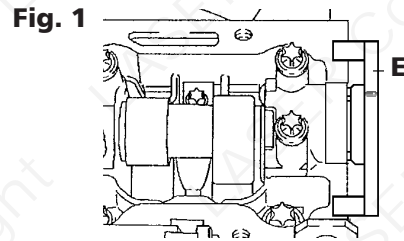

**Fig. 2**

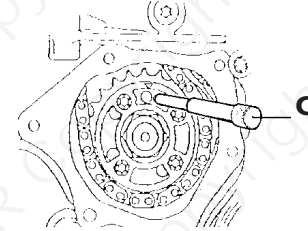

**Fig. 3**

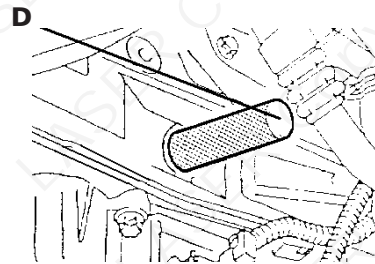

**Fig. 4**

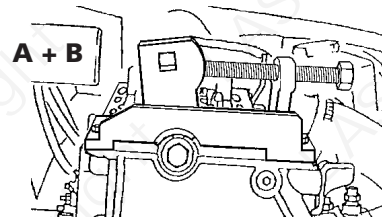

## Applications

The application list for this product has been compiled cross referencing the OEM Tool Code with the Component Code.

In most cases the tools are specific to this type of engine and are necessary for Cam belt or chain maintenance.

If the engine has been identified as an interference engine valve to piston damage will occur if the engine is run with a broken Cam belt.

A compression check of all cylinders should be performed before removing the cylinder head.

Always consult a suitable work shop manual before attempting to change the Cam belt or Chain.

The use of these engine timing tools is purely down to the user's discretion and Tool Connection cannot be held responsible for any damage caused what so ever.

ALWAYS USE A REPUTABLE WORKSHOP MANUAL

| Manufacturer    | Model      | Style           | Engine Code | Year    |
|-----------------|------------|-----------------|-------------|---------|
| Opel   Vauxhall | Astra-G    | 2.0   DTi   D   | X20DTL      | 1998-02 |
|                 |            |                 | Y20DTH      | 1999-05 |
|                 |            |                 | Y20DTL      | 2000-05 |
|                 |            |                 | Y22DTR      | 2000-06 |
| Opel   Vauxhall | Frontera-B | 2.2   DTi   D   | X22DTH      | 1998-01 |
|                 |            |                 | Y22DTH      | 2000-04 |
| Opel   Vauxhall | Omega-B    | 2.0   DTi   D   | X20DTH      | 1998-00 |
|                 |            |                 | Y22DTH      | 2000-03 |
| Opel   Vauxhall | Signum     | 2.0   DTi   D   | Y20DTH      | 2003-05 |
|                 |            |                 | Y22DTR      | 2003-05 |
| Opel   Vauxhall | Sintra     | 2.2   Turbo   D | X22DTH      | 1998-99 |
| Opel   Vauxhall | Vectra-B   | 2.0   DTi   D   | X20DTH      | 1997-00 |
|                 |            |                 | X20DTL      | 2000-00 |
|                 |            |                 | Y20DTH      | 2000-02 |
| Opel   Vauxhall | Vectra-B   | 2.2   DTi   D   | Y22DTR      | 2000-02 |
| Opel   Vauxhall | Vectra-C   | 2.0   DTi   D   | Y20DTH      | 2002-05 |
|                 |            |                 | DTi   D     | Y22DTR  |
| Opel   Vauxhall | Zafira-A   | 2.0   DTi   D   | X20DTL      | 1999-00 |
|                 |            |                 | DTi   D     | Y20DTH  |
| Opel   Vauxhall | Zafira-A   | 2.2   DTi   D   | Y22DTR      | 2002-05 |
| Saab            | 9-3        | 2.2   DTi   D   | D223L       | 1998-06 |

## Instruction (GB)

The correct engine timing position is achieved when the first cylinder is at TDC and each of the timing tools can be correctly fitted.

1. The camshaft is positioned horizontally with the location hole at the top. Use the camshaft setting tool **(E)** to align the camshaft (see Fig.1)
2. The Injection Pump Setting Pin **(C)** aligns to a timing mark on the sprocket and is fitted through a recess in the injection pump flange and into the retaining hole. (see Fig.2)
3. The crankshaft locking pin **(D)** is used to set the crankshaft at TDC position. This tool is fitted through the crankshaft pulse pick-up opening in the engine block and locates into a slot in the crankshaft. (see Fig.3)
4. Fuel Pump Sprocket Timing Tool **(A+B)** enables the correct timing position through action to the simplex chain and camshaft sprocket. First attach the special wrench vertically to the sprocket, then attach the bracket assembly to the cylinder head. Using a  $\frac{1}{2}$ " Sq. Dr. wrench to apply light pressure to turn the camshaft in an anti-clockwise (contra-engine rotation). The screw is the turned to contact the special wrench and retain this position. (see Fig.4)
5. At this stage the Pump Locking Pin **(C)** should be free to be removed and re-fitted. If this pin is tight, adjust the screw until the pin is easy to move. The camshaft sprocket bolt can now be tightened and refit the simplex chain tensioner.

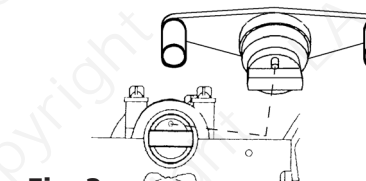
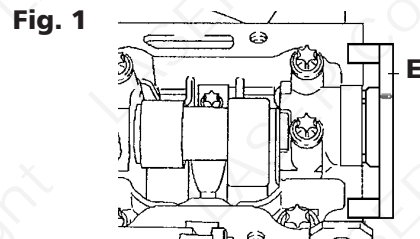

Fig. 2

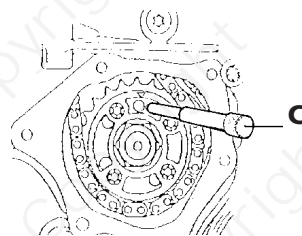

Fig. 3

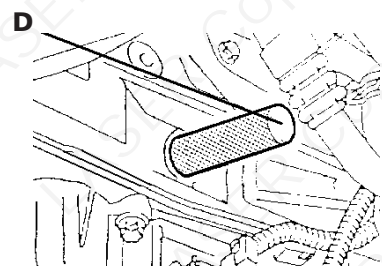
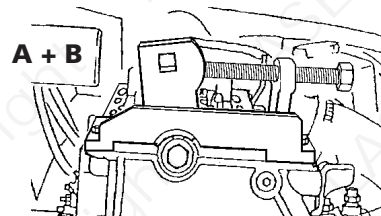

Fig. 4



## Instruction (FR)

La position de calage correcte du moteur est obtenue lorsque le premier cylindre est au PMH et que chacun des outils de calage peut être installé correctement.

1. L'arbre à cames est positionné horizontalement avec l'orifice de positionnement sur le haut. Utiliser l'outil de blocage de l'arbre à cames (E) pour aligner l'arbre à cames (voir la Fig.1)
2. La cheville de réglage de la pompe à injection (C) s'aligne sur un repère de calage de la roue dentée et elle est insérée à travers un logement de la bride de la pompe à injection et dans l'orifice de fixation. (voir la Fig.2)
3. La cheville de blocage du vilebrequin (D) est utilisée pour bloquer le vilebrequin dans la position PMH. Cet outil est installé à travers l'ouverture du capteur d'impulsions du vilebrequin dans le bloc moteur et il s'insère dans une encoche du vilebrequin. (voir la Fig.3)
4. L'outil de calage de la roue dentée de la pompe à carburant (A+B) permet d'obtenir la position de calage correcte par action sur la chaîne simplex et la roue dentée de l'arbre à cames. Poser d'abord verticalement la clé spéciale sur la roue dentée, puis poser l'ensemble support sur la culasse. A l'aide d'une clé à carré conducteur de  $\frac{1}{2}$ " , exercer une légère pression pour faire tourner l'arbre à cames dans le sens anti-horaire (sens inverse à celui de la rotation du moteur). La vis tourne jusqu'en butée avec la clé spéciale et elle reste dans cette position. (voir la Fig.4)  
À ce moment-là, la cheville de blocage de la pompe (C) peut être déposée et réinstallée librement. Si cette cheville est serrée, ajuster la vis jusqu'à ce que la cheville puisse bouger facilement. Le boulon de la roue dentée d'arbre à cames peut maintenant être serré et le tendeur de la chaîne simplex réinstallé

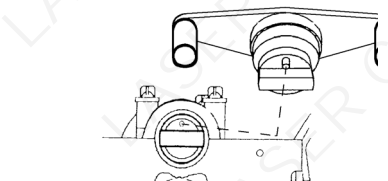
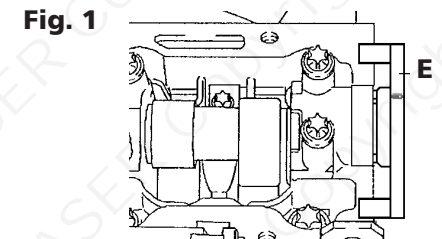

Fig. 2

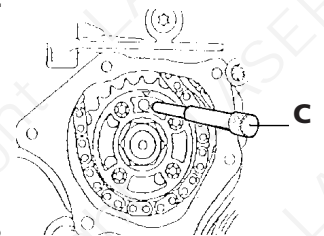

Fig. 3

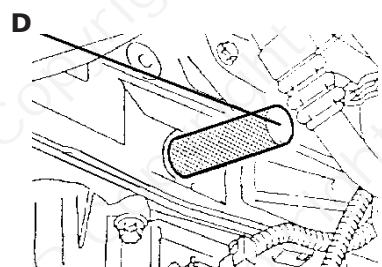

Fig. 4

