

Charlize®



WOOD RACK

MODEL NO: CWRT

PART NO: 3402060

ASSEMBLY INSTRUCTIONS

INTRODUCTION

Thank you for purchasing this Wood Rack.

Please read this manual thoroughly, and carefully follow all instructions.

GUARANTEE

This CLARKE product is guaranteed against faulty manufacture for a period of 12 months from the date of purchase. Please keep your receipt as proof of purchase.

This guarantee is invalid if the product is found to have been abused or tampered with in any way, or not used for the purpose for which it was intended.







Faulty goods should be returned to their place of purchase, no product can be returned to us without prior permission.

This guarantee does not effect your statutory rights.

SPECIFICATIONS

Maximum Load	100 kg
Dimensions W x H x D	1330 x 1300 x 295 mm

PARTS

 Side Rails x 2	 Front Rails x 2
 Connecting Strip x 2	 M8 x 75 Bolts x 8
 Washers x 8	 M8 Nut x 8

ASSEMBLY

1. Stand one of the side rails up and place the two front rails in position as shown.

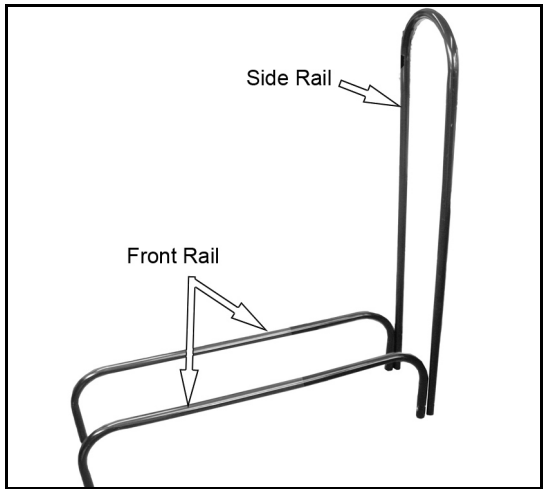

2. Pass a bolt through each end of the connecting strip then through the higher of the two holes in the side rail and front rail as shown.

- Secure the bolt in place using a washer and nut supplied.

3. Pass a bolt through the lower of the two holes in the side rail and front rail as shown.

4. Position the second side rail at the other end of the front rails and repeat steps 2 and 3 for this end of the wood rack.

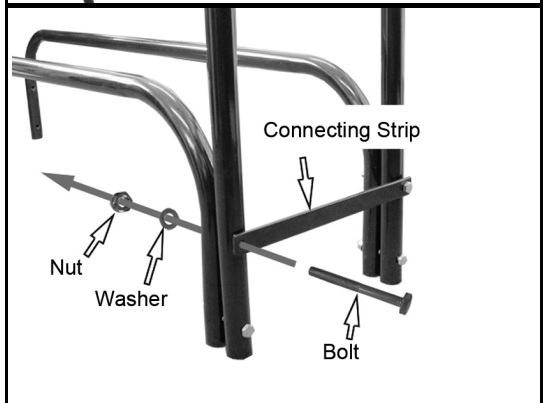

WARNINGS

- Do not overload the wood rack (Maximum 100 kg).
- Make sure all bolts are secure before using the wood rack.
- Do not use the wood rack to lift yourself up.

A SELECTION FROM THE VAST RANGE OF

Clarke®

QUALITY PRODUCTS

AIR COMPRESSORS

From DIY to industrial, Plus air tools, spray guns and accessories.

GENERATORS

Prime duty or emergency standby for business, home and leisure.

POWER WASHERS

Hot and cold, electric and engine driven - we have what you need

WELDERS

Mig, Arc, Tig and Spot. From DIY to auto/industrial.

METALWORKING

Drills, grinders and saws for DIY and professional use.

WOODWORKING

Saws, sanders, lathes, mortisers and dust extraction.

HYDRAULICS

Cranes, body repair kits, transmission jacks for all types of workshop use.

WATER PUMPS

Submersible, electric and engine driven for DIY, agriculture and industry.

POWER TOOLS

Angle grinders, cordless drill sets, saws and sanders.

STARTERS/CHARGERS

All sizes for car and commercial use.

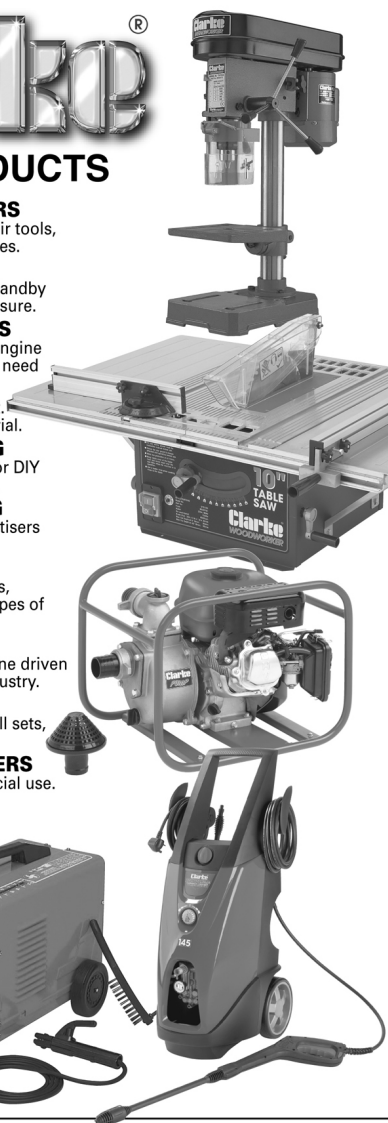

PARTS & SERVICE: 0208 988 7400

E-mail: Parts@clarkeinternational.com or Service@clarkeinternational.com

SALES: UK 01992 565333 or Export 00 44 (0)1992 565335

Clarke® INTERNATIONAL Hemnall Street, Epping, Essex CM16 4LG
www.clarkeinternational.com