



Please dispose of packaging for the product in a responsible manner. It is suitable for recycling. Help to protect the environment, take the packaging to the local amenity tip and place into the appropriate recycling bin.



Never dispose of electrical equipment or batteries in with your domestic waste. If your supplier offers a disposal facility please use it or alternatively use a recognised re-cycling agent. This will allow the recycling of raw materials and help protect the environment.



SIP INDUSTRIAL

machinery specialists since 1968

12v / 24v Diesel Transfer Pump Kit



06801 / 06803

**FOR HELP OR ADVICE ON THIS PRODUCT PLEASE CONTACT YOUR DISTRIBUTOR, OR
SIP DIRECTLY ON:
TEL: 01509500400
EMAIL: sales@sip-group.com or technical@sip-group.com
www.sip-group.com**

**Please read and fully understand the instructions in this manual
before operation. Keep this manual safe for future reference.**

Declaration of Conformity

We

SIP (Industrial Products) Ltd
Gelders Hall Road
Shepshed
Loughborough
Leicestershire
LE12 9NH
England

As the manufacturer's authorised representative within the EC
declare that the

12v Diesel Transfer pump - SIP Part No. 06801
24v Diesel Transfer Pump - SIP Part No. 06803

Conforms to the requirements of the following directive(s), as indicated.

2014/30/EU	EMC Directive
2011/65/EU	RoHS Directive

And the relevant harmonised standard(s), including

EN 61000-6-1:2007
EN 61000-6-3:2007+A1:2011

Signed: 

Mr P. Ippaso - Managing Director - SIP (Industrial Products) Ltd
Date: 17/09/2014.



Page No.	Description
4.	Safety Symbols Used Throughout This Manual
4.	Safety Instructions
9.	Electrical Connection
10.	Guarantee
11.	Contents and Accessories
12.	Technical Specification
13.	Assembly Instructions
17.	Operating Instructions
19.	Maintenance
20.	Wiring Diagram
21.	Exploded Drawing
22.	Parts List
27.	Declaration of Conformity

SAFETY SYMBOLS USED THROUGHOUT THIS MANUAL



Danger / Caution: Indicates risk of personal injury and/or the possibility of damage.



Warning: Risk of electrical injury or damage!



Note: Supplementary information.

SAFETY INSTRUCTIONS



Important: Please read the following instructions carefully, *failure to do so could lead to serious personal injury and / or damage to the transfer pump.*

When using your transfer pump, basic safety precautions should always be followed to reduce the risk of personal injury and / or damage to the pump.

Read all of these instructions before operating the pump and save this user manual for future reference.

The pump should **not** be modified or used for any application other than that for which it was designed.

The diesel transfer pump is designed for the delivery of diesel fuel, with a viscosity from 2 to 5.35 cSt (at a temperature of 38.7°C) and a flash point >55°C, to vehicles and equipment from a suitable storage tank. The pump is a self priming, positive displacement, rotary vane machine which operates on a 12V DC (06801) supply or 24V DC (06803) supply. They deliver a flow of approximately 45 litres per minute (Max.). The pump has a built-in bypass valve for added safety and the motor has a 30 minute duty cycle.

If you are unsure of its relative applications do not hesitate to contact us and we will be more than happy to advise you.

Before each use of the pump always check no parts are broken and that no parts are missing.

Always operate the pump safely and correctly.

KNOW YOUR TRANSFER PUMP: Read and understand the owner's manual and labels affixed to the pump. Learn its applications and limitations, as well as the potential hazards specific to it.

KEEP WORK AREA CLEAN AND WELL LIT: Cluttered work benches and dark areas invite

NOTES

accidents. Floors must not be slippery due to fuel, oil, water or sawdust etc.

KEEP CHILDREN AND UNTRAINED PERSONNEL AWAY FROM THE WORK AREA: All visitors should be kept at a safe distance from the work area.

STORE THE PUMP SAFELY WHEN NOT IN USE: The pump should be stored in a dry location and disconnected from the power supply, and out of the reach of children.

STAY ALERT: Always watch what you are doing and use common sense. Do not operate the pump when you are tired or under the influence of alcohol or drugs.

DISCONNECT THE PUMP FROM THE POWER SUPPLY: When not in use and before servicing.

NEVER LEAVE THE PUMP RUNNING WHILST UNATTENDED: Turn the pump off and disconnect it from the power supply between jobs.

DO NOT ABUSE THE BATTERY / POWER LEADS: Never attempt to move the pump by the supply leads or pull them to remove the clips from the power supply. Keep the leads away from heat, oil, sharp edges and moving parts. If the power supply lead is damaged, it must be replaced by the manufacturer or its service agent or a similarly qualified person in order to avoid unwanted hazards.

CHECK FOR DAMAGED PARTS: Before every use of the pump, any damage found should be carefully checked to determine that it will operate correctly, safely and perform its intended function. Any damaged, split or missing parts that may affect its operation should be correctly repaired or replaced by an authorised service centre unless otherwise indicated in this instruction manual.

KEEP ALL COVERS / PANELS IN PLACE: Never operate the pump with any covers removed, this is extremely dangerous.

USE ONLY RECOMMENDED ACCESSORIES: Consult this user manual, your distributor or SIP directly for recommended accessories. Follow the instructions that accompany the accessories. The use of improper accessories may cause hazards and will invalidate any warranty you may have.

DO NOT OVERREACH: Keep proper footing and balance at all times.

USE THE RIGHT TOOL: Do not use the pump to do a job for which it was not designed.

DO NOT OPERATE THE PUMP IN EXPLOSIVE ATMOSPHERES: Do not use the pump in the presence of flammable liquids with a flash point below 55°C, gases, dust or other combustible sources.

HAVE YOUR PUMP REPAIRED BY A QUALIFIED PERSON: The pump is in accordance with the relevant safety requirements. Repairs should only be carried out by qualified persons using original spare parts, otherwise this may result in considerable danger to the user.

- Stop operation immediately if you notice anything abnormal.
- Be alert at all times, especially during repetitive, monotonous operations; Don't be lulled into a false sense of security.
- Use of improper accessories may cause damage to the pump and surrounding area as well as increasing the risk of injury.
- **Do not** modify the pump to do tasks other than those intended.
- **Do not** attempt any repairs unless you are a competent electrician or engineer.

SAFETY INSTRUCTIONS....cont

- Ensure that the pump is connected to the correct supply voltage.
- Become familiar with the controls before operating this pump.
- Do not attempt to move the pump when it is loaded and/or in operation.
- Check all bolts, nuts, pipe fittings and screws etc. before each use.
- When maintaining this pump, only the manufacturer's original replacement parts may be used.
- Do not operate the pump with wet hands.
- Ensure that the operator has read and understands the material safety data sheet (MSDS) for the type of fuel being pumped and that all cautions are adhered to.
- Always operate the pump in a well ventilated area to reduce fume build up.
- Ensure that the battery is as far away as possible from the pump when connecting the power supply leads.
- Do not turn the pump on / off by connecting / disconnecting the supply leads; Always use the switch on the pump.
- Ensure that the switch is in the off position before connecting the power supply leads.
- Never operate the pump for longer than its duty cycle (30 minutes); Allow the pump to cool for 30 minutes if the pump has been run for the length of its duty cycle.
- Never smoke whilst operating the pump.
- Never place the pump where open flames are present.
- Never operate the pump 'dry' with no fuel running through it; This will damage the internal components of the pump and invalidate your warranty.
- Never operate the pump for more than 2-3 minutes in 'by-pass' mode (with the supply nozzle closed).
- Appropriate personal protective equipment, clothing, gloves and safety glasses etc. **must** be worn and **must** be de-signed to protect against all hazards created. Severe permanent injury can result from using inappropriate or insufficient protective equipment.



Always wear suitable eye protection when using or maintaining the transfer pump.

NOTES

TROUBLESHOOTING

Pump won't prime.	suction line problem.	Check for leaks or obstruction in suction hose or pipe.
	Outlet is blocked.	Check to make sure outlet hose and nozzle are clear and operating correctly.
	Inlet is blocked	Check to make sure inlet hose and filter are clear.
	Debris in Bypass valve.	Inspect / have the bypass valve inspected.
	Motor vanes are sticking	Inspect / have the vanes and slots in rotor inspected for nicks or burrs.
	Excessive rotor and/or vane wear.	Check and replace / have the rotor and vanes replaced.
	Suction head too high.	Lower the pump in relation to the storage tank.
Motor is not turning	Lack of electric power.	Check electrical connections and battery.
	Rotor jammed.	Have checked / check the rotating parts of the motor for obstructions.
	Motor issues.	Contact service centre.
	Input fuse Blown.	Replace fuse.
Motor turns slowly	Low voltage in power line.	Ensure the voltage of the power supply is within acceptable levels.
Low Flow Rate	Blocked Filter.	Clean Or replace the filter.
	Rotor or vanes damaged / worn.	Replace worn parts.
	Suction head too high.	Lower the pump in relation to the storage tank.
	Air entering the system.	Check seal and connections etc.
	Low rotation speed.	Check electrical connections and battery.
Motor surface temperature gets hotter than 100°C (212°F).	Fluid is too thick.	Fluid must not be thicker than diesel fuel.
Pump will not operate	Duty cycle exceeded.	The pump is designed to run for 30 mins. Max. allow the pump to cool for at least 30 mins.
	Fuse Blown.	Replace fuse and investigate why the fuse has blown.
	Faulty Switch.	Replace switch.
	Power supply is dead.	Check power supply voltage.

ELECTRICAL CONNECTION

Warning! It is the responsibility of the owner and the operator to read, understand and comply with the following:

You must check all electrical products, before use, to ensure that they are safe. You must inspect power cables, plugs, sockets and any other connectors for wear or damage.

Connecting to the power supply:

These Diesel transfer pumps have an input voltage of 12V DC (06801) & 24V DC (06803) supply and are IP55 rated.

1. Connect the battery clips on the motor power cable to a suitable battery, capable of delivering the necessary voltage and current.
 - The **RED** clip is attached to the positive (+) battery terminal.
 - The **BLACK** clip is attached to the negative (-) battery terminal or to the vehicle frame.



Warning: Never connect the black lead to the positive terminal or the red lead to the negative terminal.



Danger: Avoid sparks that could cause a fire.



Danger: Do not use an extension lead to extend the power cables.

GUARANTEE

These SIP transfer pumps are covered by a 12 month parts and labour warranty covering failure due to manufacturers defects. This does not cover failure due to misuse or operating the pump outside the scope of this manual - any claims deemed to be outside the scope of the warranty may be subject to charges including, but not limited to parts, labour and carriage costs, failure to regularly clean your pump will shorten its working life and reduce performance.

Consumable items such as fuses, motor vanes and filters are not covered by the warranty.



Note: Proof of purchase will be required before any warranty can be honoured.

CONTENTS AND ACCESSORIES

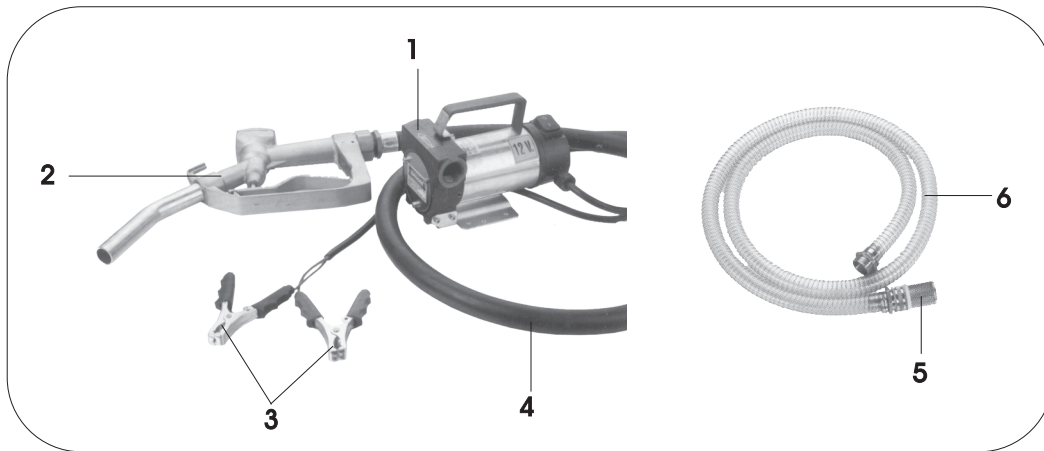

- 1. Diesel Transfer Pump.
- 2. Delivery Gun/Pistol.
- 3. Power Supply Lead (connected to pump).
- 4. 4m Delivery Hose.
- 5. Inlet Filter.
- 6. 2m Suction Hose.
- Instruction Manual (not pictured).



Note: If any of the above are missing or damaged, contact your distributor immediately.

PARTS LIST - 06801

Ref. No.	Description	Sip Part No.	Ref. No.	Description	Sip Part No.
1.	Motor 24v	PW11-00150	11.	Bypass valve	PW11-00140
2.	Rear cover kit 24v	PW11-00151	12.	Bypass spring	PW11-00141
3.	Seal kit	PW11-00132	13.	O-ring	PW11-00142
4.	Brush cover	PW11-00133	14.	Handle screw M5x8	PW11-00143
5.	Switch	PW11-00134	15.	O-ring	PW11-00144
6.	Key	PW11-00135	16.	Front cover	PW11-00145
7.	Compensating ring	PW11-00136	17.	Base	PW11-00146
8.	Pump body	PW11-00137	18.	Fuse holder	PW11-00147
9.	Rotor	PW11-00138	19.	Fuse	PW11-00152
10.	Blade	PW11-00139	20.	Handle	PW11-00149

EXPLODED DRAWING - 06803

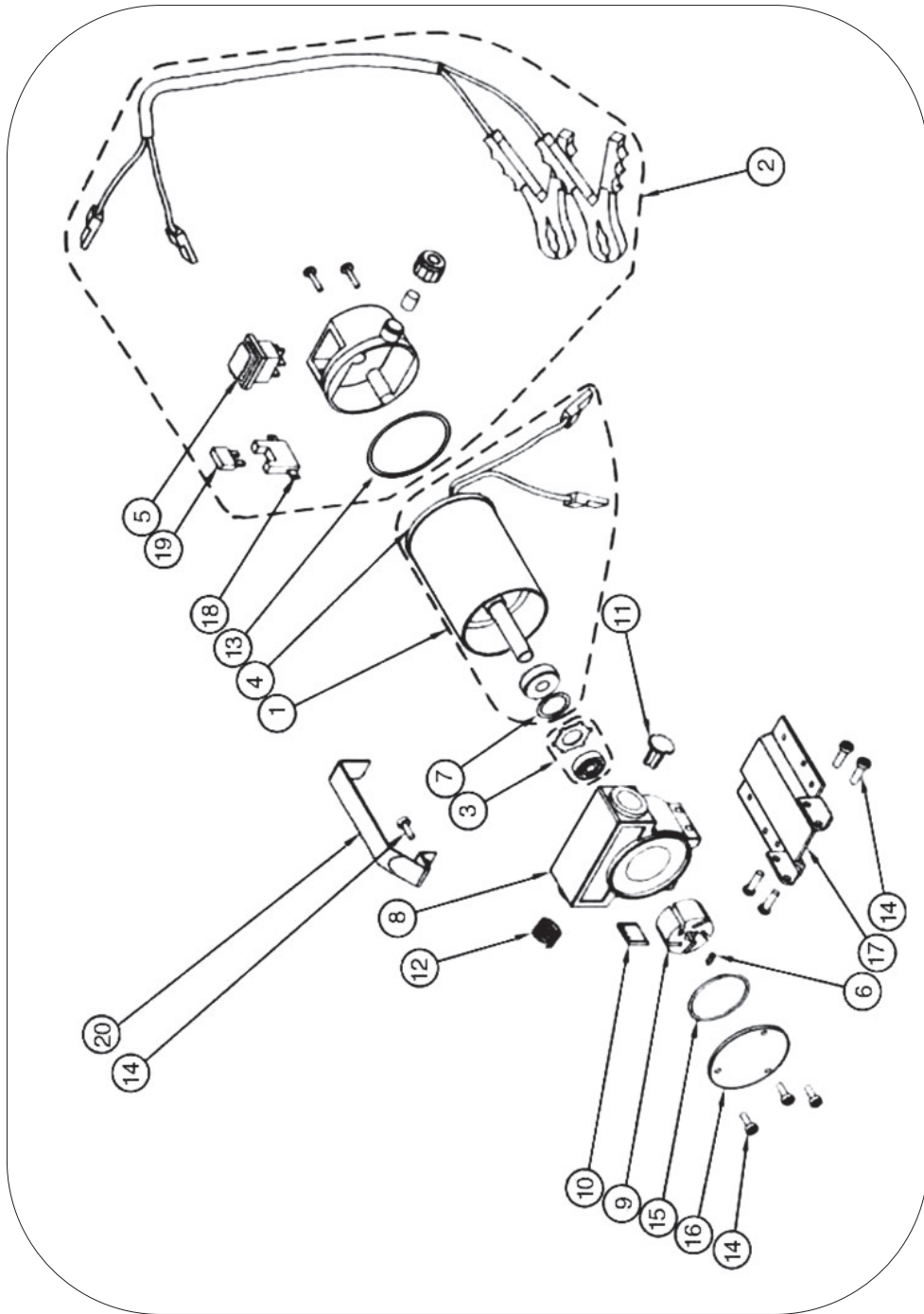

GETTING TO KNOW YOUR TRANSFER PUMP

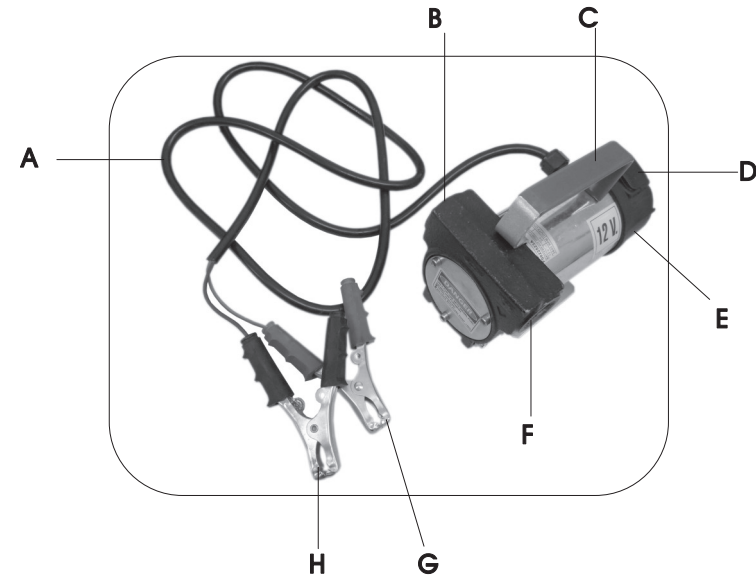

Ref.	Description	Ref.	Description
A.	Power Lead	E.	Fuse Cover
B.	Fuel Outlet	F.	Fuel Inlet
C.	Handle	G.	Positive Clamp (Red)
D.	On/Off Switch	H.	Negative Clamp (Black)

TECHNICAL SPECIFICATION

Model No.	06801	06803
Input Voltage	12v DC	24v DC
Motor	140 watts	140 watts
Duty Cycle	30 mins (max.)	30 mins (max.)
Flow Rate	40 l/min (max.)	40 l/min (max.)
Protection	IP55	IP55
Net Weight		

ASSEMBLY INSTRUCTIONS

FITTING THE HOSES

To fit the delivery hose to the pump:

- Ensure that the supplied O-rings are fitted to each end of the hose (Fig. 1).
- Locate the pump outlet (Fig. 2).
- Screw the end of the hose with the smaller fitting into the pump outlet and tighten to secure (Fig. 3).
- Fit the delivery gun / pistol to the larger fitting on the opposite end of the hose and tighten to secure.

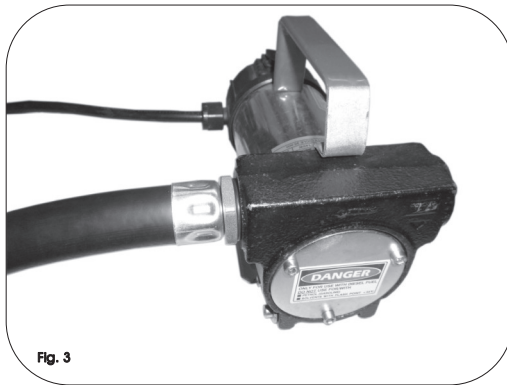
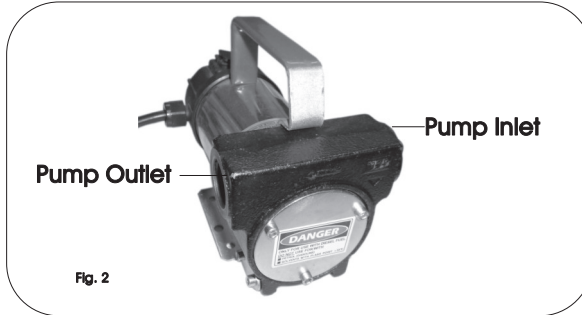
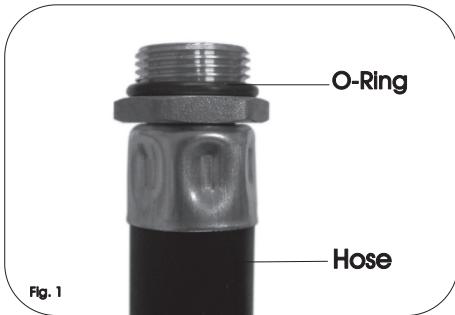

To fit the suction hose to the pump:

- Ensure that the supplied O-rings are fitted to each end of the hose.
- Screw the suction hose into the pump inlet and tighten to secure.
- Fit the inlet filter to the opposite end of the hose and tighten to secure.

PARTS LIST - 06801

Ref. No.	Description	Sip Part No.	Ref. No.	Description	Sip Part No.
1.	Motor 12v	PW11-00130	11.	Bypass valve	PW11-00140
2.	Rear cover kit	PW11-00131	12.	Bypass spring	PW11-00141
3.	Seal kit	PW11-00132	13.	O-ring	PW11-00142
4.	Brush cover	PW11-00133	14.	Handle screw M5x8	PW11-00143
5.	Switch	PW11-00134	15.	O-ring	PW11-00144
6.	Key	PW11-00135	16.	Front cover	PW11-00145
7.	Compensating ring	PW11-00136	17.	Base	PW11-00146
8.	Pump body	PW11-00137	18.	Fuse holder	PW11-00147
9.	Rotor	PW11-00138	19.	Fuse	PW11-00148
10.	Rotor blade	PW11-00139	20.	Handle	PW11-00149

EXPLODED DRAWING - 06801

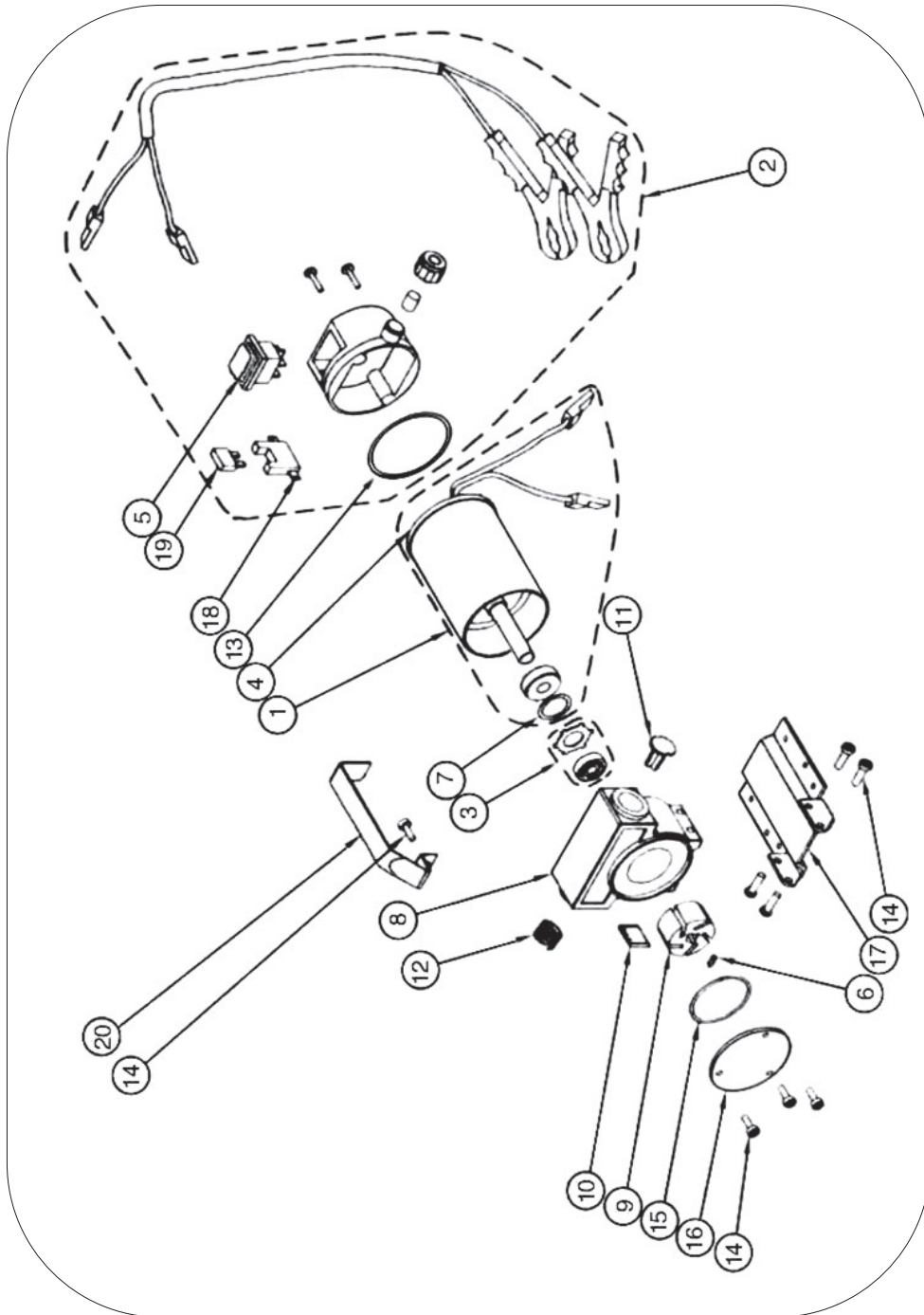

OPERATING INSTRUCTIONS

POSITIONING THE PUMP

The pump can be installed in any direction - Pump axis vertical or horizontal. The pump base should be fixed to a secure surface using the holes provided (Fig. 4).

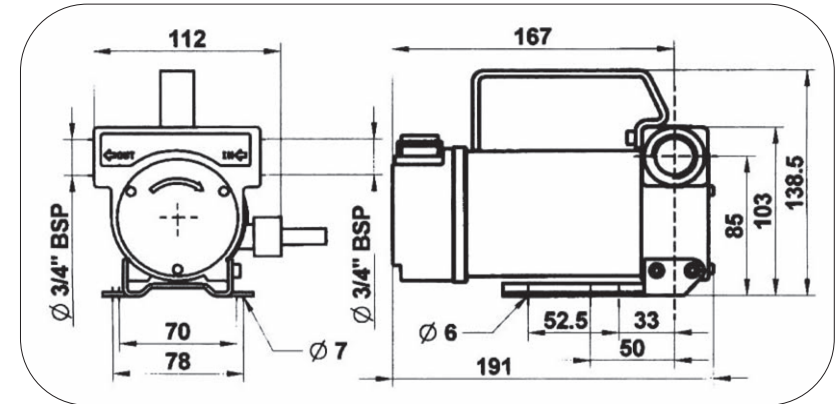

The pump should be installed so that the suction height is as low as possible - maximum of 2 metres.



Note: If the delivery tank is higher than the pump it may be necessary to fit an anti siphon valve to prevent any fuel loss / leaks.

Place the suction hose into the fuel tank so that the filter sits well below the fuel level.



Note: Never operate the pump without the inlet filter fitted.

OPERATING THE PUMP

Ensure all pipes etc. are fitted as described, and the suction hose (with filter) is correctly positioned in the fuel tank.

Connect the power input leads as described on page 7.

Insert the delivery nozzle into the container to be filled.

Switch the motor on.

Operate the nozzle lever to dispense fluid.



Note: Depending on the height of fuel / length of hoses etc. The pump will need to prime before the fuel will be pumped.

OPERATING INSTRUCTIONS...cont

When the desired amount of fluid has been dispensed, release nozzle lever to stop flow.

Immediately switch motor off.



Caution: Never run the pump in bypass mode (with the delivery nozzle closed) for more than 1 minute.



Caution: Never run the pump for more than 30 minutes maximum, and allow the pump to cool for at least 30 minutes.

MAINTENANCE



Caution: Ensure that the pump is turned off and that the clips are removed from the power supply before carrying out any cleaning or maintenance.

Other than keeping the pump clean, there is very little maintenance required.

- Inspect and clean the inlet filter on the inlet hose at least monthly.
- Clean the metal "mouth" portion of the battery clips with steel wool monthly to maintain good electrical connection to the battery.
- Check the power cables and clips for any damage before each use; repair or replace as necessary.
- Hoses and fittings should be inspected before each use and replaced / repaired if cracked / worn or leaking.
- Rotor and vanes will eventually wear, and should be replaced if pump performance degrades. See the "Operational Problems" section to determine if replacement is needed.
- Drain hoses and pump and store in a clean, dry place when not in use.