

A SELECTION FROM THE VAST RANGE OF

# Clarke®

QUALITY PRODUCTS

**AIR COMPRESSORS**

*From DIY to industrial. Plus air tools, spray guns and accessories.*

**GENERATORS**

*Prime duty or emergency standby for business, home and leisure.*

**POWER WASHERS**

*Hot and cold, electric and engine driven - we have what you need.*

**WELDERS**

*Mig, Arc, Tig and Spot. From DIY to auto/industrial.*

**METALWORKING**

*Drills, grinders and saws for DIY and professional use.*

**WOODWORKING**

*Saws, sanders, lathes, mortisers and dust extraction.*

**HYDRAULICS**

*Cranes, body repair kits, transmission jacks for all types of workshop use.*

**WATER PUMPS**

*Submersible, electric and engine driven for DIY, agriculture and industry.*

**POWER TOOLS**

*Angle grinders, cordless drill sets, saws and sanders.*

**STARTER/CHARGERS**

*All sizes for car & commercial use.*



**Clarke** INTERNATIONAL

For spare parts and servicing, please contact your nearest dealer, or Clarke International on

**020 - 8988 - 7400**

e-mail: [Parts@clarkeinternational.com](mailto:Parts@clarkeinternational.com) e-mail: [Service@clarkeinternational.com](mailto:Service@clarkeinternational.com)

# Clarke® WOODWORKER

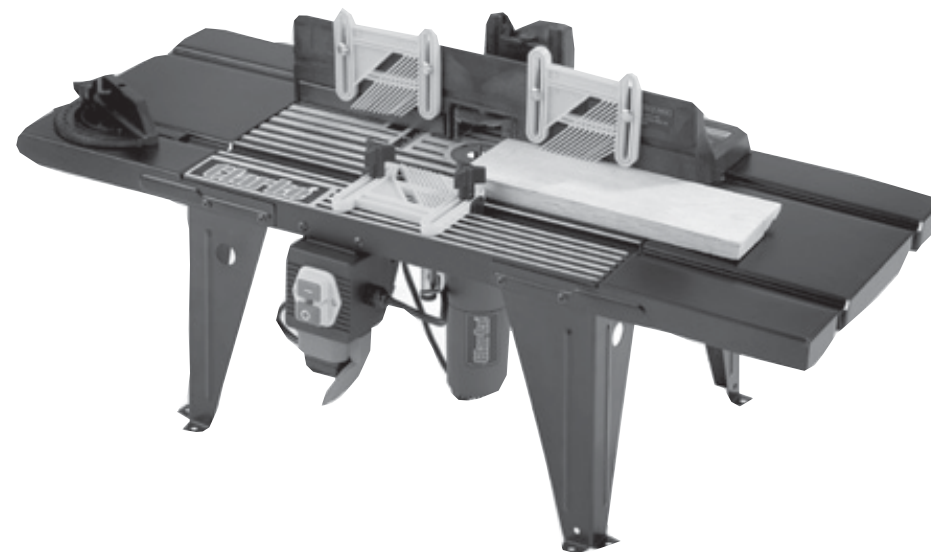

## ROUTER TABLE

MODEL NO: CRT 1

PART No: 6462115

## OPERATION & MAINTENANCE INSTRUCTIONS



## Contents

Page

Introduction .....	2
Guarantee .....	2
Specifications .....	2
Check List .....	2
Safety Precautions .....	3
Electrical Connection .....	4
Assembly .....	5, 6, & 7
Mounting The Router .....	7 & 8
Operation .....	8, 9 & 10
Height Adjustment .....	11, 12, & 13
Parts List .....	15
Parts Diagram .....	16
Declaration of Conformity .....	18

# Clarke<sup>®</sup>

## INTERNATIONAL

This is an important document and should be retained

## DECLARATION OF CONFORMITY



We declare that this product complies with the following standards/directives:

- 72/23/EEC
- 93/68/EEC
- 89/336/EEC

Description: Router Table

Model No: CRT1

Serial (Batch) No: See Data Plate

Signed: 

**Clarke<sup>®</sup>** INTERNATIONAL  
Hemnal Street, Epping, Essex CM16 4LG

DOC No. HO75/27

Clarke International is a trading style of Clarke International Limited

Thank you for purchasing this CLARKE Router table designed for DIY use only. Before attempting to use the table, please read this manual thoroughly and follow the instructions carefully. In doing so you will ensure the safety of yourself and that of others around you, and you can look forward to the equipment giving you long and satisfactory service.

## CLARKE GUARANTEE

This CLARKE product is guaranteed against faulty manufacture for a period of 12 months from the date of purchase. Please keep your receipt as proof of purchase.

This guarantee is invalid if the product is found to have been abused or tampered with in any way, or not used for the purpose for which it was intended.

Faulty goods should be returned to their place of purchase, no product can be returned to us without prior permission.

This guarantee does not effect your statutory rights.

## 1. Specifications

Model No: ..... CRT 1

Part No: ..... 6462115

Dimensions LxWxH: ..... 865x375x390mm

Weight: ..... 7Kg

Please note that the details and specifications contained herein, are correct at the time of going to print. However, CLARKE International reserve the right to change specifications at any time without prior notice.

## 2. Check List

Instruction Manual (Not Shown)

1. Table Top, 1 off.
2. Table Extension, 2 off.
3. Table Leg , 4 off.
4. Fence Profile, 1 off.
5. Fence Pressure Pad (feather board) including fittings, 2 off.
6. Table Pressure Pad (feather board) including fittings, 1 off.
7. Switch Assembly, 1 off.
8. Vacuum Hose Adapter, 1 off.
9. Clamp, 4 off.
10. Plastic Bag containing screws and fittings.
11. Mitre Gauge.

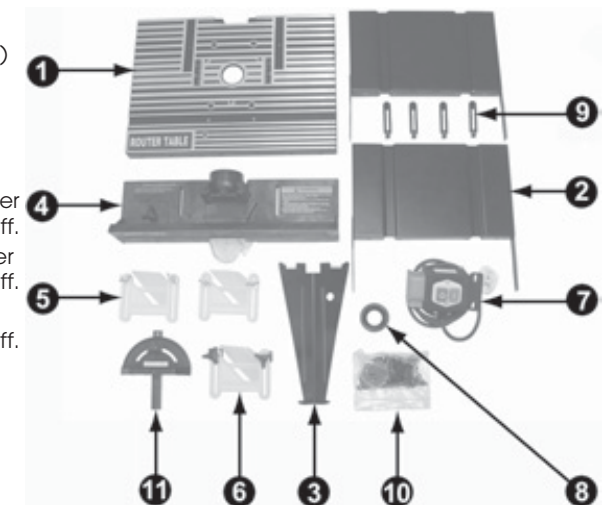



### 3. Safety Precautions



**WARNING:**

As with all machinery, there are certain hazards involved with their operation and use. Exercising respect and caution will considerably lessen the risk of personal injury. However, if normal safety precautions are overlooked or ignored, personal injury to the operator or damage to property, may result.

1. **ALWAYS** Learn the machines applications, limitations and the specific potential hazards peculiar to it. Read and become familiar with the entire operating manual.
2. **ALWAYS** use a face or dust mask if operation is particularly dusty.
3. **ALWAYS** check for damage. Before using the machine, any damaged part, should be checked to ensure that it will operate properly, and perform its intended function. Check for alignment of moving parts, breakage of parts, mountings, and any other condition that may affect the machines operation. Any damage should be properly repaired or the part replaced. If in doubt, **DO NOT** use the machine. Consult your local dealer.
4. **ALWAYS** disconnect the tool/machine from the power supply before servicing and when changing accessories.
5. **ALWAYS** wear safety goggles, manufactured to the latest European Safety Standards. Everyday eyeglasses do not have impact resistant lenses, they are not safety glasses.
6. **ALWAYS** keep work area clean. Cluttered areas and benches invite accidents.
7. **ALWAYS** ensure that adequate lighting is available. A minimum intensity of 300 lux should be provided. Ensure that lighting is placed so that you will not be working in your own shadow.
8. **ALWAYS** keep children away. All visitors should be kept a safe distance from the work area, especially whilst operating the machine.
9. **ALWAYS** maintain machine in top condition. Keep tools/ machines clean for the best and safest performance. Follow maintenance instructions.
10. **ALWAYS** handle with extreme care do not carry the tool/machine by its' electric cable, or yank the cable to disconnect it from the power supply.
11. **ALWAYS** ensure the switch is off before plugging in to mains. Avoid accidental starting.
12. **ALWAYS** concentrate on the job in hand, no matter how trivial it may seem. Be aware that accidents are caused by carelessness due to familiarity.
13. **ALWAYS** keep your proper footing and balance at all times - don't overreach. For best footing, wear rubber soled footwear. Keep floor clear of oil, scrap wood etc.



### 9. Parts List

Item	Part No	Description	Qty
01	HTCRT1001	Table Top	1
02	HTCRT1002	Table Extension	2
03	HTCRT1003	Table Leg	4
04	HTCRT1004	Table Insert Ø38mm (1½")	1
05	HTCRT1005	Fence Profile	1
06	HTCRT1006	Adjustable Fence	1
07	HTCRT1007	Cutter Guard	1
08	HTCRT1008	Spring	1
09	HTCRT1009	Flat Washer	1
10	HTCRT1010	Screw	1
11	HTCRT1011	Knob	3
12	HTCRT1012	Vacuum Hose Adapter	1
13	HTCRT1013	Hexagon Head Bolt	1
14	HTCRT1014	Coach Bolt	4
15	HTCRT1015	Knob	1
16	HTCRT1016	Clamp	4
17	HTCRT1017	Nut	4
18	HTCRT1018	Switch Box Assembly	1
19	HTCRT1019	Phillips Head Machine Screw	16
20	HTCRT1020	Hexagon Lock Nut	16
21	HTCRT1021	Label	1
22	HTCRT1022	Mitre Bar	1
23	HTCRT1023	Mitre Gauge Head	1
24	HTCRT1024	Label	1
25	HTCRT1025	Table Insert Ø13mm (½") Not Shown	1
26	HTCRT1026	Table Insert Ø19mm (¾") Not Shown	1
27	HTCRT1027	Table Insert Ø25mm (1") Not Shown	1
28	HTCRT1028	Table Insert Ø32mm (1¼") Not Shown	1
29	HTCRT1029	Fence Feather Board, inc fittings (not shown)	2
30	HTCRT1030	Table Feather Board, inc fittings (not Shown)	1

**IMPORTANT:**

The use of parts other than CLARKE replacement parts may result in safety hazards, decreased tool performance and may invalidate your warranty.

## 8. Parts Diagram

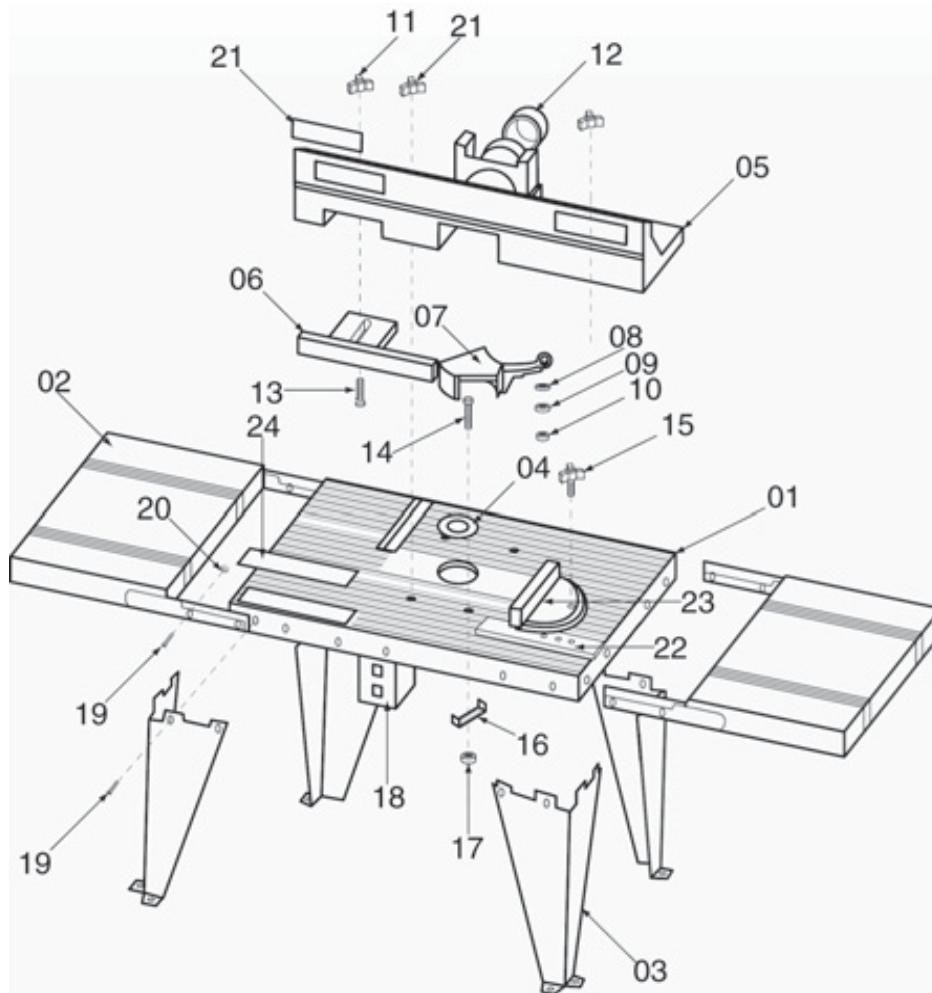

**PARTS & SERVICE TEL: 020 8988 7400**

**or e-mail as follows:**

**PARTS: Parts@clarkeinternational.com**

**SERVICE: Service@clarkeinternational.com**

## 4. Electrical Connections

This product is provided with a standard 13 amp, 230 volt (50Hz), BS 1363 plug, for connection to a standard, domestic electrical supply. Should the plug need changing at any time, ensure that a plug of identical specification is used.

**WARNING ! THIS APPLIANCE MUST BE EARTHED**

*This machine must be wired up in accordance with the following colour code:*

!	BLUE	-	NEUTRAL	!
	BROWN	-	LIVE	
	GREEN/YELLOW	-	EARTH	

- Connect the BLUE coloured cord to the plug terminal marked "N"
- Connect the BROWN coloured cord to the plug terminal marked "L"
- Connect the GREEN/YELLOW coloured cord to the plug terminal marked "E"

If this appliance is fitted with a plug which is moulded on to the electric cable (i.e. non-rewireable) please note:

1. The plug must be thrown away if it is cut from the electric cable. There is a danger of electric shock if it is subsequently inserted into a socket outlet.
2. Never use the plug without the fuse cover fitted.
3. Should you wish to replace a detachable fuse carrier, ensure that the correct replacement is used (as indicated by marking or colour code).
4. Replacement fuse covers can be obtained from your local dealer or most electrical stockists.



### Fuse Rating

The fuse in the plug must be replaced with one of the same rating (**13 amps**) and this replacement must be approved to BS1362.

If in doubt, consult a qualified electrician. Do not attempt any electrical repairs yourself.

### Cable Extension

Always use an approved cable extension suitable for the power rating of this tool (see specifications), the conductor size should also be at least the same size as that on the machine, or larger. When using a cable reel, always unwind the cable completely.

### IMPORTANT:

**If a cable extension is needed, it is essential to comply with the following data.**

Voltage	Extension length	Cable section
230v	Up to 20m	2.5mm <sup>2</sup>
230v	From 20 to 50m	4mm <sup>2</sup>

## 4. Assembly Item Nos in brackets, refer to check list on page 3

Before assembling the table, ensure all components are present, any shortages etc should be reported to the Clarke dealer where the table was purchased ASAP.

- 4.1 To assemble your router table, proceed as follows.
- 4.2 Lay the main table top (item 01) upside down on a flat surface, Fig. 1. Position one table top extension (Item 03) as in Fig. 2.

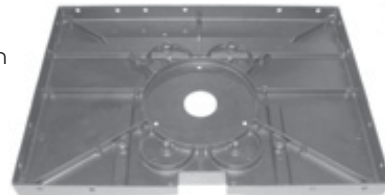

Fig. 1

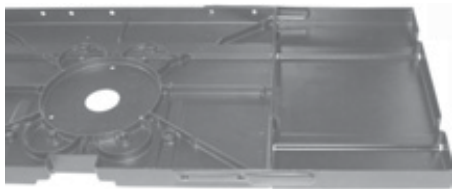

Fig. 2

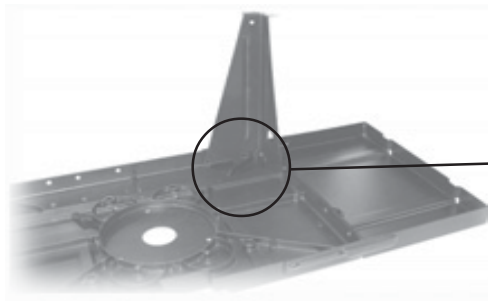
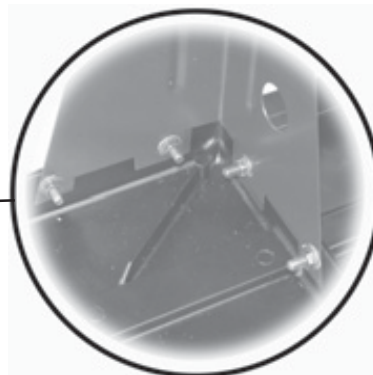

Fig. 3



- 4.3 Place table leg (Item 03) as shown in Fig. 3, loosely fix in position, using four screws and lock nuts, do not fully tighten yet.

**Note:** table leg fits inside the table profile, with fixing screws inserted from the outside with locknuts on the inside, see inset.

- 4.4 Repeat item 3 above for opposite table leg.
- 4.5 Once both table legs are loosely fitted, ensure the table and table extension are lying perfectly flat, gently tighten all screws, working from the centre to the outside, take care when tightening, not to move the extension table. DO NOT overtighten.
- 4.6 Repeat steps 1 to 5 for the other table extension and table legs. Once all four legs are securely tightened, turn assembly over, check the table assembly does not rock,

## PARTS LIST & DIAGRAM

Using 'G' clamps or similar, secure the bearer to the base board, taking care to ensure it doesn't move. Turn the assy over and drill the bearer through the holes in the baseboard using 6mm drill.

**IMPORTANT: before removing clamps, mark the bearer and baseboard position to ensure it is fitted in exactly the same position when assembling with the router table.**

Repeat procedure for other bearer.

Using coachbolts, fit the router table to the baseboard Fig. 6.

The complete assembly must be firmly secured to the workbench, we recommend the use of 'G' Clamps or similar.

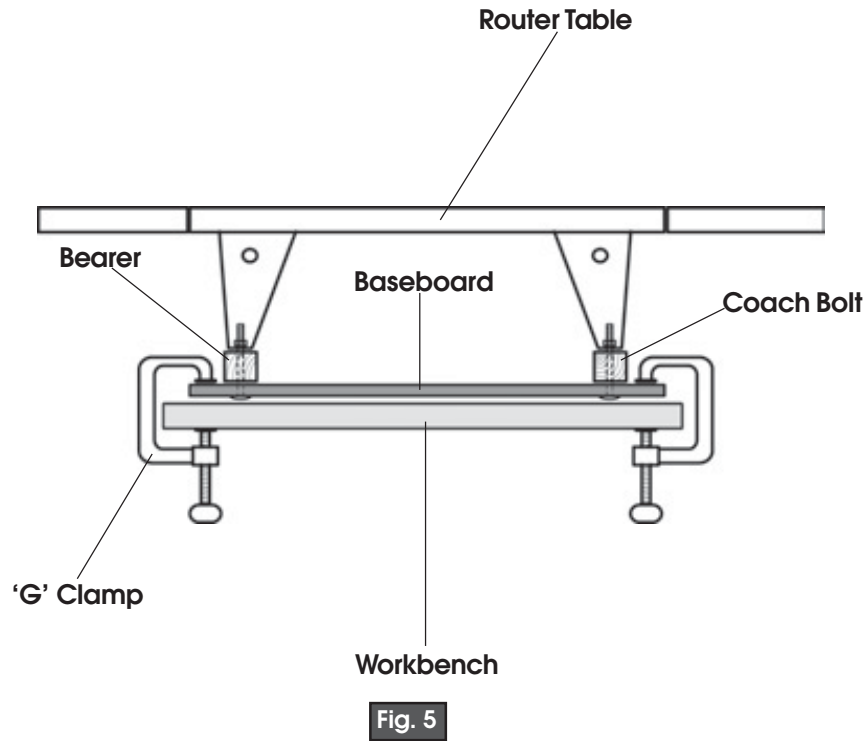

if any rocking is detected, this must be rectified before continuing by loosening the screws on the offending leg/legs and adjusting accordingly. Always take care not to disturb the level of the table extensions to the main table.

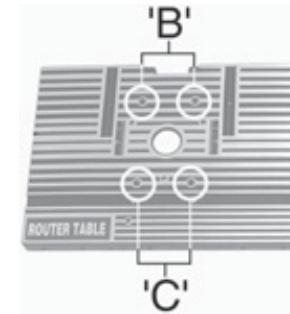

Fig. 4

7. Insert two 50mm long coach bolts into holes 'B' from the top of the table. Fig. 4

4.7 Attach the fence assy (Item 4), using hex head bolt, washer and knob supplied. Insert the bolts from the underside of the table through the holes marked 'A' (Fig. 5). Place the fence on the bolt and secure in position with washer and locking knob.

**DO NOT overtighten.**

**Note:** use the graduated marks to line up the fence accurately.

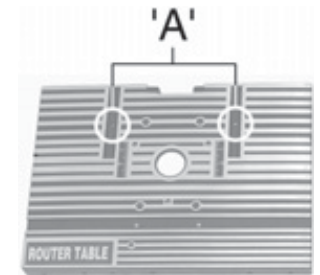

Fig. 5

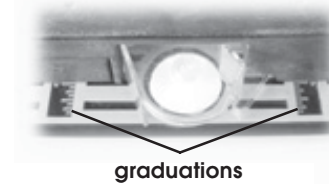

Fig. 6

4.8 Fit the fence feather boards as shown in Fig. 7 using fixings supplied (hex head bolt x 4, washer x 4 and knob x 4). Pay attention to the feed direction.

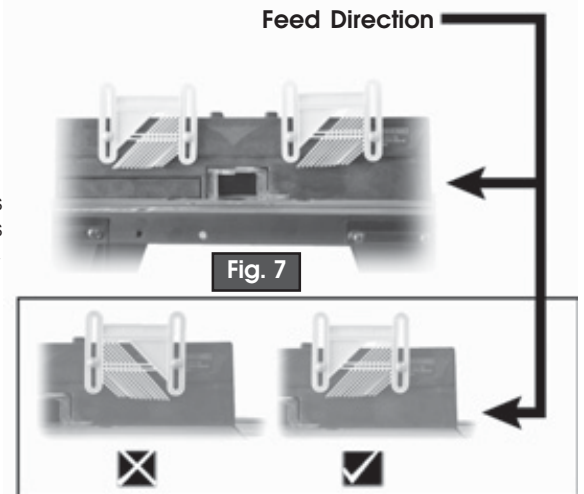
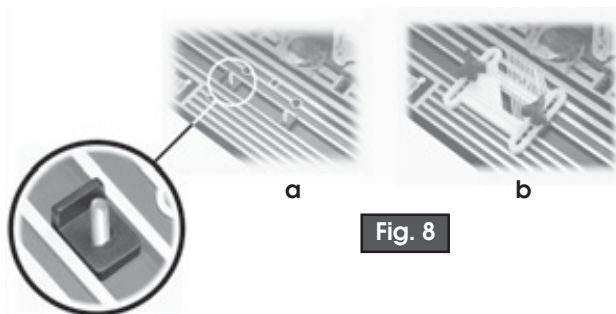

Fig. 7

4.9 Fit the table feather board as shown in Fig. 7 using fixings supplied, again pay attention to the feed direction.



Insert the two hex head bolts from the underside of the table pictured in Fig. 8a, place spacers on the bolts ensuring the correct orientation, place the feather board on top, place washer on each bolt and secure with knobs. Fig. 7b.

**DO NOT overtighten.**

4.10 Fit the switch assembly as follows.

- Unwrap the power cord.
- Fit in position, see Fig. 9 with two phillips head screws inserted from the front of the table secured with two washers and locknuts, (supplied).

**DO NOT overtighten.**



## 5. Mounting The Router

Attach the router to the router table as follows.

5.1 Loosen the fence securing knobs and slide fence forward as far as possible, this prevents the router clamping bolts (50mm coachbolts) from falling through the table when it is turned over.

Carefully turn the table assy over and support by laying it onto suitable sized blocks of wood or similar. see Fig. 10.

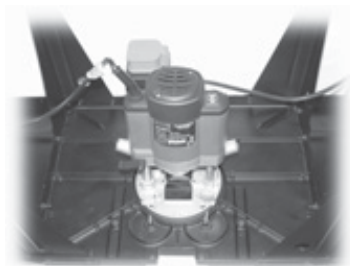

Fig. 11

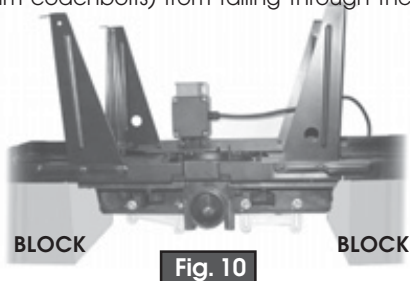
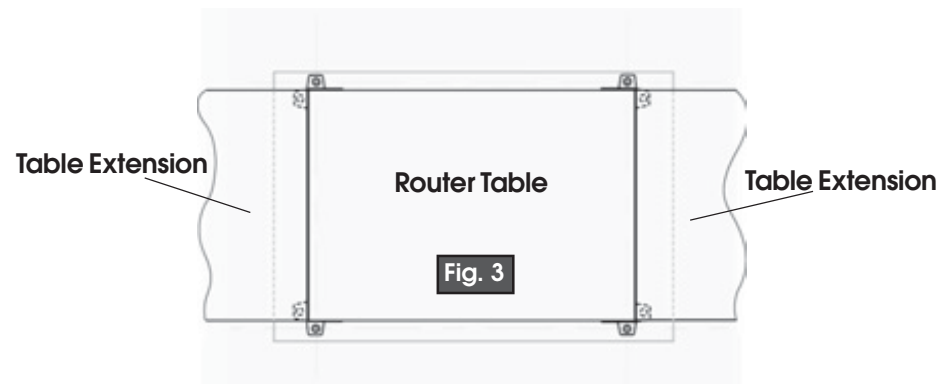

Fig. 10

5.2 Place the router in position on the underside of the table as central as possible, see Fig. 11. Insert two coach bolts into holes 'C' fig. 4 from the table top, now underneath.

Loosely secure router in position with clamps x 4 (Item 9). see Fig. 12.

Centralise the router table feet on the baseboard as indicated in Fig.3



Once the table is centralised on the baseboard, carefully, ensuring the table doesn't move, mark the four holes (X) to be drilled, using the table feet as a template Fig. 4.

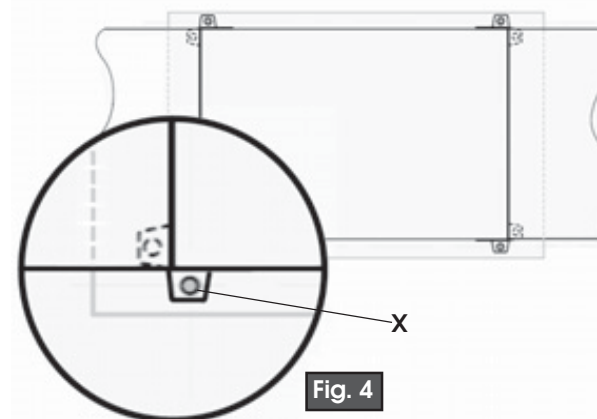

Remove the table and drill the four holes in the baseboard, using a 6mm drill.

Place one of the bearers onto the baseboard as centrally as possible over two of the holes Fig. 5.

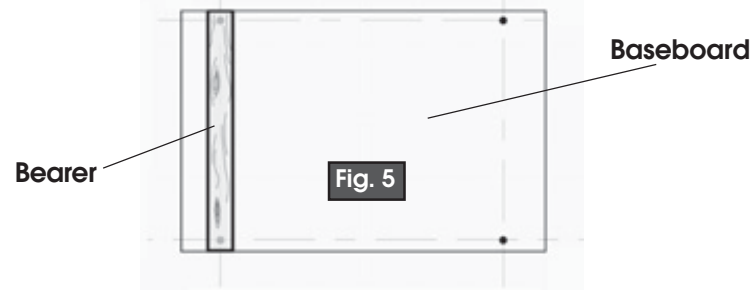



## 7. Height Adjustment

Instructions for routers too long to fit underneath the router table.

It is possible to overcome this problem by carrying out the following.

**NOTE:** the following dimensions are the minimum sizes recommended, which can be increased if desired.

### Materials Required

1 off plywood baseboard 13mm (1/2") x 400mm x 600mm.

2 off timber bearers 50mm x 50mm x 400mm.

2 off 5mm coachbolts x 75mm.

Lightly mark the hole centres in the baseboard as per the Fig. 2, **DO NOT DRILL.**

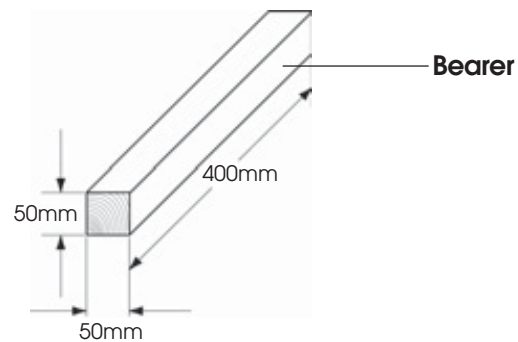

Fig. 1

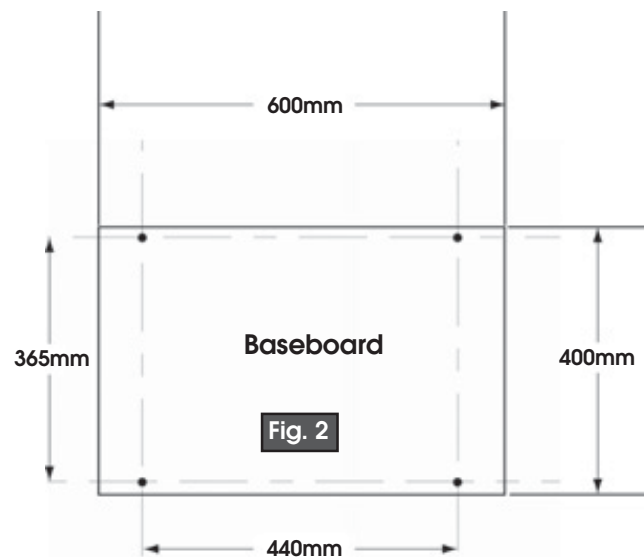

Fig. 2

It may be necessary to rotate the router in order to locate all four clamps correctly. If router is fitted with a speed control, try if possible to position the speed control where it can easily be accessed from the front of the table. Once the router is in the desired position, tighten the four clamps sufficiently to prevent the router moving whilst in operation.



Fig. 12



Fig. 13

- 5.3 Plug the 13amp router plug into the bottom of the switch assembly, loosely tidy up the router power cord and secure safely with cable tie or similar, see Fig. 13.

For your personal safety and that of others around you, the router table should be securely anchored when in use, this can be achieved by bolting or screwing it to the work bench through the holes in the router table feet, alternatively the table can be bolted onto a suitable board and clamped to the workbench etc with 'G' clamps or similar.

Your router table is now fully assembled and ready for use.

**NOTE:** Some routers are too long to fit underneath the router table, see page 12 for suggestion to overcome this problem.

## 6. Operation

### IMPORTANT

When making adjustments etc, **ALWAYS** ensure the router is isolated from the main electrical supply by switching off and removing the plug from the socket.

**NOTE:** Always refer to the specific router operating instruction manual when making height and speed adjustments etc.

### Installing The Router Cutter (Bit)

To install bits whilst the router is in situ will require the router to be lowered fully. Select desired bit and install. Fit the table insert closest to the size of the bit, ensure the bit does not touch the insert.

### Height Adjustment

Raise the router until the bit protrudes through the table the required amount. When making height adjustments, ensure the cutter does not touch the transparent retractable guard, operate the guard manually and check the guard moves freely.

Make test cuts on scrap pieces of wood to set accurately.

### **Fence adjustment**

Loosen the two fence clamping knobs and position the fence as desired, use the graduation marks to set the fence parallel, see Fig. 6.

Make test cuts on scrap pieces of wood to set accurately.

### **Feather Boards**

Set the fence feather boards to hold the piece of wood flat on the table and against the fence whilst machining.

To do this, place the piece of wood against the fence and bellow the relevant pad to be adjusted, loosen the two wingnuts and lower the pad until it rests on the wood, push the pad down a little further to apply sufficient pressure to hold the wood flat on the table.

Repeat the above procedure for the other fence board.

Adjust the table feather board in the same manner to hold the wood firmly against the fence.

### **Jointing Fence**

Set the jointing fence to support the wood when cutting the full thickness. Adjust the cutting depth etc as previously described, proceed to machine the piece of wood until the lead edge passes over the jointing fence by approx 25mm (1"). Switch off and isolate from the main electrical supply. Hold the wood firmly against the Fence, loosen the jointing fence clamping knob, slide the jointing fence out towards the wood until it touches, tighten the clamping knob.

Back the workpiece away from the cutter before switching on again and continuing machining.

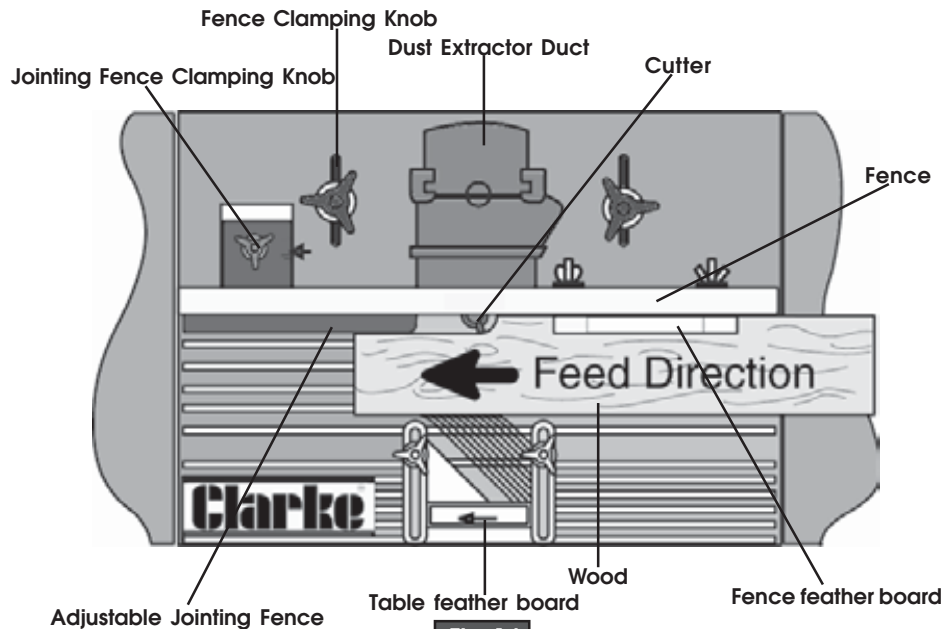

**Fig. 14**

### **Mitre Gauge**

To use the mitre gauge, the table feather board must be removed first, it may be necessary to loosen the front clamps holding the router in order to remove the bolts, not forgetting to retighten them before using the router again.

To use the gauge, simply slot it into the front slot on the table, adjust to the required angle, the gauge is now ready for use.

Switch the router ON, firmly hold the workpiece in position against the mitre gauge fence, see Fig. 15 and slowly move it across the table.



**Fig. 15**

### **IMPORTANT**

As with all power tools, especially those with cutters/blades, keep hands and fingers safely away from blades by using push sticks etc when working on small workpieces.

### **Dust Extraction**

The router table is provided with a dust extraction facility, where a vacuum extractor may be connected to the outlet at the rear of the table, using the adapter supplied.

The connection hose requires an inside diameter of 34mm to fit the adapter supplied, the hose, ideally should be a reasonably tight fit on the adapter, which is then just pushed into the hole in the back of the table.

Note however, that this does not preclude the user from wearing a face mask to prevent the inhalation of dust particles.

It is a requirement that a dust extraction facility be provided on power tools, however, due to the nature of the tool, some of the dust produced will be forced into the surrounding atmosphere, and will not be collected.