

Clarke[®] INTERNATIONAL

Model No: CPP3000B
Drill-Powered Pump
Part No. 7210102



Thank you for purchasing this CLARKE Drill Powered Pump.

This extremely versatile pump is designed for use in the home for pumping flooded cellars, emptying fish tanks, blocked sinks, baths or washing machines, in the garden for emptying ponds, or paddling pools, irrigation or transferring insecticides, on boats for emptying bilge water etc., and in any operation requiring the transfer of liquids other than petrol and other flammable substances, (see Safety Precautions).

The pump is simple to use, but you should nevertheless read this leaflet thoroughly and follow the instructions carefully. In doing so you will ensure the safety of yourself and that of others around you, and you can look forward to the pump giving you long and satisfactory service.

Guarantee

This CLARKE product is guaranteed against faulty manufacture for a period of 12 months from the date of purchase. Please keep your receipt as proof of purchase. This guarantee is invalid if the product is found to have been abused or tampered with in any way, or not used for the purpose for which it was intended.

Faulty goods should be returned to their place of purchase. No product can be returned to us without prior permission. This guarantee does not affect your statutory rights.

Parts & Service: 020 8988 7400/E-mail:Parts@clarkeinternational.com or Service@clarkeinternational.com

Specifications

- Operating Speed Range 2,000 - 3,000 RPM
- Min. Drill Power rating 350 Watts
- Capacity 40 - 50 litres/min*
- Hose Diameter 20mm (3/4")
- Max. Inlet Head 2 metres (Water)
- Max. Delivery Head 15 metres (Water)
- Operating Temp. Range. 5 - 60°C

* Without filter

WARNING

This pump is not designed for pumping petrol, paraffin or other flammable or acid based liquids.



Safety Precautions

- DO NOT allow the pump to run dry.
- DO NOT operate at speeds greater than 3,000RPM.
- DO NOT pump liquids contaminated with solids, without a filter being fitted to the inlet hose.
- In addition to petrol or other flammable liquids, and acids, or DO NOT pump liquids that leave a residue upon drying.
- ALWAYS keep your feet and hands dry when using the drill pump.
- ALWAYS ensure the drill is kept dry and is correctly earthed - preferably use a drill which is double insulated.
- Make absolutely sure that there is no possibility of the pump and drill vibrating its way into the liquid.
- As the device is to be used in the close proximity to water, the drill should always be connected to the mains supply through a residual current circuit breaker (RCCB or RCD).

Contents List

1. Pump Body
2. 'U' Bolt w/washers and nuts
3. Gauze Filter
4. 4 x replacement Vane Seals
4. 'O' Ring

Instructions for use

1. Attach suitable 3/4" dia hose to the inlet and outlet ports using worm drive clips, (not supplied), ensuring they are completely air tight. The inlet port is marked 'IN' and the outlet port 'OUT'. The inlet hose be completely sound with no pin holes. Test it prior to use by blocking off one end and blowing into it. Always attach the filter (provided), to the foot of the hose, as shown in the diagram. Use a suitable adhesive (not supplied) to ensure it is firmly and permanently attached.

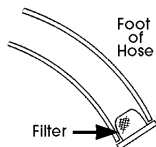

2. Install the pump in the chuck of a suitable drill, with the drill disconnected from the mains supply.

NOTE: While the pump can be held by hand during fairly short periods of operation, for extra stability it is advised that the pump be attached to

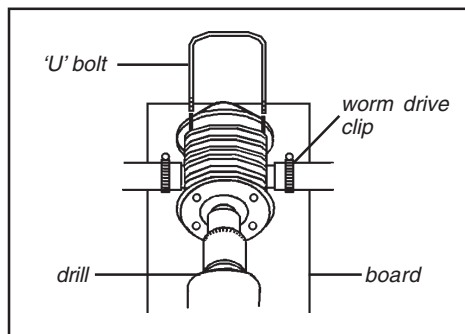

a board using the 'U' bolt supplied, as shown in the diagram. If necessary weigh the board down or secure it in some way to prevent it from moving during operation.

When securing the pump to a board, ensure the pump and drill remain perfectly in line. Do not under any circumstances tighten down the 'U' bolt in such a way as to cause the pump and drill to become 'bowed'. The drill should be free to move but have its weight supported, keeping it perfectly in line with the pump.

3. Insert the inlet hose into the liquid with the pump as near to it as possible bearing in mind that the maximum lifting height is 2 metres.

Parts & Service: 020 8988 7400/E-mail:Parts@clarkeinternational.com or Service@clarkeinternational.com

Ensure also that the outlet hose is led away to a suitable place of discharge. If a long hose is used, ensure that there is no likelihood of it becoming damaged or blocked by vehicles or other means. The maximum height to which the pump will deliver water is 15 metres.

4. When installation is complete, plug the drill into the mains supply and switch on.

NOTE: If the pump does not prime and begin to deliver liquid within 10 seconds, switch off and investigate the cause.

The most common cause is leaks on the inlet side of the pump, is where air is being drawn in through a damaged or insecure hose.

Other causes are - blocked inlet or outlet pipes, trying to draw from too great a height (2M max.), or deliver to too great a height (15M max.), drill power too low, or worn pump seals.

WARNING: 'The outlet flow from this pump must not be restricted in any way either during or prior to use'.

Do not connect the outlet of this pump to a system that restricts its flow or has a head height greater than 1.5 metres.

Maintenance

To prolong the life of the pump, always flush thoroughly with a water/detergent solution and then with water only. Finally, apply a few drops of light lubricating oil into the inlet port, rotating the drive shaft by hand as you do so.

Store in a dry cool location. Do not leave exposed to the elements.

Four vane seals, together with an end plate 'O' Ring and a shaft seal, are provided should the pump require servicing.

To replace the vane seals, remove the four screws securing the end cover, - at the SHAFT end of the pump, and withdraw the shaft complete with vanes from the pump body.

Pull out the vane seals and replace with new ones.

Renew the large 'O' ring on the inside face of the end cover and apply silicon grease to the vanes, ensuring they are perfectly free to move, before reassembly.

Before fitting the four end cover screws, twist the end plate whilst applying gentle pressure, to ensure the locating dowels seat correctly.

Tighten the four end cover screws progressively, taking care not to overtighten them as this could distort the body of the pump and cause severe damage, possibly rendering the pump inoperable.