

# Clarke<sup>®</sup> CONTRACTOR<sup>®</sup>



**185MM CIRCULAR SAW WITH LASER GUIDE**  
**MODEL NO: CON185**

PART NO: 6462500

**OPERATION & MAINTENANCE  
INSTRUCTIONS**



LS0112

---

## INTRODUCTION

---

Thank you for purchasing this CLARKE 185mm Circular Saw with Laser Guide.

Before attempting to use this product, please read this manual thoroughly and follow the instructions carefully. In doing so you will ensure the safety of yourself and that of others around you, and you can look forward to your purchase giving you long and satisfactory service.

---

## GUARANTEE

---

This product is guaranteed against faulty manufacture for a period of 12 months from the date of purchase. Please keep your receipt which will be required as proof of purchase.

This guarantee is invalid if the product is found to have been abused or tampered with in any way, or not used for the purpose for which it was intended.

Faulty goods should be returned to their place of purchase, no product can be returned to us without prior permission.

This guarantee does not effect your statutory rights.

---

## SPECIFICATIONS

---

Model Number	CON185
Rated Voltage	230V~50Hz
Power Input	1600 W
No Load Speed	5000 RPM
Maximum Depth of Cut	60 mm @ 90° - 40 mm @ 45°
Blade Dimensions	185 mm Ø x 2.4 mm (thickness) x 16 mm Bore
Sound Pressure Level LpA	93.4 dB(A)
Sound Power Level LWA	104.4 dB(A)
Uncertainty Factor (K)	3 dB(A)
Weight	4.85 kg
Vibration	2.234 m/s <sup>2</sup> Uncertainty Factor 1.5
Dimensions (L x W x H)	310 mm x 245 mm x 243 mm

---

# POWER TOOL SAFETY WARNINGS

---

## WORK AREA

1. **Keep the work area clean and well lit.** Cluttered and dark areas invite accidents.
2. **Do not operate power tools in explosive atmospheres, such as in the presence of flammable liquids, gases or dust.** Power tools create sparks which may ignite the dust or fumes.
3. **Keep children and bystanders away while operating a power tool.** Distractions can cause you to lose control.

## ELECTRICAL SAFETY

1. **Power tool plugs must match the outlet. Never modify the plug in any way. Do not use adaptor plugs with earthed (grounded) power tools.** Unmodified plugs and matching outlets will reduce the risk of electric shock.
2. **Do not expose power tools to rain or wet conditions.** Water entering a power tool will increase the risk of electric shock.
3. **Do not abuse the cable. Never use it for carrying, pulling or unplugging the power tool. Keep the cable away from heat, oil, sharp edges or moving parts.** Damaged or entangled cables increase the risk of electric shock.
4. **When operating a power tool outdoors, use an extension cable suitable for outdoor use.** Use of a cable suitable for outdoor use reduces the risk of electric shock.
5. **If operating the power tool in a damp location is unavoidable, use a residual current device (RCD) protected supply.**

## PERSONAL SAFETY

1. **Stay alert, watch what you are doing and use common sense when operating a power tool.** Do not use a power tool while you are tired or under the influence of drugs, alcohol or medication. A moment of inattention while operating power tools may result in personal injury.
2. **Use safety equipment. Always wear eye protection.** Safety equipment such as dust mask, non-skid safety shoes, hard hat, or hearing protection used for appropriate conditions will reduce personal injuries.
3. **Avoid accidental starting.** Ensure the switch is in the off position before plugging in. Carrying power tools with your finger on the switch or plugging in power tools that have the switch on invites accidents.
4. **Remove any wrench before turning the power tool on.** A wrench left attached to a rotating part may result in personal injury.
5. **Do not overreach.** Keep proper footing and balance at all times. This enables better control of the power tool in unexpected situations.
6. **Dress properly.** Do not wear loose clothing or jewellery. Keep your hair, clothing and gloves away from moving parts. Loose clothes, jewellery or long hair can be caught in moving parts.

## POWER TOOL USE AND CARE

1. **Do not force the power tool.** Use the correct accessories for your application. The correct power tool will do the job better and safer at the rate which it was designed for.
2. **Do not use the power tool if the switch does not turn it on and off.** Any power tool that cannot be controlled with the switch is dangerous and must be repaired.
3. **Disconnect the plug from the power source before changing accessories, or storing power tools.** Such preventive safety measures reduce the risk of starting the power tool accidentally.
4. **Store idle tools out of the reach of children and do not allow persons unfamiliar with the power tool or these instructions to operate it.** Power tools are dangerous in the hands of untrained users.
5. **Maintain power tools.** Check for misalignment or binding of moving parts, breakage of parts and any other condition that may affect the power tool's operation. If damaged, have the power tool repaired before use. Many accidents are caused by poorly maintained power tools.
6. **Use the power tool and accessories in accordance with these instructions and in the manner intended, taking into account the working conditions and the work to be performed.** Use of the power tool for operations different from intended could result in a hazardous situation.
7. The performance of this tool may vary, depending upon variations in line voltage. Extension cable usage may also affect performance.

## SERVICE

1. **Have your power tool serviced by qualified service personnel using only identical replacement parts.** This will ensure that the safety of the power tool is maintained.

---

## SAFETY INSTRUCTIONS FOR ALL SAWS

---

- a. **Keep hands away from cutting area and the blade.** Keep your second hand on the auxiliary handle, or motor housing. If both hands are holding the saw, they cannot be cut by the blade.
- b. **Do not reach underneath the workpiece.** The guard cannot protect you from the blade below the workpiece.
- c. **Adjust the cutting depth to the thickness of the workpiece.** Less than a full tooth of the blade teeth should be visible below the workpiece.
- d. **Never hold the piece being cut in your hands or across your leg.** Secure the workpiece to a stable platform. It is important to support the work properly to minimise body exposure, blade binding, or loss of control.
- e. **Hold the power tool by insulated gripping surfaces when performing an operation.** Contact with a "live" wire will also make exposed metal parts of the power tool "live" and shock the operator.

- f. **Always use blades with the correct size and shape of arbor holes.** Blades that do not match the mounting hardware of the saw will run eccentrically, causing loss of control.
- g. **Never use damaged or incorrect blade washers or bolt.** The blade washers and bolt were specially designed for your saw, for optimum performance and safety of operation.
- h. Do not operate the saw if the guard is damaged or does not operate correctly.
- i. Never use the saw with the guard removed.

## PREVENTION OF KICKBACK

Kickback is a sudden reaction to a pinched, bound or misaligned saw blade, causing an uncontrolled saw to lift up and out of the workpiece toward the operator.

When the blade is pinched or bound tightly by the kerf closing down, the blade stalls and the motor reaction drives the unit rapidly back toward the operator.

If the blade becomes twisted or misaligned in the cut, the teeth at the back edge of the blade can dig into the top surface of the wood causing the blade to climb out of the kerf and jump back toward the operator. Kickback is the result of saw misuse and/or incorrect operating procedures or conditions and can be avoided by taking proper precautions as given below.

- a. Maintain a firm grip with both hands on the saw and position your arms to resist kickback forces. Position your body to either side of the blade, but not in line with the blade.
- b. When the blade is binding, or when interrupting a cut for any reason, release the trigger and hold the saw motionless in the material until the blade comes to a complete stop. Never attempt to remove the saw from the work or pull the saw backward while the blade is in motion or kickback may occur. Investigate and take corrective actions to eliminate the cause of blade binding.
- c. When restarting a saw in the workpiece, centre the saw blade in the kerf and check that saw teeth are not engaged with the material. If the blade is binding, it may walk up or kickback from the workpiece as the saw is restarted.
- d. Support large panels to minimise the risk of blade pinching and kickback. Large panels tend to sag under their own weight. Supports must be placed under the panel on both sides, near the line of cut and near the edge of the panel.
- e. Blade depth and bevel adjusting locking screws must be tight and secure before making a cut. If blade adjustment shifts while cutting, it may cause binding and kickback.
- f. Use extra caution when making a "plunge cut" into existing walls or other blind areas. The protruding blade may cut objects that can cause kickback.

## CIRCULAR SAW BLADE SAFETY WARNINGS

- a. The maximum speed marked on the tool shall not exceed the maximum speed marked on the blade.
- b. Cracked circular saw blades shall be scrapped (repairing is not permitted). Composite (tipped) circular saw blades, where the tip dimension is reduced to less than 1 mm, shall be taken out of service.
- c. Fastening screws and nuts shall be tightened using the tools supplied.
- d. Clamping surfaces shall be cleaned to remove dirt, grease, oil and water.
- e. Do not use loose rings or bushes to "make up" bore sizes on circular saw blades.

---

## EXPLANATION OF SYMBOLS & PICTOGRAMS

---



Read Instruction Manual Before Use



Wear Eye Protection



Wear Ear Defenders



Wear Gloves



Laser Radiation, Class 2 Laser: Do not stare into the beam.

## ELECTRICAL CONNECTIONS



**WARNING: READ THESE ELECTRICAL SAFETY INSTRUCTIONS THOROUGHLY BEFORE CONNECTING THE PRODUCT TO THE MAINS SUPPLY.**

Before switching the product on, make sure that the voltage of your electricity supply is the same as that indicated on the rating plate. This product is designed to operate on 230VAC 50Hz. Connecting it to any other power source may cause damage.

This product may be fitted with a non-rewireable plug. If it is necessary to change the fuse in the plug, the fuse cover must be refitted. If the fuse cover becomes lost or damaged, the plug must not be used until a suitable replacement is obtained.

If the plug has to be changed because it is not suitable for your socket, or due to damage, it should be cut off and a replacement fitted, following the wiring instructions shown below. The old plug must be disposed of safely, as insertion into a mains socket could cause an electrical hazard.



**WARNING: THE WIRES IN THE POWER CABLE OF THIS PRODUCT ARE COLOURED IN ACCORDANCE WITH THE FOLLOWING CODE:  
BLUE = NEUTRAL    BROWN = LIVE**

If the colours of the wires in the power cable of this product do not correspond with the markings on the terminals of your plug, proceed as follows.

- The wire which is coloured **Blue** must be connected to the terminal which is marked **N** or coloured **Black**.
- The wire which is coloured **Brown** must be connected to the terminal which is marked **L** or coloured **Red**.

**Plug must be BS1363/A approved.**

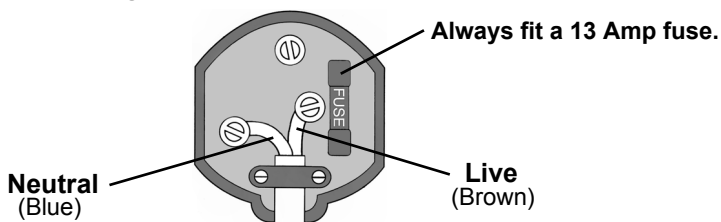

**Ensure that the outer sheath of the cable is firmly held by the clamp**

We strongly recommend that this machine is connected to the mains supply via a Residual Current Device (RCD)



**This symbol indicates that this is a Class II product, and does not require an earth connection.**

# PART IDENTIFICATION.

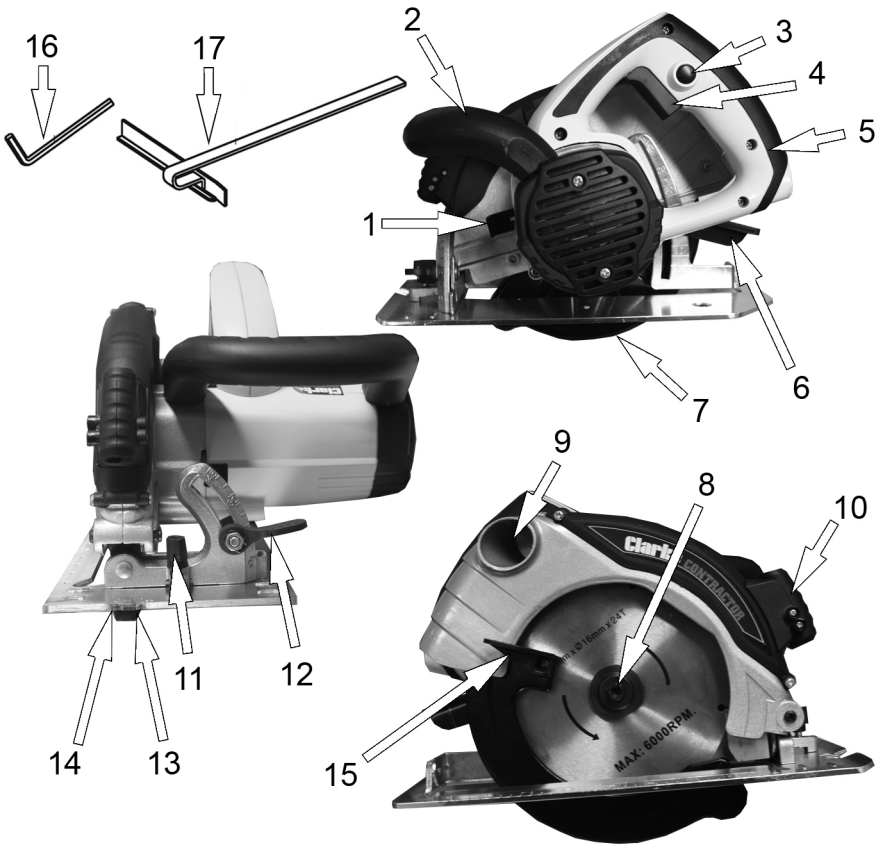

1	Blade Lock	10	Laser Module
2	Auxillary Handle	11	Parallel Guide Locking Screw
3	Safety Lock Button	12	Bevel Adjustment Locking Lever
4	On/Off Trigger	13	Mark For Bevel Cut
5	Handle	14	Mark For Straight Cut
6	Depth Adjustment Lever	15	Lower Guard Retracting Lever
7	Lower Guard	16	Hexagon Key
8	Blade Clamping Screw	17	Parallel Guide
9	Dust Extraction Outlet		



---

## CARTON CONTENTS

---

The following items should be supplied in the carton. If any parts are missing or damaged, please contact the Clarke dealer where you purchased the tool.

- 1 x 1600 Watt Circular Saw.
- 1 x 185 mm Ø x 16 mm Bore x 24 Tooth TCT blade.
- 1 x Parallel Fence.
- 1 x 6 mm Hexagon Key.

---

## ADJUSTMENTS

---

### DEPTH OF CUT ADJUSTMENT

1. Loosen the depth adjustment lever.
2. Adjust the base plate until the required depth of blade is protruding through the base plate.
3. Tighten the depth adjustment lever.

**NOTE:** For optimum results, a full tooth should just be visible below the workpiece.

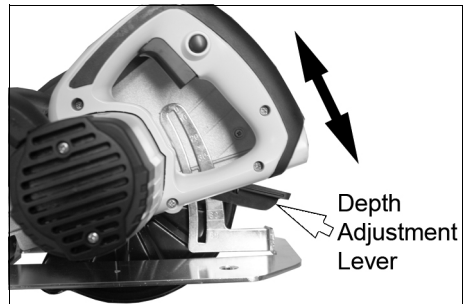

### BEVEL ADJUSTMENT

1. Loosen the bevel adjustment locking lever.
2. Adjust the base plate to the required angle (max 45°)
  - Use the bevel scale as a guide only, for accurate angles use a protractor.
3. Tighten the bevel adjustment locking lever to secure.

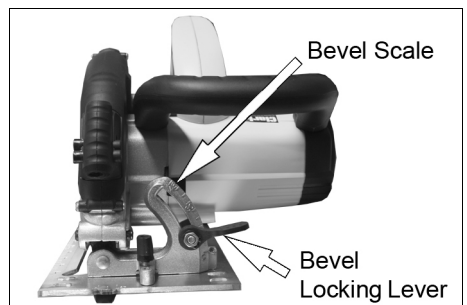

## MOUNTING AND USING THE PARALLEL GUIDE

### MOUNTING

1. Slide the parallel guide into the base plate as shown.
2. Secure in place using the parallel guide locking screw.

### ADJUSTING

1. Loosen the Parallel Guide Locking Screw.
2. Adjust the Parallel Guide to the required length.
  - There is a scale on the parallel guide that can be used to give an approximate guide. Always double check using an accurate ruler.
3. Tighten the Parallel Guide Locking Screw to secure the parallel guide in position.

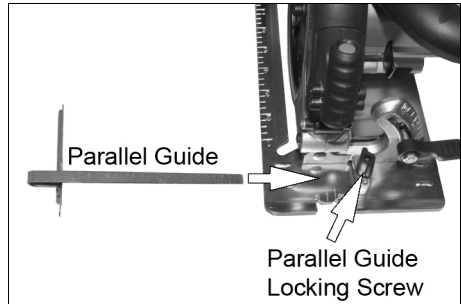

## DUST EXTRACTION

The circular saw can be connected to a dust extraction system, using a suitable hose adaptor (not supplied).

- The internal diameter of the dust extraction outlet is 30 mm.



## THE LASER GUIDE

Your saw is fitted with a laser guide to assist with accurate cutting.

### SWITCHING ON/OFF

Switch the laser on/off using the on/off switch.



# OPERATION & USE

## CORRECT HAND POSITION

For your own safety, always hold the circular saw as shown in this picture, with one hand on the main handle and the other on the auxiliary handle.



## SWITCHING ON/OFF

The on/off trigger is fitted with a safety button which prevents the circular saw from being started accidentally. To start the saw:

1. Press and hold the safety button.
2. Squeeze the on/off trigger at the same time.
3. Release the on/off trigger to stop the saw.
4. The blade will continue to rotate for several seconds after the trigger has been released.

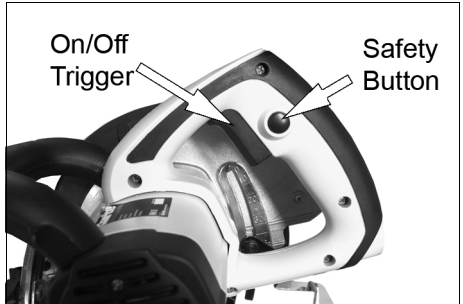

## GUIDING THE CIRCULAR SAW

To achieve optimal results:

- Clamp the workpiece upside down to minimise breakout.
- Follow the line drawn on the workpiece using the 90° mark.
- If cutting a bevel angle of 45°, follow the line drawn on the workpiece using the 45° mark.

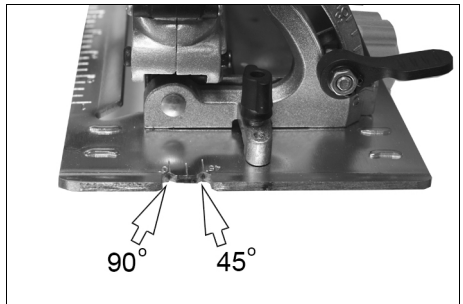

---

# MAINTENANCE

---



**WARNING: DISCONNECT THE CIRCULAR SAW FROM THE MAINS SUPPLY BEFORE FITTING REPLACEMENT BLADES, CLEANING OR ADJUSTMENT.**

---

Keep the machine clean by wiping off dust with a clean cloth.

## BLADE REPLACEMENT

1. Press and hold the Blade lock and remove the blade clamping screw using the hexagon key supplied by turning it anti-clockwise.
  - The blade will rotate until the blade lock is fully engaged.

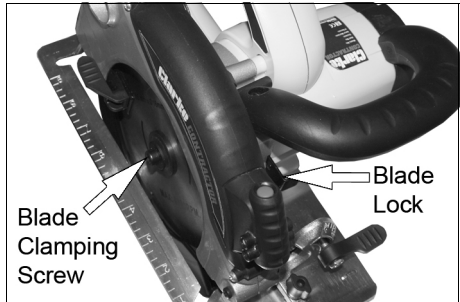

2. Retract the lower blade guard using the retracting lever and replace the blade.
  - Make sure you pay attention to the blade direction marking on the blade.
  - Spare blades are available from your local Clarke dealer.



3. Replace the blade clamping screw by hand until it is holding the blade in position.
4. Press and hold the blade lock and turn the blade by hand until the blade lock is fully engaged.
5. Tighten the blade clamping screw using the hexagon key supplied.

# PARTS DIAGRAM

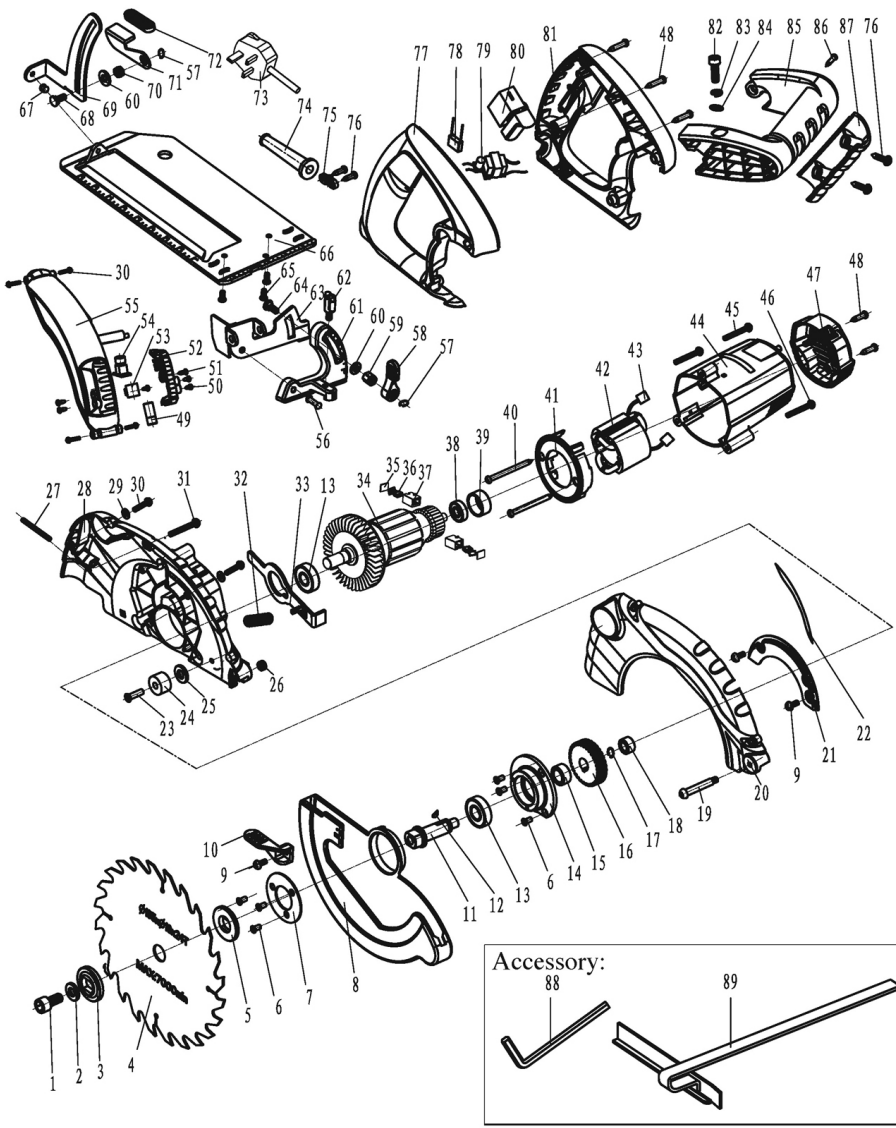

# PARTS LIST

1	Screw	HTCON18501
2	Big Washer	HTCON18502
3	Outer Flange	HTCON18503
4	Blade	HTCON18504
5	Clamping Flange	HTCON18505
6	Screw	HTCON18506
7	Mobile Guard Flange	HTCON18507
8	Blade Upper Guard	HTCON18508
9	Screw	HTCON18509
10	Spanner	HTCON18510
11	Spindle	HTCON18511
12	Key	HTCON18512
13	Bearing	HTCON18513
14	Front Cover	HTCON18514
15	Copper Sleeve	HTCON18515
16	Big Gear	HTCON18516
17	Retaining Ring	HTCON18517
18	Bearing	HTCON18518
19	Screw	HTCON18519
20	Head Cover Board	HTCON18520
21	Small Iron Patch	HTCON18521
22	Specification Lable	HTCON18522
23	Screw	HTCON18523
24	Fixed Ring	HTCON18524
25	Big Washer	HTCON18525
26	Nut	HTCON18526
27	Revived Ring	HTCON18527
28	Head Cover	HTCON18528
29	Spring Washer	HTCON18529
30	Screw	HTCON18530
31	Screw	HTCON18531
32	Self-locking Spring	HTCON18532
33	Self-locking Slice	HTCON18533
34	Rotor	HTCON18534
35	Brush Holder Cover	HTCON18535
36	Carbon Brush	HTCON18536
37	Brush Holer	HTCON18537
38	Bearing 608-2rs	HTCON18538
39	Bearing Cover	HTCON18539
40	Screw	HTCON18540
41	Fan Shroud	HTCON18541
42	Stator	HTCON18542
43	Square Slice	HTCON18543
44	Housing	HTCON18544
45	Screw	HTCON18545
46	Screw	HTCON18546

47	Rear Shade	HTCON18547
48	Screw	HTCON18548
49	Laser Head	HTCON18549
50	Screw	HTCON18550
51	Screw	HTCON18551
52	Laser Side Cover	HTCON18552
53	Laser Set	HTCON18553
54	Laser Switch	HTCON18554
55	Laser Base	HTCON18555
56	Nut	HTCON18556
57	Bearing Circle Board	HTCON18557
58	Angle Lock Spanner	HTCON18558
59	Long Nut	HTCON18559
60	Flat Washer	HTCON18560
61	Angle Shelf	HTCON18561
62	Terse Button	HTCON18562
63	Angle Bracket	HTCON18563
64	Bolt	HTCON18564
65	Screw	HTCON18565
66	Aluminum Table	HTCON18566
67	Nut	HTCON18567
68	Square Screw	HTCON18568
69	Depth Bracket	HTCON18569
70	Special Nut	HTCON18570
71	Depth Lock Spanner	HTCON18571
72	Depth Lock Spanner Sleeve	HTCON18572
73	Cable	HTCON18573
74	Cable Sleeve	HTCON18574
75	Cable Flange	HTCON18575
76	Screw	HTCON18576
77	Right Hand Shank	HTCON18577
78	Capacitor	HTCON18578
79	Transformer	HTCON18579
80	Switch	HTCON18580
81	Left Hand Shank	HTCON18581
82	Inner Angle Screw	HTCON18582
83	Spring Washer	HTCON18583
84	Flat Washer	HTCON18584
85	Assist Handle	HTCON18585
86	Screw	HTCON18586
87	Assist Handle Cover	HTCON18587
88	Inner Angle Spanner	HTCON18588
89	Ruler	HTCON18589

# DECLARATION OF CONFORMITY



**Clarke**<sup>®</sup>  
**INTERNATIONAL**

Hemnall Street, Epping, Essex CM16 4LG

## DECLARATION OF CONFORMITY

**This is an important document and should be retained.**

**We hereby declare that this product(s) complies with the following directive(s):**

*2004/108/EC Electromagnetic Compatibility Directive.*

*2006/42/EC Machinery Directive.*

*2006/95/EC Low Voltage Equipment Directive.*

*2002/95/EC Restriction of Hazardous substances.*

**The following standards have been applied to the product(s):**

*EN 60745-1:2009, EN 60745-2-5:2007, EN 55014-1:2006, EN 55014-2:1997+A1:2001,*

*EN 61000-3-2:2006, EN 61000-3-3:1995+A1:2001+A2:2005, EN 60825-1:2007, EN 61010-1:2001.*

The technical documentation required to demonstrate that the product(s) meet(s) the requirement(s) of the aforementioned directive(s) has been compiled and is available for inspection by the relevant enforcement authorities.

The CE mark was first applied in: 2006

**Product Description:** 1600W 185mm 'Contractor' Circular Saw with Laser Guide.  
1200W 185mm Circular Saw.

**Model number(s):** CCS185  
CON185

**Serial / batch Number:** N/A

**Date of Issue:** 09/09/2011

**Signed:**

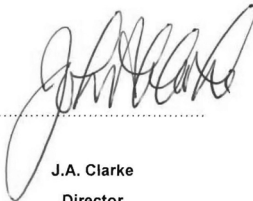

.....  
J.A. Clarke  
Director

# A SELECTION FROM THE VAST RANGE OF

# Clarke®

## QUALITY PRODUCTS

### AIR COMPRESSORS

From DIY to industrial, Plus air tools, spray guns and accessories.

### GENERATORS

Prime duty or emergency standby for business, home and leisure.

### POWER WASHERS

Hot and cold, electric and engine driven - we have what you need

### WELDERS

Mig, Arc, Tig and Spot. From DIY to auto/industrial.

### METALWORKING

Drills, grinders and saws for DIY and professional use.

### WOODWORKING

Saws, sanders, lathes, mortisers and dust extraction.

### HYDRAULICS

Cranes, body repair kits, transmission jacks for all types of workshop use.

### WATER PUMPS

Submersible, electric and engine driven for DIY, agriculture and industry.

### POWER TOOLS

Angle grinders, cordless drill sets, saws and sanders.

### STARTERS/CHARGERS

All sizes for car and commercial use.

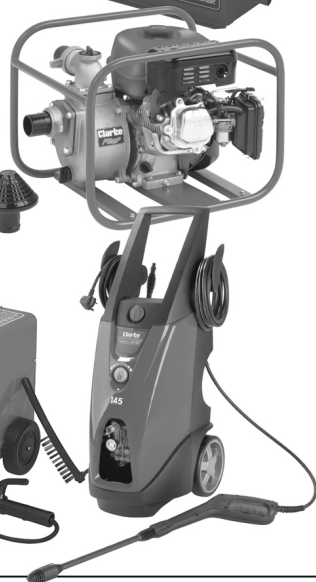

**PARTS & SERVICE: 020 8988 7400**  
E-mail: [Parts@clarkeinternational.com](mailto:Parts@clarkeinternational.com) or [Service@clarkeinternational.com](mailto:Service@clarkeinternational.com)  
**SALES: UK 01992 565333 or Export 00 44 (0)1992 565335**

**Clarke® INTERNATIONAL** Hemnall Street, Epping, Essex CM16 4LG  
[www.clarkeinternational.com](http://www.clarkeinternational.com)