

# Clarke® CONTRACTOR®



**850W RECIPROCATING SAW**

**Model No. CON850**

**PART NO: 6459010**

**OPERATING & MAINTENANCE  
INSTRUCTIONS**



---

## INTRODUCTION

---

Thank you for purchasing this CLARKE Reciprocating Saw.

Before attempting to use the machine, please read this manual thoroughly and follow the instructions carefully. In doing so you will ensure the safety of yourself and that of others around you, and you can look forward to your purchase giving you long and satisfactory service.

---

## GUARANTEE

---

This product is guaranteed against faulty manufacture for a period of 12 months from the date of purchase. Please keep your receipt which will be required as proof of purchase.

This guarantee is invalid if the product is found to have been abused or tampered with in any way, or not used for the purpose for which it was intended.

Faulty goods should be returned to their place of purchase, no product can be returned to us without prior permission.

This guarantee does not effect your statutory rights.

---

## ENVIRONMENTAL RECYCLING POLICY

---



Through purchase of this product, the customer is taking on the obligation to deal with the WEEE in accordance with the WEEE regulations in relation to the treatment, recycling & recovery and environmentally sound disposal of the WEEE.

In effect, this means that this product must not be disposed of with general household waste. It must be disposed of according to the laws governing Waste Electrical and Electronic Equipment (WEEE) at a recognised disposal facility.

---

# TABLE OF CONTENTS

---

<b>INTRODUCTION .....</b>	<b>2</b>
<b>GUARANTEE .....</b>	<b>2</b>
<b>ENVIRONMENTAL PROTECTION .....</b>	<b>2</b>
<b>TABLE OF CONTENTS .....</b>	<b>3</b>
<b>GENERAL SAFETY RULES .....</b>	<b>4</b>
<b>RECIPROCATING SAW SAFETY INSTRUCTIONS .....</b>	<b>6</b>
<b>ELECTRICAL CONNECTIONS .....</b>	<b>7</b>
<b>OVERVIEW .....</b>	<b>8</b>
<b>BEFORE USE .....</b>	<b>9</b>
INSTALLING/CHANGING BLADES .....	9
ADJUSTING THE SHOE .....	9
<b>OPERATION .....</b>	<b>10</b>
PRIOR TO CUTTING .....	10
USING THE SAW .....	10
CUTTING DIFFERENT MATERIALS .....	11
<b>FAULT FINDING .....</b>	<b>12</b>
<b>MAINTENANCE .....</b>	<b>12</b>
CLEANING .....	12
GENERAL MAINTENANCE .....	13
<b>SPECIFICATION .....</b>	<b>13</b>
<b>PARTS DIAGARAM/LIST .....</b>	<b>14</b>
<b>CONSUMABLE SPARE PARTS .....</b>	<b>16</b>
<b>VIBRATION EMISSIONS .....</b>	<b>17</b>
<b>DECLARATION OF CONFORMITY .....</b>	<b>19</b>

---

# GENERAL SAFETY RULES

---

## WORK AREA

1. **Keep the work area clean and well lit.** Cluttered and dark areas invite accidents.
2. **Do not operate power tools in explosive atmospheres such as in the presence of flammable liquids, gasses or dust.** Power tools create sparks which may ignite dust or fumes.
3. **Keep children and bystanders away while operating a power tool.** Distractions can cause you to lose control.

## ELECTRICAL SAFETY

1. **Power tools must match the power outlet. Never modify the plug in any way. Do not use adaptor plugs with earthed (grounded) power tools.** Correct plugs and outlets will reduce the risk of electric shock.
2. **Do not expose power tools to rain or wet conditions.** Any water entering power tools will increase the risk of electric shock.
3. **Do not abuse the electrical cable. Never use the cord for pulling or unplugging the power tool. Keep the cable away from sources of heat, oil, sharp edges or moving parts.** Damaged or tangled cables increase the risk of electric shock.
4. **Use outdoor extension leads.** If working outdoors, always use an approved cable extension suitable for the power rating of this tool (see specifications), the conductor size should also be at least the same size as that on the machine, or larger. When using a cable reel, always unwind the cable completely. We strongly recommend that this machine is connected to the mains supply via a Residual Current Device (RCD).

## PERSONAL SAFETY

1. **Stay alert, watch what you are doing and use common sense when you are operating a power tool.** Do not operate a power tool when you are tired, ill or under the influence of alcohol, drugs or medication.
2. **Wear personal protective equipment including eye protection.** Safety equipment such as a dust mask, non-skid shoes or hearing protection used for appropriate conditions will reduce personal injuries. Use a face or dust mask if operation is particularly dusty. Wear ear protectors/defenders as the noise level of this machine can exceed 85dB (A).
3. **Do not over-reach.** Keep your proper footing and balance at all times. This enables better control of the power tool in unexpected situations.
4. Concentrate on the job in hand, no matter how trivial it may seem. Be aware that accidents are caused by carelessness due to familiarity.

5. **Dress properly.** Do not wear loose clothing or jewellery which may get caught in moving parts. Wear protective hair covering to contain long hair. For best footing, wear rubber soled footwear. Keep floor clear of oil, scrap wood, etc.
6. **Avoid accidental starting of the machine.** Ensure the switch is in the off position and the locking button disengaged before plugging the machine in to the power supply. Carrying power tools around with your finger on the trigger or plugging in power tools that are switched on invites accidents.
7. Switch the machine OFF immediately after the task is completed.

## POWER TOOL USE AND CARE

1. **Do not force the machine.** Use the correct power tool for your application. It will do a better and safer job at the rate for which it was designed.
2. **Do not use the power tool if the switch does not turn it on and off.** Any power tool that cannot be controlled with the switch is dangerous and must be repaired.
3. **Disconnect the power tool from the power supply before making any adjustments, changing accessories, or storing the tool.** These measures will reduce the risk of the power tool starting accidentally.
4. **Store power tools out of the reach of children and do not allow persons unfamiliar with these instructions to operate the power tool.** Power tools are potentially dangerous in the hands of untrained users.
5. **Maintain power tools in top condition.** Keep tools/ machines clean for the best and safest performance. Check for misalignment or binding of moving parts, broken parts, or any condition that may affect the power tool's operation. If damaged, have the power tool repaired before use. Many accidents are caused by poorly maintained power tools.
6. **Use recommended accessories.** The use of improper accessories could be hazardous.
7. **Machine cleanliness.** Do not allow the ventilation slots in the machine to become blocked with dust.
8. **Check the power tool for damage before using the machine.** Any damaged part should be inspected to ensure that it will operate properly and perform its intended function. Check for alignment of moving parts, breakage of parts, mountings, and any other condition that may affect the machine's operation. Any damage should be properly repaired or the part replaced. If in doubt, **DO NOT** use the machine. Consult your local dealer.

## SERVICE

1. **When necessary, have your power tools serviced or repaired by a qualified person using identical replacement parts.** This will ensure that the safety of the power tool is maintained.

---

# RECIPROCATING SAW SAFETY INSTRUCTIONS

---

1. **Only use the saw as described in these instructions.**

## CHANGING BLADES

2. **Unplug the saw before changing blades**, and take care to prevent entrapment of the fingers between the blade and the shoe. Ensure the blade is secure before use.
3. **Use the appropriate saw blade for the material being cut.** Different blades are available from your Clarke dealer.
4. **Only use saw blades in perfect working condition.** Discard and replace any cracked or bent saw blades.

## WHEN SAWING

5. **Use of the mains cable.** Keep the mains cable well away from the saw blade and ensure an adequate electrical supply is close at hand so that the operation is not restricted by the length of the cable.
6. **Working on the bench.** Allow sufficient clearance beneath the work to ensure the blade does not come into contact with the floor, bench etc.
7. **Switching off.** Never place the saw on a table or bench if it has not completely stopped. The saw blade will continue to reciprocate for a short time after the trigger has been released to stop the saw.
8. **Cutting of pipes.** Do not cut hollow pipe and do not cut material above the specified thickness.
9. **Cutting into walls.** Do not cut through walls or cavities before checking for hidden electrical wires or water pipes etc.
10. **Finishing cutting.** Do not remove tool from work until the blade has completely stopped and allow time for it to cool before touching the blade immediately after use.
11. **Use clamps & vices wherever possible.** Use clamps and vices to secure the workpiece.
12. **Cutting sheet materials.** Do not cut work less than at least twice the pitch of the saw blade. i.e. at least two teeth must be in contact with the work at all times.
13. **Beware of foreign objects.** When cutting pre-used wood, ensure all nails have been removed beforehand. Nails will damage the wood saw blade.
14. **Cooling agents.** When cutting metals, always use a cooling agent i.e. cutting/soluble oil.
15. Do not attempt to saw very small objects including those which cannot be properly secured. Always hold the saw with both hands.

**Please keep these instructions in a safe place for future reference.**

## ELECTRICAL CONNECTIONS



**WARNING! Read these electrical safety instructions thoroughly before connecting the product to the mains supply.**

Before switching the product on, make sure that the voltage of your electricity supply is the same as that indicated on the rating plate. This product is designed to operate on 230VAC 50Hz. Do not connect it to any other power source.

This product may be fitted with a non-rewireable plug. If it is necessary to change the fuse in the plug, the fuse cover must be refitted. If the fuse cover becomes lost or damaged, the plug must not be used until a suitable replacement is obtained.

If the plug has to be changed because it is not suitable for your socket, or due to damage, it should be cut off and a replacement fitted, following the wiring instructions shown below. The old plug must be disposed of safely, as insertion into a mains socket could cause an electrical hazard.



**WARNING! The wires in the power cable of this product are coloured in accordance with the following code:**

**Blue = Neutral      Brown = Live**

If the colours of the wires in the power cable of this product do not correspond with the terminal markings of your plug, proceed as follows.

- **The wire which is coloured Blue must be connected to the terminal which is marked N or coloured Black.**
- **The wire which is coloured Brown must be connected to the terminal which is marked L or coloured Red.**

**Plug must be BS1363/A approved.**

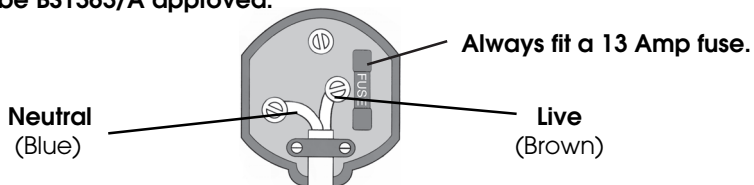

**Ensure that the outer sheath of the cable is firmly held by the clamp**

We strongly recommend that this product is connected to the mains supply via a Residual Current Device (RCD).

If in doubt, consult a qualified electrician. DO NOT attempt repairs yourself.



This symbol indicates that this is a Class II product and does not require an earth connection.

## OVERVIEW

The CLARKE CON850 is a variable-speed reciprocating saw fitted with a lock-on button for continuous operation. The saw is equipped with a quick-release blade retention system for convenient replacement of saw blades.

When unpacking, check for damage or shortages etc. Any found should be reported to your CLARKE dealer where the appliance was originally purchased. This CON850 Reciprocating Saw is supplied with the following components:

- 1 x Reciprocating Saw
- 3 x Saw Blades (L=130mm) for cutting wood (other blade lengths available)
- 3 x Saw Blades (L=80mm) for cutting metal (other blade lengths available)
- 1 x Storage Case
- 1 x Instruction Manual (this document)

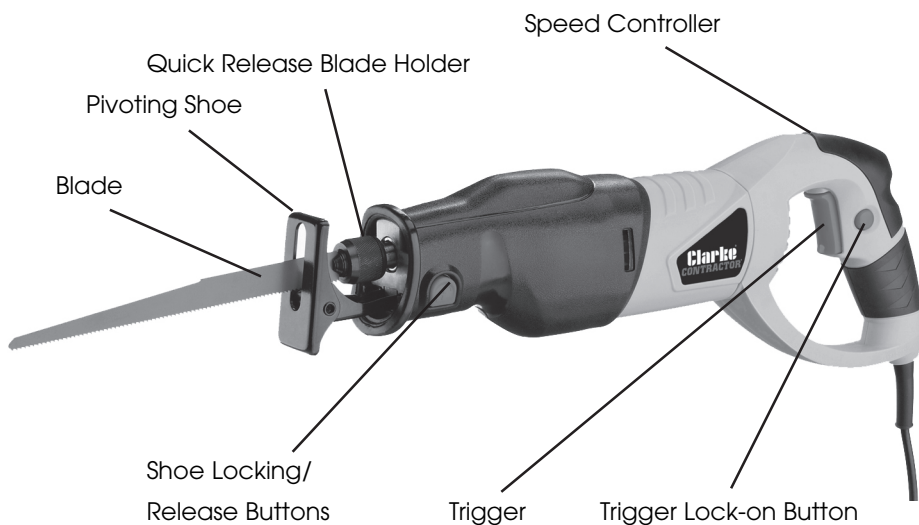



## BEFORE USE



CAUTION: USE ONLY RECIPROCATING SAW BLADES WITH THE CORRECT FITTING AS SHOWN IN FIG 1.

ALWAYS ENSURE THE SAW IS DISCONNECTED FROM THE POWER SUPPLY BEFORE INSTALLING/REMOVING THE BLADE.

### INSTALLING/CHANGING BLADES

1. Hold the reciprocating saw as shown in fig 2.
2. Twist the blade holder and insert or remove the blade while keeping the bladeholder open.
  - Never use cracked, blunt or otherwise damaged blades.
3. Release the blade holder when the blade is in position. The blade will now be locked in place.
4. Pull the blade to check that it is secure. If it will not pull out, it is correctly fitted.

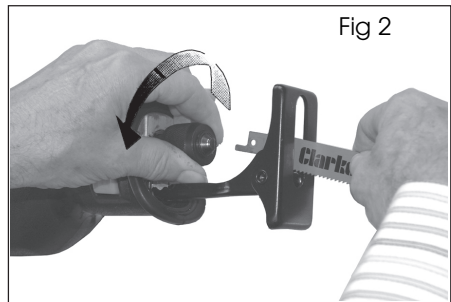
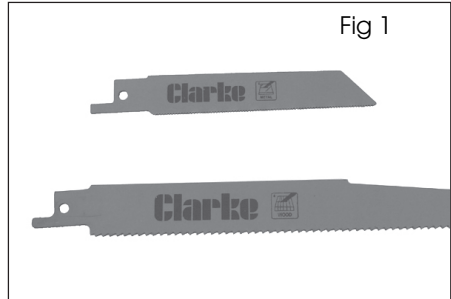

### ADJUSTING THE SHOE



CAUTION: ALWAYS ENSURE THE SAW IS DISCONNECTED FROM THE POWER SUPPLY BEFORE MAKING ADJUSTMENTS.

To adjust the shoe, unlock by pressing the locking button on the left side of the saw. Adjust the shoe to the desired position and then push the locking button on the right hand side back in to secure the shoe in position.

- Note that the shoe can slide fully in and out of the saw body.

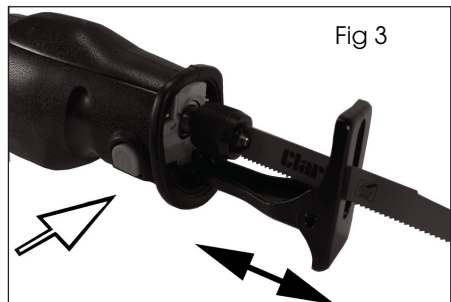

---

# OPERATION

---

**IMPORTANT: DO NOT plug in to the mains, unless you have ensured the saw is switched OFF. To do this, squeeze the trigger fully, then release it.**

## PRIOR TO CUTTING

1. Ensure that the workpiece is securely held in place and that the cut line is clearly marked.
2. Ensure the blade is not striking on anything below the workpiece and that the power cable is well away from the moving blade before starting the saw.
  - Let the blade work naturally. If cutting out an aperture, it will be necessary to drill a suitably sized hole in the workpiece for use as a starting point.
  - The blade should emerge from the workpiece at every point of the cut.
3. Check that any previously used timber being sawn does not contain any nails or other metal objects which would damage the blade.

## STARTING & STOPPING

1. To start the saw, squeeze the trigger.
2. Maintain the saw at a constant speed by pressing in the lock button.
  - You can then release your finger pressure on the trigger.
3. To stop the saw if the lock button is used, squeeze the trigger fully in, then release it and the motor will stop. Always switch off before unplugging.

## USING THE SAW

---



CAUTION: ALWAYS KEEP YOUR HANDS AND FINGERS AWAY FROM THE SHOE LOCKING BUTTON WHEN USING YOUR SAW. DEPRESSING THE LOCK BUTTON DURING USE MAY RESULT IN THE SHOE BECOMING UNLOCKED AND MOVING DURING USE.

---

1. Place the shoe against the workpiece and squeeze the trigger to run the saw before letting the blade touch the cut line on the work. To make your cut, move the saw slowly forward along the cutting line.
2. Take care not to allow the saw to bounce on the workpiece. Ensure the shoe remains in contact with the workpiece.
3. **Always hold the saw with both hands on the body and handle.**

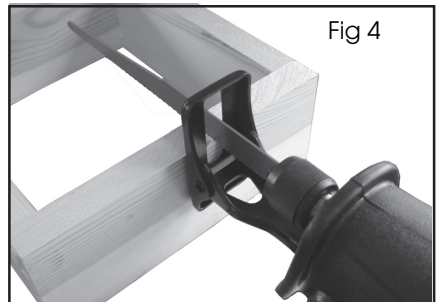

4. Take extra care when cutting curves - move slowly to avoid stress on the blade.
5. Avoid putting unnecessary pressure on the blade and avoid applying lateral pressure. Let the blade work naturally.
6. Never try to start the tool if the blade becomes jammed in the workpiece.
7. If the blade becomes blunt in one section of its cutting edge, reposition the shoe to utilise a sharper, unused portion of the blade. Fig 3 shows the adjustable shoe which can be positioned close to the blade holder and then extended to optimise the use of the blades & extend their useful life.

## CUTTING DIFFERENT MATERIALS

Adjust the speed controller to suit the material being cut using the following suggested settings as a starting point. However, the optimum speed will be determined with practice.

Plastic	1 - 3
Steel	2 - 4
Hardboard	3 - 4
Ceramics, aluminium	3 - 6 (max)
Wood	4 - 6 (max)



### CUTTING WOOD

#### PLUNGE CUTTING IN WOOD

- Rest the saw shoe on the workpiece in such a position that the blade forms an appropriate angle for the plunge cut.
- Switch the tool on and slowly feed in the blade. Make sure that the saw shoe remains in contact with the workpiece at all times.

#### POCKET CUTS IN WOOD

- Measure and mark out the pocket cut. Using a narrow blade, rest the bottom of the shoe on the workpiece ensuring the blade is on the cutting line. If necessary, e.g. in confined spaces, use the outer edge of the saw shoe as your guideline.

### CUTTING METAL

1. Choose the correct blade for cutting metal. Support the workpiece with wooden blocks on either side.
2. Apply a thin film of lubricant along the cutting line to prevent the tool from overheating.

### CUTTING PLASTICS

- Always work at reduced speed and carry out a test cut to see if the material is sensitive to heat.

## FAULT FINDING

Problem	Possible Cause	Remedy
Tool will not operate.	No power supply.	Check supply and rectify.
	Switch is faulty.	Consult your Clarke dealer.
	Fuse blown.	Check and replace.
	Motor is faulty.	Consult your Clarke dealer.
Motor becomes hot.	Unduly heavy use.	Reduce the force applied to the tool. Let the tool do the work.
	Air vents have become blocked.	Clean out the air vents using compressed air or clean with a dry cloth.
	Low supply voltage.	Ensure supply voltage is correct. If an extension cable is used, ensure it is of the correct rating and is fully unwound.
Motor runs but blade does not move.	Blade fastening not tight	Secure blade.
	Drive gear broken.	Return to your Clarke dealer
Heavy internal sparking	Faulty motor.	Return to your Clarke dealer.
Excessive vibration.	Blade not mounted correctly.	Check and rectify.
	Machine bearings worn.	Return to your Clarke dealer.

## MAINTENANCE

### CLEANING

1. To ensure constant air circulation, always keep air vents clear of blockages, (use compressed air to clean the machine if possible).
2. After use, clean all dust and wood chippings from the reciprocating saw.
  - Clean all of the ventilation slots on the motor housing.
3. The blade holder should be kept clean and occasionally be lightly oiled.
4. Keep the handle clean and free from oil and grease.
5. Resin and glue on the blade causes poor cutting results. Clean the blade after use if necessary.

## GENERAL MAINTENANCE

1. Check the power cable to ensure it is sound and free from cracks, bare wires etc. Avoid using solvents when cleaning plastic parts, most plastics are susceptible to damage from the various types of commercial solvents.
2. Ensure all nuts, bolts and screws remain tight at all times.
  - All bearings etc, in this power tool are lubricated with a sufficient amount of high grade lubricant for the tools lifetime under normal operating conditions, therefore no further lubrication is required.
  - Only use the replacement blades specified for this product (consult your CLARKE dealer).
  - Refer to your CLARKE dealer if internal maintenance is required.

---

## SPECIFICATION

---

Item	Specification
Weight	3.28 kg
Dimensions (L x W x H)	508 x 80 x 130 mm
Voltage	230V / 50 Hz
Fuse Rating	13 A
Motor Power	850 W
Speed Control Type	Variable
No-load Speed	800 - 3000 strokes/min
Length of Stroke	24 mm
Max Cutting Capacity	Wood: 210, Mild Steel: 10, Aluminium: 20 mm
Sound pressure Level	88 dB LpA
Guaranteed Sound Power Level	99 dB LWA
Vibration	14 m/s <sup>2</sup>
Uncertainty Factor	1.5 m/s <sup>2</sup>

Please note that the details and specifications contained herein, are correct at the time of going to print. However, CLARKE International reserve the right to change specifications at any time without prior notice.

# PARTS DIAGRAM

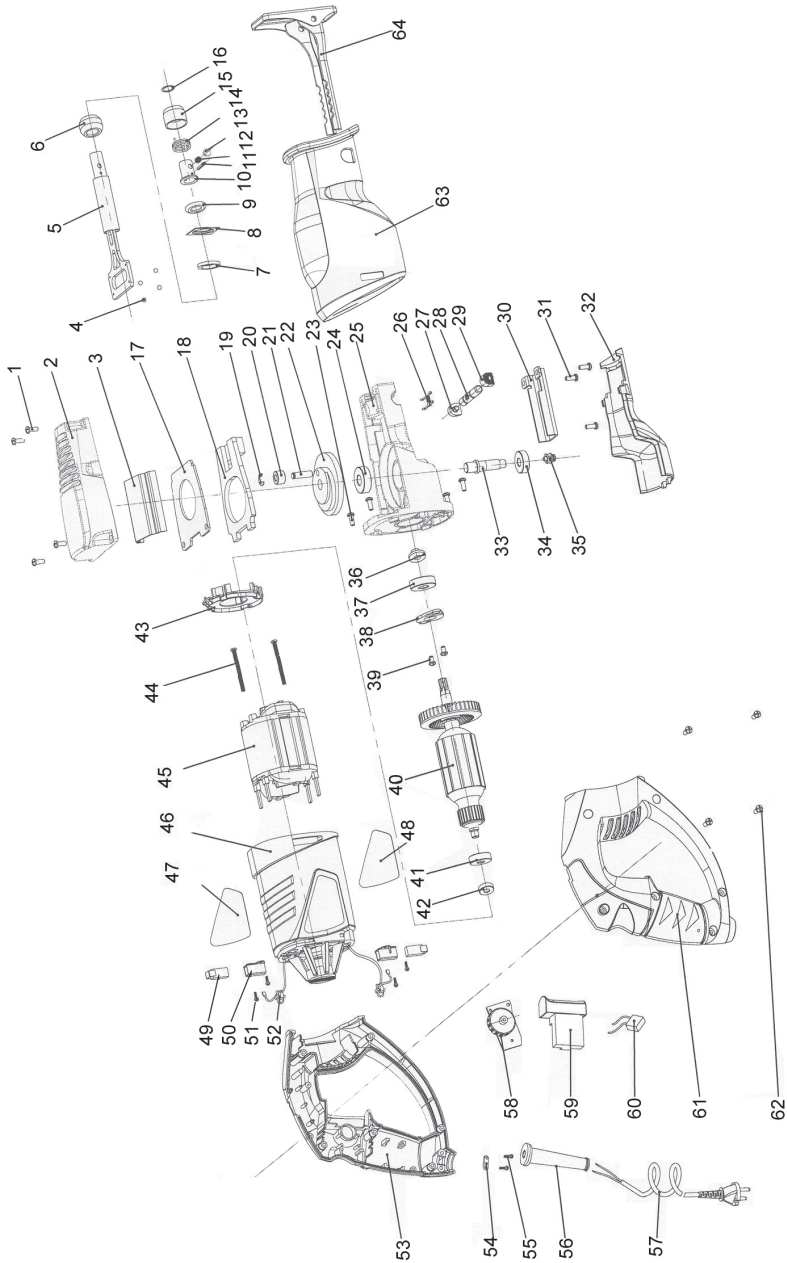

## PARTS LIST

No	Part No	Description
1	HTCON85001	Screw
2	HTCON85002	Gearbox Cover
3	HTCON85003	Alignment Plate
4	HTCON85004	Steel Ball
5	HTCON85005	Reciprocating Shaft
6	HTCON85006	Ball Bearing
7	HTCON85007	Sealing Ring
8	HTCON85008	Washer
9	HTCON85009	O-Ring
10	HTCON85010	Inner Collet
11	HTCON85011	Roll Pin (3 x 16)
12	HTCON85012	Spring
13	HTCON85013	Pin
14	HTCON85014	Spring
15	HTCON85015	Outer Collet
16	HTCON85016	O-Ring
17	HTCON85017	Gear Plate
18	HTCON85018	Balance Block
19	HTCON85019	Circlip
20	HTCON85020	Needle Brg K061208
21	HTCON85021	Pin
22	HTCON85022	Gear
23	HTCON85023	Screw
24	HTCON85024	Ball Bearing 6000

No	Part No	Description
25	HTCON85025	Gear Housing
26	HTCON85026	Spring
27	HTCON85027	Left Button
28	HTCON85028	Pin
29	HTCON85029	Right Button
30	HTCON85030	Retaining Plate
31	HTCON85031	Screw M5 x 10
32	HTCON85032	Plastic Protector
33	HTCON85033	Gear Spindle
34	HTCON85034	Ball Bearing 608
35	HTCON85035	Screw M5 x 14
36	HTCON85036	Dust Seal
37	HTCON85037	Ball Bearing 6000
38	HTCON85038	Compression Disc
39	HTCON85039	Screw M4 x 8
40	HTCON85040	Rotor
41	HTCON85041	Ball Bearing 607
42	HTCON85042	Bearing Sleeve
43	HTCON85043	End Plate
44	HTCON85044	Screw st4.2 x 65
45	HTCON85045	Motor Stator
46	HTCON85046	Housing
47	HTCON85047	Label (L/H)
48	HTCON85048	Label (R/H)

## PARTS LIST

No	Part No	Description
49	HTCON85049	Brush
50	HTCON85050	Brush Holder
51	HTCON85051	Screw
52	HTCON85052	Inductor
53	HTCON85053	Handle (LH)
54	HTCON85054	Cable Clamp
55	HTCON85055	Screw
56	HTCON85056	Cable Guard

No	Part No	Description
57	HTCON85057	Power Cable & Plug
58	HTCON85058	Speed Controller
59	HTCON85059	Trigger
60	HTCON85060	Capacitor 0.22 mF
61	HTCON85061	Handle (RH)
62	HTCON85062	Screw st 4.2 x 16
63	HTCON85063	Rubber Sleeve
64	HTCON85064	Support Shoe

## CONSUMABLE SPARE PARTS

Replacement saw blades for wood and metal are available from your CLARKE dealer.

Replacement Blades (5 per pack)

- Logs/rough wood:- Part no: 6462027
- Prepared timber:- Part No: 6462028
- Metal:- Part no: 6462029



---

# VIBRATION EMISSIONS

---

## HAND-ARM VIBRATION

*Employers are advised to refer to the HSE publication "Guide for Employers".*

All hand held power tools vibrate to some extent, and this vibration is transmitted to the operator via the handle, or hand used to steady the tool. Vibration from about 2 to 1500 hertz is potentially damaging and is most hazardous in the range from about 5 to 20 hertz.

Operators who are regularly exposed to vibration may suffer from Hand Arm Vibration Syndrome (HAVS), which includes 'dead hand', 'dead finger', and 'white finger'. These are painful conditions and are widespread in industries where vibrating tools are used.

The health risk depends upon the vibration level and the length of time of exposure to it.....in effect, a daily vibration dose.

Tools are tested using specialised equipment, to approximate the vibration level generated under normal, acceptable operating conditions for the tool in question. For example, a grinder used at 45° on mild steel plate, or a sander on softwood in a horizontal plane etc.

These tests produce a value 'a', expressed in metres per second per second, which represents the average vibration level of all tests taken, in three axes where necessary, and a second figure 'K', which represents the uncertainty factor, i.e. a value in excess of 'a', to which the tool could vibrate under normal conditions. These values appear in the specification panel below.

MODEL No:	<b>CON850</b>
DESCRIPTION:	<b>RECIPROCATING SAW</b>
Declared vibration emission value in accordance with EN12096	
Measured vibration emission value - $a$ : 14 m/s <sup>2</sup>	
Uncertainty value - $K$ : 1.5 m/s <sup>2</sup>	
Values determined according to EN28622-1	

You will note that a third value is given in the specification - the highest measured reading in a single plane. This is the maximum level of vibration measured during testing in one of the axes, and this should also be taken into account when making a risk assessment.

'a' values in excess of 2.5 m/s<sup>2</sup> are considered hazardous when used for prolonged periods. A tool with a vibration value of 2.8 m/s<sup>2</sup> may be used for up to 8 hours (cumulative) per day, whereas a tool with a value of 11.2 m/s<sup>2</sup> may be used for ½ hour per day only.

The graph below shows the vibration value against the maximum time the respective tool may be used, per day.

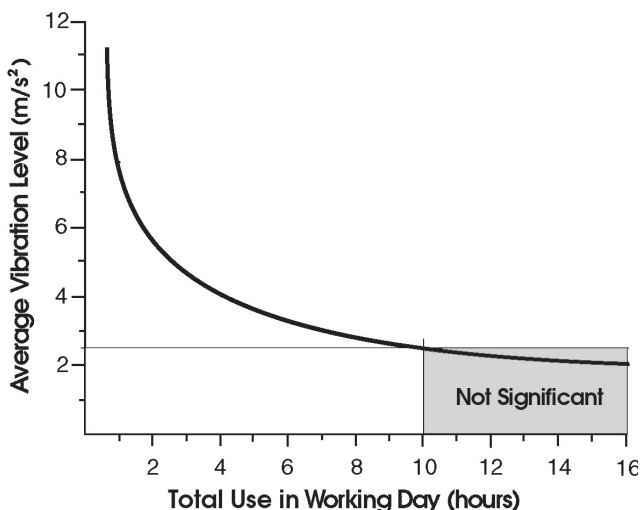

The uncertainty factor should also be taken into account when assessing a risk. The two figures 'a' and 'K' may be added together and the resultant value used to assess the risk.

It should be noted that if a tool is used under abnormal, or unusual conditions, then the vibration level could possibly increase significantly. Users must always take this into account and make their own risk assessment, using the graph above as a reference.

Some tools with a high vibration value, such as impact wrenches, are generally used for a few seconds at a time, therefore the cumulative time may only be in the order of a few minutes per day. Nevertheless, the cumulative effect, particularly when added to that of other hand held power tools that may be used, must always be taken into account when the total daily dose rate is determined.

# DECLARATION OF CONFORMITY



**Clarke**<sup>®</sup>  
**INTERNATIONAL**

Hemnoll Street, Epping, Essex CM16 4LG

## DECLARATION OF CONFORMITY

This is an important document and should be retained.

We hereby declare that this product(s) complies with the following directive(s):

- 2004/108/EC *Electromagnetic Compatibility Directive.*
- 2006/42/EC *Machinery Directive.*
- 2006/95/EC *Low Voltage Equipment Directive.*
- 2002/95/EC *Restriction of Hazardous substances.*

The following standards have been applied to the product(s):

- EN 60745-1:2009, EN 60745-2-11:2003+A11+A1+A12, EN 61000-3-2:2000+A2,
- EN 61000-3-3:1995+A1+A2, EN 55014-1:2006, EN 55014-2:1997+A1:2001.

The technical documentation required to demonstrate that the product(s) meet(s) the requirement(s) of the aforementioned directive(s) has been compiled and is available for inspection by the relevant enforcement authorities.

The CE mark was first applied in: 2008

**Product Description:** Reciprocating Saw (850W)  
**Model number(s):** CON850  
**Serial / batch Number:** N/A  
**Date of Issue:** 04/01/2011

Signed:



.....

J.A. Clarke  
Director

# A SELECTION FROM THE VAST RANGE OF

# Clarke®

## QUALITY PRODUCTS

### AIR COMPRESSORS

From DIY to industrial, Plus air tools, spray guns and accessories.

### GENERATORS

Prime duty or emergency standby for business, home and leisure.

### POWER WASHERS

Hot and cold, electric and engine driven - we have what you need

### WELDERS

Mig, Arc, Tig and Spot. From DIY to auto/industrial.

### METALWORKING

Drills, grinders and saws for DIY and professional use.

### WOODWORKING

Saws, sanders, lathes, mortisers and dust extraction.

### HYDRAULICS

Cranes, body repair kits, transmission jacks for all types of workshop use.

### WATER PUMPS

Submersible, electric and engine driven for DIY, agriculture and industry.

### POWER TOOLS

Angle grinders, cordless drill sets, saws and sanders.

### STARTERS/CHARGERS

All sizes for car and commercial use.



**PARTS & SERVICE: 020 8988 7400**  
E-mail: [Parts@clarkeinternational.com](mailto:Parts@clarkeinternational.com) or [Service@clarkeinternational.com](mailto:Service@clarkeinternational.com)

**SALES: UK 01992 565333 or Export 00 44 (0)1992 565335**

**Clarke®** INTERNATIONAL Hemnall Street, Epping, Essex CM16 4LG  
[www.clarkeinternational.com](http://www.clarkeinternational.com)