

Blamke® STRONG-ARM



HYDRAULIC PALLET TRUCK

MODEL No: PTE550

PART Nos 7630171

OPERATION & MAINTENANCE INSTRUCTIONS



0604



Please read these instructions carefully before operating the truck

Thank you for purchasing this **CLARKE** Pallet Truck.
Before using the device, please read this manual thoroughly and carefully follow all instructions given. This is for your own safety and that of others around you, and is also to help you achieve a long and trouble free service from your new truck.

CLARKE GUARANTEE

This CLARKE product is guaranteed against faulty manufacture for a period of 12 months from the date of purchase. Please keep your receipt as proof of purchase.

This guarantee is invalid if the product is found to have been abused or tampered with in any way, or not used for the purpose for which it was intended.

Faulty goods should be returned to their place of purchase, no product can be returned to us without prior permission.

This guarantee does not affect your statutory rights.

PARTS & SERVICE TEL: 020 8988 7400

or e-mail as follows:

PARTS: Parts@clarkeinternational.com

SERVICE: Service@clarkeinternational.com

CONTENTS

Guarantee	2
Contents	3
Specifications	4
Safety Precautions	5
Assembly	6/7
Operating Instructions	7/8
Maintenance	8
Parts Diagram	9
Parts List	10/11
Fault Finding	12
Declaration Of Conformity	13

FEATURES

- 3 Position trigger includes neutral for safe handling.
- Adjustable descent speed control.
- Chrome plated piston, ensuring a longer life.
- Drop forged lift link arms provide strength and durability.

Clarke[®]
INTERNATIONAL

SPECIFICATIONS

Model	PTE550
Part Number	7630171
Lifting capacity	2,000 kg
Overall Width	550mm
Fork Length	1100mm
Fork Width	150mm
Gap Between Forks	250mm
Fork Height (Lowered)	75mm
Fork Height (Raised)	190mm
Entry Options	4 Way
Fork Rollers	Single Nylon
Finish	Red Powder Coat
Weight	56 kg

WARNING!
MAXIMUM LOAD - 2000KG

Please note that the details and specifications contained herein are correct at the time of going to print. However CLARKE International reserve the right to change specifications at any time without prior notice. Always consult the machines data plate

SAFETY PRECAUTIONS

- **ALWAYS** wear good quality safety shoes, (steel toe caps) and industrial work gloves.
- **ALWAYS** ensure the load is evenly distributed on the forks and is perfectly stable before attempting to raise.
- **ALWAYS** before operating, ensure that all bolts, pins and securing devices are correctly in place and in good condition. Check for signs of cracked welds, bent or loose pins or other signs of structural damage. Do not use if any of these conditions exist. Ensure repairs are carried out by qualified persons only, or contact your nearest Clarke dealer.
- **ALWAYS** lower the forks to their lowest position when not in use,, and ensure it is left where it cannot become a hazard to others. If necessary, the wheels must be chocked to prevent it from moving and possibly becoming a hazard.
- **ALWAYS** ensure the machine is properly maintained at all times (see Maintenance).
- **NEVER** turn the tiller at right handles to stop the truck.
- **NEVER** exceed the load for which the machine was designed. If the load capacity and other warning labels become defaced or illegible, have them replaced.
- **NEVER** use the truck to transport persons, or use as a scooter.
- **NEVER** use in applications where a risk exceeding the rated capacity exists.
- **NEVER** use in applications where a risk of unintentional movement exists.
- **NEVER** allow the truck to have direct contact with foodstuffs.
- **NEVER** use truck in potentially explosive atmosphere.
- **DO NOT** leave load on pallet truck for lengthy periods
- **DO NOT** rapid load the truck, i.e.; drop heavy loads directly onto forks.
- **DO NOT** allow any person to operate the machine unless they are completely familiar with all aspects of operation and have read this manual thoroughly.
- **DO NOT** use as a vehicle jack
- **DO NOT** use the extremity of fork arms as a lever to lift a load.
- **DO NOT** exceed the maximum working load for the truck. See Specifications.
- **DO NOT** use on gradients due to excessive efforts and loss of control.
- **DO NOT** use on rough terrain, floor requirements are, smooth, non slip, hard, level and without obstacles ONLY.
- **DO NOT** transport personnel on the truck, or use as a scooter.
- **DO NOT** leave the truck on a gradient without first securely chocking the wheels.
- **DO NOT** use if wheels or castors are damaged...have them replaced immediately.
- **DO NOT** use in places insufficiently illuminated, (min 50 lux).
- If the machine has been subjected to an abnormal load or shock, remove it from service immediately and have it fully inspected by a qualified person. If necessary, consult your Clarke dealer.
- The truck must not be altered or modified in any way.

IMPORTANT:

ALWAYS check to ensure the centre of gravity of the load is centered about the forks.

ASSEMBLY Figures in brackets refer to Index Nos in parts list on pages 9-12

Your new Pallet truck is delivered with the handle removed, To fit the handle proceed as follows;

1. Remove one roll pin, item 1, Fig. 1 (24) from shaft, item 2, Fig. 1 (23) and keep safe for reuse later.
2. Remove shaft from pump body item 4, Fig. 2.
3. Insert Handle tube with warning label on top and trigger on R/H side, item 3, Fig.2 (8) at position A, Fig. 1, **Note ; handle needs to be held at an angle of approx 45° in order to fit the shaft**, connect handle tube to pump body by sliding the shaft, item 2, Fig. 1, back into pump body and handle tube.
4. Turn shaft so that the roll pin is vertical. **DO NOT** push fully home yet.
5. Pass the roller chain, item 5, Fig. 2 (10), through the centre hole in shaft, Locate nut into slot of lever plate, item 6, Fig. 2 (52).
6. Turn shaft so that roll pin lines up with slots in pump body, push shaft fully home and refit roll pin removed earlier, this secures handle in place.
7. Push handle down into a horizontal position, see Fig. 4, and withdraw pin item 7, Fig. 4. Store pin in safe place for use should truck require to be dismantled again.

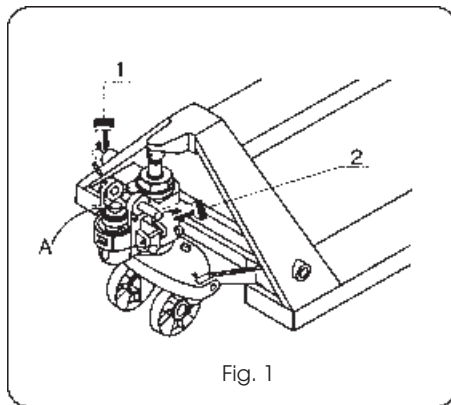

Fig. 1

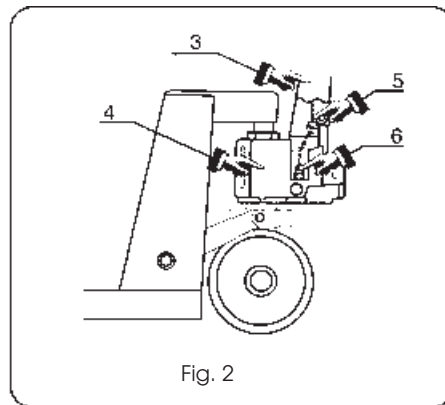

Fig. 2

8. Raise the forks by pushing the trigger, item 8, Fig. 3 down until it latches. Pump handle backwards and forwards, forks should lift. and should remain in up position.
If forks drop without raising the trigger up to the lowering position, proceed as follows.
 - a) Loosen locknut, item 10, Fig. 5 (53) and turn screw, item 9, Fig. 5 (54) anticlockwise one full turn, tighten locknut.
 - b) Repeat steps 8 & 8a again if forks continue to drop, turn screw another full turn, keep repeating this procedure until forks stay up until, the trigger is operated to lower the truck. If forks do not lower when operating the trigger, turn the screw clockwise, test and repeat until it does.
 - c) When satisfied the truck is lifting and raising properly, tighten the locknut item 10, Fig.5.

WARNING!
MAXIMUM LOAD - 2000KG

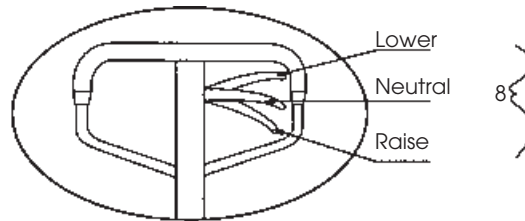

Fig. 3

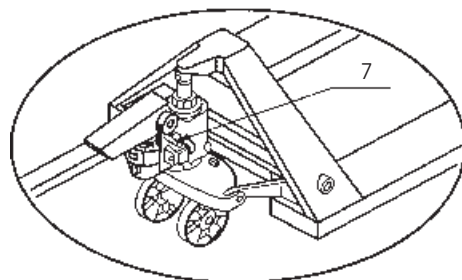

Fig. 4

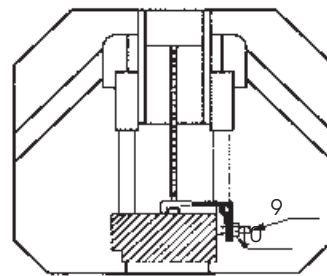

Fig. 5

OPERATING INSTRUCTIONS

Before operating the truck, ensure you have read and understood the instructions in this manual, paying particular attention to the safety precautions.

Familiarise yourself with the controls, i.e; raise and lower the forks without any load, practice steering the empty truck to understand how the truck reacts.

To raise the forks, push the trigger down until it latches, then slowly pump the handle backwards and forwards and watch the forks lift, once the forks are in their highest position, put the trigger into the central position (neutral), to lower the forks, gently pull the trigger upwards, or push the foot pedal down the more the trigger is pulled up or the foot pedal is pushed down, the faster the forks will lower,

NOTE:

The forks will drop much faster when a load is on the forks, also the heavier the load the faster still the rate of descent.

1. Ensure the pallet to be moved does not exceed the maximum weight for the truck.
2. Make visual checks to ensure the load is secure and will not topple off when lifted, also check the pallet is not broken etc.
3. Once satisfied all is ok, proceed as follows.
 - a) With the forks in their lowest position, Slowly push the truck under the load to be moved, try to position the truck so that the centre of gravity is in the middle of the forks. In the event this is not possible the rated capacity is reduced, ie; the truck is designed and built to lift a maximum load of 2000 kg spread over both forks. Take care that the fork rollers are not sitting on any pallet cross member etc.

- b) Slowly raise the forks and watch the load lift, once the load has been raised sufficiently, put the trigger in the neutral position (centre), before attempting to move the truck.
- c) Gently push or pull the pallet truck with load to its new location, observing that there are no personnel or obstacles in the way.
- d) Before lowering the load, ensure it is clear to do so, i.e.; make sure that nobody's feet, including your own are underneath the pallet etc, once satisfied the way is clear, slowly lower the load to the floor.
- e) Withdraw the pallet truck, Lower the forks to their lowest position and store safely so as not to cause an obstruction, chock the wheels if necessary to prevent the truck moving accidentally.

NOTE:

If the truck has not been used for some time, there is a possibility that the hydraulic system may have absorbed air.

This can easily be removed in the following way:

- 1. With the trigger pulled up fully (lowering position), quickly pump the handle backwards and forwards 4 - 6 times.***
- 2. Push trigger down to its lowest position, slowly pump the handle backwards and forwards, forks should now lift, if not repeat steps 1 & 2 until the forks lift normally.***

MAINTENANCE

Inspect the truck daily for possible cracks/damage, also check for oil leaks. Special attention should be paid to the nylon wheels. Check that all wheels and auxiliary rollers are complete and turn freely, check they are not blocked by anything being wrapped around the axles, i.e.; threads and rags etc, if any are found they should be removed. Nuts and bolts etc, if run over can and do get embedded in the nylon wheels, if any such foreign objects are found, they should be removed.

Approx every three months all moveable joints should be lubricated using a good quality motor oil, DO NOT apply so much oil that it drips onto the floor.

WARNING!
MAXIMUM LOAD - 2000KG

PARTS DIAGRAM

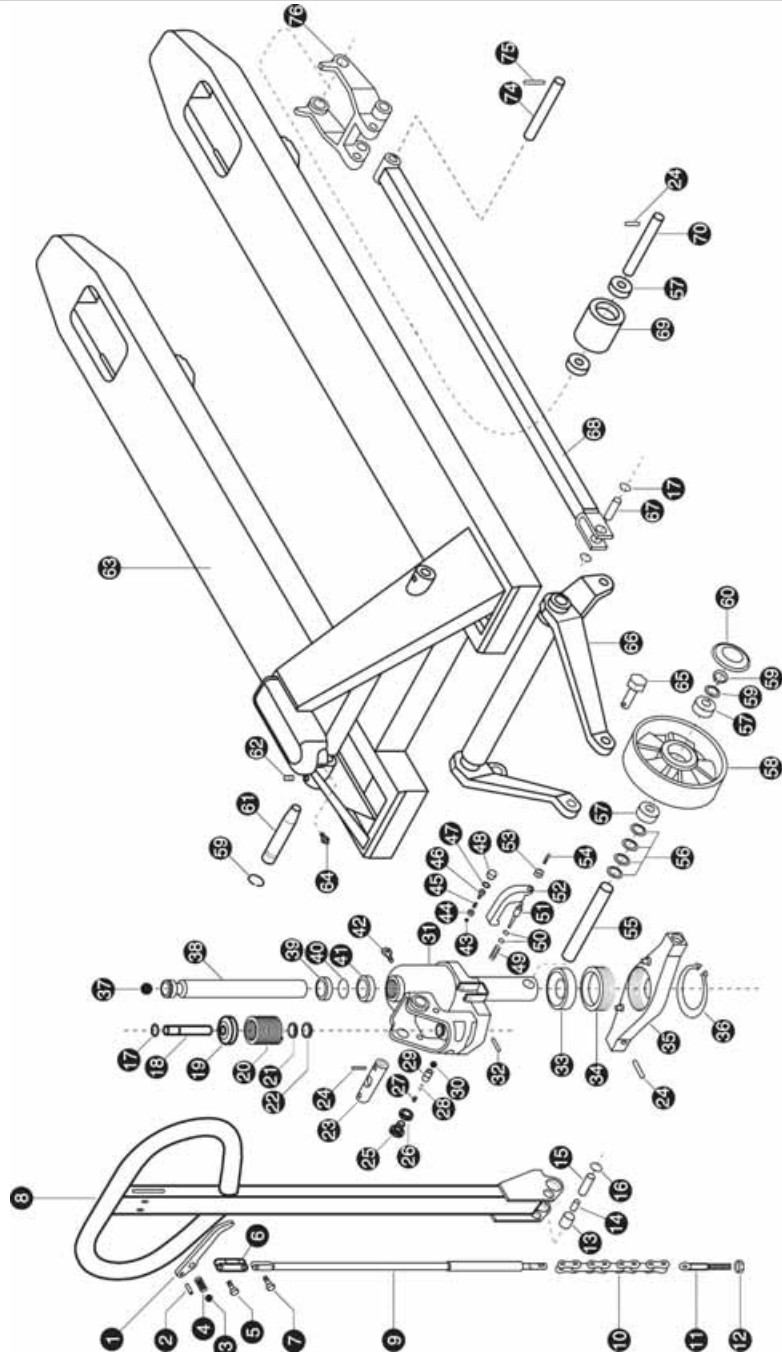

PARTS LIST

Index No	Part No	Description	Qty
1	ZJPE55001	Lever	1
2	ZJPE55002	Roll Pin 6 x 26	1
3	ZJPE55003	Steel Ball	2
4	ZJPE55004	Spring	1
5	ZJPE55005	Rivet	1
6	ZJPE55006	Link	1
7	ZJPE55007	Rivet	1
8	ZJPE55008	Handle	1
9	ZJPE55009	Pull Shaft	1
10	ZJPE55010	Chain	1
11	ZJPE55011	Adjusting Screw	1
12	ZJPE55012	Lock Nut	1
13	ZJPE55013	Pressure Roller	1
14	ZJPE55014	Bush	1
15	ZJPE55015	Pin	1
16	ZJPE55016	Retaining Ring	1
17	ZJPE55017	Retaining Ring	5
18	ZJPE55018	Plunger	1
19	ZJPE55019	Cover	1
20	ZJPE55020	Spring	1
21	ZJPE55021	Dust Ring	1
22	ZJPE55022	'Y' Ring	1
23	ZJPE55023	Shaft	1
24	ZJPE55024	Roll Pin	10
25	ZJPE55025	Plug	1
26	ZJPE55026	Copper Washer	1
27	ZJPE55027	Spring	1
28	ZJPE55028	Damping Valve Spindle	1
29	ZJPE55029	Damping Valve Seat	1
30	ZJPE55030	Steel Ball	1
31	ZJPE55031	Base	1
32	ZJPE55032	Roll Pin	1
33	ZJPE55033	Bowl Washer	1

IMPORTANT:

The use of parts other than CLARKE replacement parts may result in safety hazards, decreased tool performance and may invalidate your warranty.

PARTS LIST

Index No	Part No	Description	Qty
34	ZJPTE55034	Bearing	1
35	ZJPTE55035	Supporting Base	1
36	ZJPTE55036	Retaining Ring	1
37	ZJPTE55037	Steel Ball	1
38	ZJPTE55038	Piston	1
39	ZJPTE55039	Dust Ring	1
40	ZJPTE55040	`O` Ring	1
41	ZJPTE55041	`Y` Ring	1
42	ZJPTE55042	Oil Plug	1
43	ZJPTE55043	Steel Ball	1
44	ZJPTE55044	Base	1
45	ZJPTE55045	Spring	1
46	ZJPTE55046	Regulation Screw	1
47	ZJPTE55047	Copper Washer	1
48	ZJPTE55048	Plug	1
49	ZJPTE55049	Spring	1
50	ZJPTE55050	`O` Ring	2
51	ZJPTE55051	Strike Pin	1
52	ZJPTE55052	Lever Plate	1
53	ZJPTE55053	Lock Nut	1
54	ZJPTE55054	Regulation Screw	1
55	ZJPTE55055	Big Wheel Shaft	1
56	ZJPTE55056	Washer	10
57	ZJPTE55057	Bearing	12
58	ZJPTE55058	Big Wheel (Nylon)	2
59	ZJPTE55059	Retaining Ring	4
60	ZJPTE55060	Dust Cover	2
61	ZJPTE55061	Shaft	2
62	ZJPTE55062	Bolt	2
63	ZJPTE55063	Fork Frame	1
64	ZJPTE55064	Bolt	1
65	ZJPTE55065	Pin	2
66	ZJPTE55066	Rocker Arm	1
67	ZJPTE55067	Pin	2
68	ZJPTE55068	Straight Tappet	2
69	ZJPTE55069	Fork Wheel (Nylon)	2
70	ZJPTE55070	Shaft	2

TROUBLE SHOOTING

No.	Symptoms	Possible Causes	Remedy
1.	Forks not lifting to maximum height.	Insufficient hydraulic oil.	Add more hydraulic oil.
2.	Forks not lifting.	a) No hydraulic oil. b) The oil is contaminated. c) The regulating screw (item 9) Fig.5 is set too close to strike pin.	a) Add Hydraulic oil. b) Change the hydraulic oil. c) Slacken locknut (item 10), turn the regulating screw a little ant- clockwise. Repeat adjustment until forks lift OK.
3.	The forks do not lower after raising.	a) The regulating screw set too far back from strike pin. b) Piston is deformed due to misuse, ie; overloading or loading to one side. c) The forks not lowered down fully when not in use, causing piston to rust.	a) Adjust regulating screw as above (turn screw clockwise). b) Fit new piston rod and cylinder. c) Clean and lubricate piston. Replace piston and cylinder if too badly damaged.
4.	Leaking oil.	a) Oil seals / 'O' rings worn or damaged. b) Pump body worn or cracked.	a) Replace. b) Replace.
5.	Forks drop without operating the trigger.	a) Contamination in the hydraulic oil. b) Leaking oil.	a) Wash the damping valve with kerosene and/or change the hydraulic oil. b) See above.

Clarke[®] INTERNATIONAL

This is an important document and should be retained

DECLARATION OF CONFORMITY



We declare that this product complies with the following standards/directives:

- 89/392/EEC
- EN 292-1
- EN 292-2
- B.S.4155
- GS - FL - 02/10.88 VGB 12A

Description: **PALLET TRUCK**

Model No: **PTE550**

Serial (Batch) No: **See Product Date Plate**

Signed: 
Service manager

Clarke[®] INTERNATIONAL
Hemnal Street, Epping, Essex CM16 4LG