

CLAMPRO®

POWER WASHER



WARNING Read the instructions before using the machine

PRESSURE WASHER

MODEL NO: JETSTAR 1750

PART NO: 7333230

OPERATION & MAINTENANCE INSTRUCTIONS



LS0711

INTRODUCTION

Thank you for purchasing this CLARKE pressure washer.

Before attempting to use this product, please read this manual thoroughly and follow the instructions carefully. In doing so you will ensure the safety of yourself and that of others around you, and you can look forward to your purchase giving you long and satisfactory service.

GUARANTEE

This product is guaranteed against faulty manufacture for a period of 12 months from the date of purchase. Please keep your receipt which will be required as proof of purchase.

This guarantee is invalid if the product is found to have been abused or tampered with in any way, or not used for the purpose for which it was intended.

Faulty goods should be returned to their place of purchase, no product can be returned to us without prior permission.

This guarantee does not effect your statutory rights.

SAFETY SYMBOLS

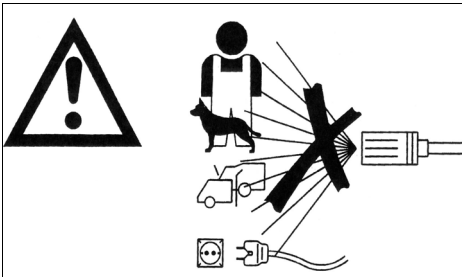

WARNING: Do not direct discharge stream at persons or animals. Keep clear of nozzle.

WARNING: Never direct spray toward any electrical device or electrical outlet.



General Warning, indicates that failing to follow these instruction could result in injury or damage to the machine.



To reduce the risk of injury, read the manual before use.



Wear safety glasses when using this machine.

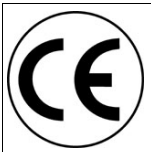

Conforms to CE Regulations.



Recycle unwanted materials instead of disposing of them as waste. All tools, accessories and packaging should be sorted, taken to a recycling centre and disposed of in a manner which is compatible with the environment.

GENERAL SAFETY RULES



WARNING: Water at high pressure can be dangerous and can cause damage if the operator is careless. Never allow anyone to operate this pressure washer unless they are familiar with the safety precautions.

1. **NEVER** direct the spray towards any person or animal.
2. **NEVER** direct the spray towards electrical wiring or equipment.
3. **NEVER** hold your finger over the high pressure nozzle.
4. **NEVER** allow children or untrained personnel to use this machine.
5. **NEVER** operate the machine with any of the covers removed.
6. **NEVER** attempt any repairs to this machine. Always refer to your Clarke dealer.
7. **NEVER** supply any liquid other than water to the water inlet.
8. **NEVER** use the detergent bottle to introduce flammable liquids/solvents, e.g. paint thinners, petrol, oil as there is a risk of explosion.
9. **ALWAYS** release any residual pressure in the system by turning off the water supply and operating the trigger before disconnecting any hose or accessory.
10. **ALWAYS** keep the machine itself dry and well clear of water spray.
11. **ALWAYS** wear protective clothing and safety glasses. Loose particles and other debris may be propelled at high speed by the water jet.
12. **ALWAYS** grip the gun firmly and expect the spray gun to 'kick' when starting.
13. **ALWAYS** respect the requirements of the local water company. Pressure washers may only be connected to the mains drinking water supply, if a system separator (also known as a backflow preventer) is installed in the supply hose.
14. **ALWAYS** disconnect from the water supply, and ensure the system is completely drained when not in use. Store in a cool dry location.
15. **ONLY** use chemical cleaning agents (detergents), that are approved for pressure washers. CLARKE Traffic Film Remover or CLARKE Wash and WAX (available from your dealer), is recommended.
16. **WARNING** High pressure water jets can be dangerous if subject to misuse. The jet must not be directed at person or anything that they are wearing.
17. **NEVER** direct the jet at electrical equipment or the machine itself.
18. **WARNING** High pressure hoses, fittings and couplings are important for the safety of the machine. Use only hoses, fittings and couplings recommended by the manufacturer.
19. **WARNING** Water that has flowed through a system separator (also known as a backflow preventer) is considered non-drinkable
20. **NEVER** use the pressure washer if the supply cable or important parts of the machine are damaged.

ELECTRICAL CONNECTIONS



WARNING! Read these electrical safety instructions thoroughly before connecting the product to the mains supply.

Before switching the product on, make sure that the voltage of your electricity supply is the same as that indicated on the rating plate. This product is designed to operate on 230VAC 50Hz. Connecting it to any other power source may cause damage.

This product may be fitted with a non-rewireable plug. If it is necessary to change the fuse in the plug, the fuse cover must be refitted. If the fuse cover becomes lost or damaged, the plug must not be used until a suitable replacement is obtained.

If the plug has to be changed because it is not suitable for your socket, or due to damage, it should be cut off and a replacement fitted, following the wiring instructions shown below. The old plug must be disposed of safely, as insertion into a mains socket could cause an electrical hazard.



**WARNING! The wires in the power cable of this product are coloured in accordance with the following code:
Blue = Neutral Brown = Live**

If the colours of the wires in the power cable of this product do not correspond with the markings on the terminals of your plug, proceed as follows.

- The wire which is coloured **Blue** must be connected to the terminal which is marked **N** or coloured **Black**.
- The wire which is coloured **Brown** must be connected to the terminal which is marked **L** or coloured **Red**.

Plug must be BS1363/A approved.

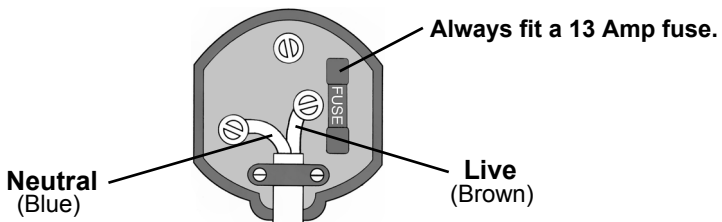

Ensure that the outer sheath of the cable is firmly held by the clamp

We strongly recommend that this machine is connected to the mains supply via a Residual Current Device (RCD)

If in any doubt, consult a qualified electrician. DO NOT attempt any repairs yourself.



This symbol indicates that this is a Class II product, and does not require an earth connection.

OVERVIEW



NO	DESCRIPTION	NO	DESCRIPTION
1	Handle	7	Car Brush
2	Lance Storage	8	Extension Lance
3	ON/OFF Switch	9	Spray Gun Assembly
4	Detergent Bottle and Nozzle	10	High Pressure Outlet Hose
5	Water Inlet	11	High Pressure Outlet (Rear of the unit)
5	Pressure Washer Lance		Nozzle Cleaning Tool (not shown)

UNPACKING AND ASSEMBLY

Unpack your pressure washer and check to ensure the following items are present.

Contact your Clarke dealer immediately if any parts are missing or damaged.

- 1 x Pressure Washer Assembly
- 1 x Detergent Bottle and Nozzle
- 1 x Gun Assembly
- 1 x Pressure Washer Lance
- 1 x Nozzle Cleaning Tool
- 1 x Operating Instructions
- 1 x Car Cleaning Brush



WARNING: DO NOT USE THE MACHINE IF A SUPPLY CORD OR IMPORTANT PARTS OF THE MACHINE ARE DAMAGED, E.G. SAFETY DEVICES, HIGH PRESSURE HOSES, TRIGGER GUN.

CONNECTING THE HIGH PRESSURE HOSE

1. Screw the high pressure hose onto the high pressure outlet.
2. Tighten the connector, hand tight only.
 - Do not use a spanner.

NOTE: Make sure the connection is secure.

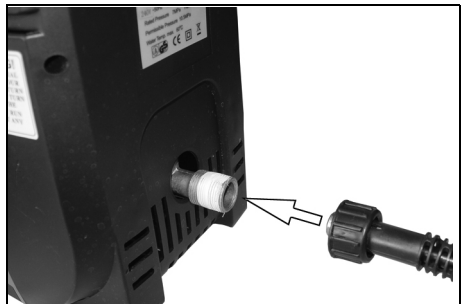

CONNECTING THE HIGH PRESSURE HOSE TO THE GUN ASSEMBLY

1. Screw the high pressure hose onto the gun assembly.
2. Use a spanner to tighten the connector.

NOTE: Make sure the connection is secure.



CONNECT WATER SOURCE

Always follow the regulations of your local water supplier. The pressure washer must never be used on the drinking water supply without using a system separator (also known as a backflow preventer).

NOTE: Water that has flowed through a system separator is considered non-drinkable.

1. Connect a water supply hose (not supplied) to the water inlet.

NOTE: Use a good quality fibre-reinforced water hose with a standard coupling (Minimum diameter 1/2 inch (13 mm)).

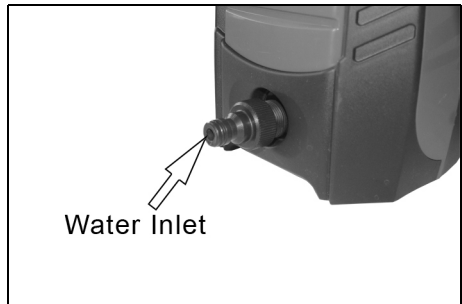

ATTACH THE SPRAY ACCESSORIES

1. Slide the spigot end of the spray accessory into the handle assembly.
2. Push in firmly and twist 90° to lock it into position.

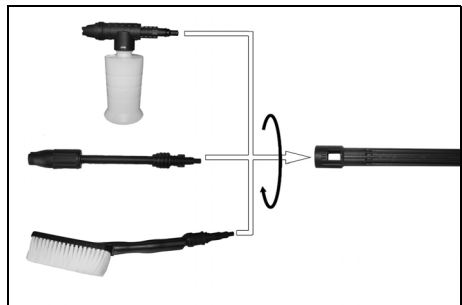

USING YOUR PRESSURE WASHER

1. Turn the water supply on, making sure that the tap is fully open.



WARNING: FAILURE TO TURN ON THE WATER COULD CAUSE DAMAGE TO THE PRESSURE WASHER.

2. Plug the mains power cable into the electricity supply.
3. Release the trigger lock.
 - Push the button from the other side if needed.

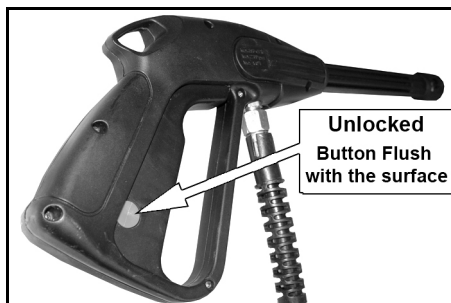

4. Press the section of the On/Off switch marked "I".
 - The pressure washer is now ready for use.
 - Make sure that you have a firm footing and are also holding the trigger gun and spray lance firmly. The lance and gun will kick back when in use.
5. Pull the trigger on the gun to start water flow.

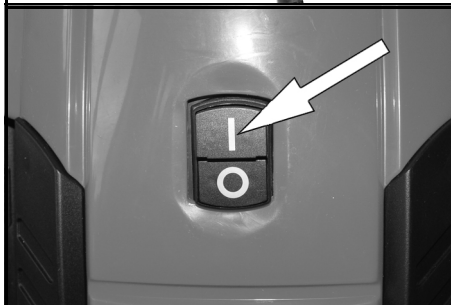

INTERRUPTING OPERATION

1. Release the lever on the trigger gun.
2. Engage the trigger lock.
 - The pressure washer is fitted with a total stop system to protect the motor when in use. When the trigger is released the motor will stop. When the trigger is squeezed the motor will start up again.
3. During longer breaks (more than 5 minutes), turn the appliance off See page 12.

ADJUSTING THE SPRAY

The nozzle is adjustable and allows you to adjust the spray from a narrow jet of water to a wide spray.

To adjust the nozzle, proceed as follows:

1. Hold the shaft of the pressure washer lance in one hand.
2. Twist the nozzle with the other hand.
3. The spray varies between narrow and wide as you turn the nozzle through 180° .



ADJUSTING THE PRESSURE

There are two ways to adjust the pressure of the water.

1. Back away from the surface being cleaned.
 - The further away you are the less the pressure will be on the surface being cleaned.
2. Adjust the spray to a wider angle.

APPLYING CHEMICALS AND CLEANING AGENTS

To improve the cleaning performance, You can introduce chemical cleaning agents (detergents) to the water jet using the detergent bottle and nozzle. This is particularly useful when washing cars, greasy engine parts, removing oil spots on concrete etc.

To prepare for detergent application,

1. Ensure the trigger lock is in the locked position, and the machine is switched OFF.
 - It is not necessary to pull the trigger to release the pressure.

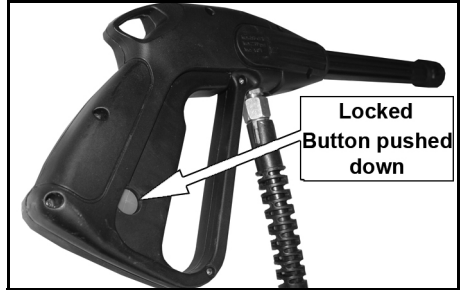

2. Connect the Detergent Bottle and Nozzle.

3. Unscrew the bottle from the nozzle and fill with the required detergent.

- Only use detergents recommended for use with pressure washers, such as CLARKE Traffic Film Remover which is a powerful low foaming agent for car cleaning, patio cleaning etc., or CLARKE Wash & Wax, both available from your CLARKE dealer.

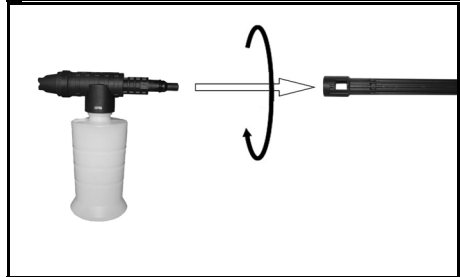

4. When the container is filled with detergent, screw it back on to the nozzle ensuring the plastic pick-up tube is in the fluid.
5. Switch ON the pressure washer, release the trigger lock and spray the detergent onto the vehicle, patio etc.
 - Allow the detergent a little time to work itself into the grime.
6. To rinse and clean, replace the Detergent Bottle and Nozzle with the Pressure Washer Lance.
7. After using the detergent bottle and nozzle, rinse the complete assembly (bottle and nozzle) thoroughly with clean water. (See Maintenance).



CAUTION: IF YOUR EYES COME INTO CONTACT WITH ANY CLEANING FLUIDS, RINSE THEM IMMEDIATELY WITH PLENTY OF FRESH CLEAN WATER, AND SEEK MEDICAL ADVICE IF REQUIRED.

SHUTTING DOWN

When you have finished using the pressure washer, follow the procedure shown below to switch off and disconnect the unit.

1. Press the section of the On/Off switch marked "O".
2. Turn off the water supply at the tap.
3. Release the pressure in the pump and hose by squeezing the trigger for a few seconds until no more water comes out of the nozzle.
4. Engage the trigger lock in the off position.
5. Disconnect from the mains power supply.

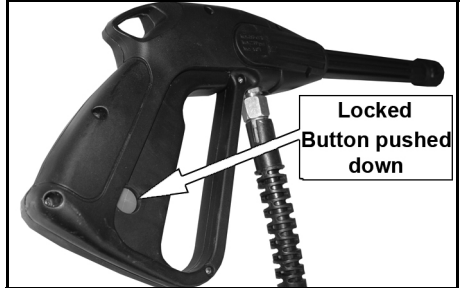
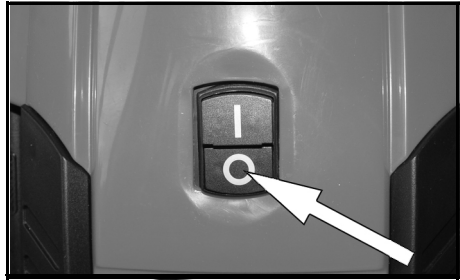

STORAGE

BEFORE STORING THE PRESSURE WASHER

1. Disconnect the high pressure hose and drain all water from the hose.
2. Coil the hose and store the gun/lance in the holder located on the side of the pressure washer.

STORAGE PROCEDURE

Make sure that the pressure washer has been thoroughly cleaned before storing it in a clean dry place. See "Maintenance" on page 13.

MAINTENANCE



WARNING: THE PRESSURE WASHER SHOULD BE DISCONNECTED FROM THE MAINS POWER SOCKET DURING CLEANING OR MAINTENANCE.

CLEANING THE NOZZLE

If the nozzle becomes clogged with foreign materials such as dirt or calcium, excessive pressure may develop. If the nozzle becomes partially clogged or restricted, the pump pressure will pulsate, clean the nozzle immediately by following the instructions below:

1. Turn off the pressure washer and turn off the water supply.
2. Pull trigger to release any water pressure in the hose.
3. Disconnect the lance from the gun.
4. Remove any obstructions with the nozzle cleaning tool provided.
5. Direct water from a tap into the end of the lance for 30 seconds to back flush loose particles.
6. Reconnect the lance to gun and turn on water supply.

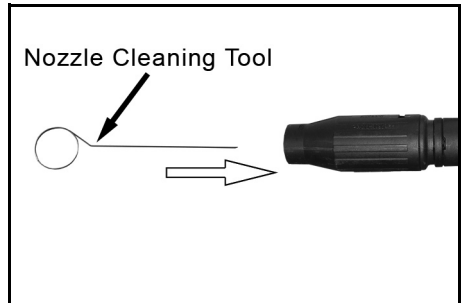

CLEANING THE WATER INLET FILTER

This filter should be checked periodically and cleaned if necessary.

1. Remove the inlet filter from the pressure washer as shown.
2. Clean the filter by flushing both sides with water.
3. Replace the filter into the water inlet.
 - Tapered side faces in.

NOTE: Do not operate the pressure washer without filter installed.

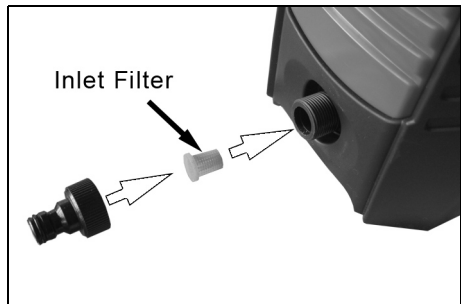

TROUBLESHOOTING

If the following does not solve your problem, please contact the CLARKE service department.

FAULT	CAUSE	SOLUTION
Pressure drop.	Air in system.	Bleed system by quickly operating trigger several times.
Pressure fluctuations or pressure drop.	Shortage of water.	Turn water tap on fully.
	Water supply hose too long/ too narrow.	Use a 1/2" diameter water supply hose.
	No water due to clogged inlet filter.	Clean water inlet filter.
Motor does not start when switched on.	Plug is not connected properly.	Check plug and lead and have them replaced by a qualified electrician if necessary.
	Mains fuse tripped/blown.	Renew fuse or reset.
Motor hums when trigger operated and does not start.	Mains voltage too low.	Have electrical connection checked.
	Pump seals stuck.	Contact your Clarke dealer.
Cleaning agents are not being supplied.	Container empty.	Fill container

ACCESSORIES

The range of accessories listed below may be purchased from your CLARKE dealer.

ITEM	PART NUMBER
5 Litres Detergent (Traffic Film Remover)	3050821
25 Litres Detergent (Traffic Film Remover)	3050820
5 Litres Wash 'n' Wax	3050815

SPECIFICATIONS

Model	JETSTAR 1750
Rated voltage	230/240V AC 50Hz
Input power	1600 W
Hose length	5 m
Protection Level	IPX5
WATER CONNECTION	
Max. feed temperature	40 °C
Max. feed pressure	0.3Mpa
PERFORMANCE DATA	
Maximum pump pressure	105 Bar
Water flow rate	5 l/min
Hand-arm vibration (ISO 5349)	Less than 2.5 m/s ²
Measured Sound Power Level	90 dB
Guaranteed Sound Power Level	93 dB
DIMENSIONS	
Length	270 mm
Width	235 mm
Height	410 mm
Weight	5 kg

EXPLODED DIAGRAM

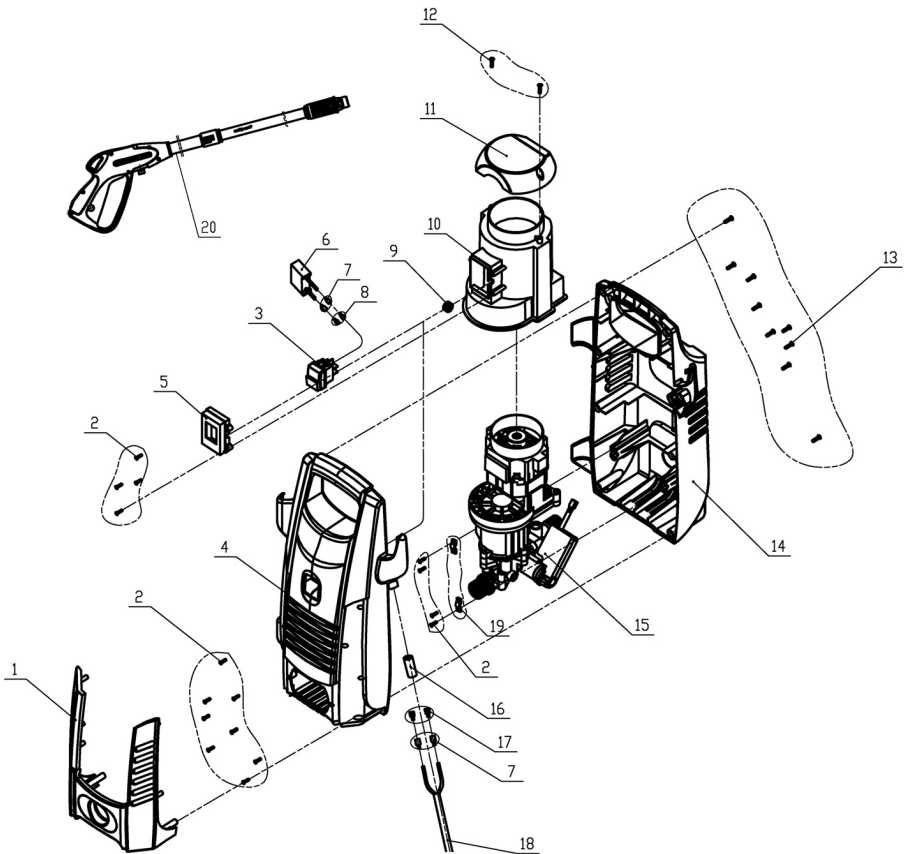

WARNING: TO ENSURE MACHINE SAFETY, USE ONLY ORIGINAL SPARE PARTS FROM CLARKE INTERNATIONAL.

PARTS LIST

NO	DESCRIPTION	PART NO
1	Upper Cover Panel	TMC1750H001
2	Selftapping Screw	TMC1750H002
3	Main Switch	TMC1750H003
4	Upper Cover	TMC1750H004
5	Switch Box	TMC1750H005
6	Capacitor	TMC1750H006
7	Insulating Guard	TMC1750H007
8	Plug-in Pieces	TMC1750H008
9	Bushing	TMC1750H009
10	Guard	TMC1750H010
11	Guard Cover	TMC1750H011
12	Selftapping Screw	TMC1750H012
13	Selftapping Screw	TMC1750H013
14	Base	TMC1750H014
15	Pump	TMC1750H015
16	Power Cord Guard	TMC1750H016
17	Plug-in Pieces	TMC1750H017
18	Power Cord With Plug	TMC1750H018
19	Power Cord Press Board	TMC1750H019
20	Gun & Lance Assembly	TMC1750H020
21	High Pressure Hose (Not Shown)	TMC1750H021

DECLARATION OF CONFORMITY



Clarke[®]
INTERNATIONAL

Hemnall Street, Epping, Essex CM16 4LG

DECLARATION OF CONFORMITY

This is an important document and should be retained.

Product Description: Power Washer
Model number(s): Jetstar1750
Serial / batch Number: N/A
Date of Issue: 01/11/2010
(Noise Conformity)
Notified Body: TÜV SÜD Industrie Service GmbH
Westendstraße 199
80686 MÜNCHEN
Germany

Technical Documentation Holder: A.R. Pond
Clarke International
2a Shrubland Road
London E10,7RB
UK

Conformity Assessment Procedure: to 2000/14/EC Annex V
Manufacturer: Clarke International
Noise Related Value: 5.0 l/min
Measured Sound Power Level: 90dB
Guaranteed Sound Power Level: 93dB



Clarke[®] INTERNATIONAL

Hemndall Street, Epping, Essex CM16 4LG

DECLARATION OF CONFORMITY

This is an important document and should be retained.

We hereby declare that this product(s) complies with the following directive(s):

- 2004/108/EC *Electromagnetic Compatibility Directive.*
- 2006/42/EC *Machinery Directive.*
- 2006/95/EC *Low Voltage Equipment Directive.*
- 2002/95/EC *Restriction of Hazardous substances.*
- 2000/14/EC *Noise Emissions Directive (amended by 2005/88/EC).*

The following standards have been applied to the product(s):

- BS EN 60335-1:2002+A1+A11+A12+A2+A13, BS EN 60335-2-79:2009, BS EN 62233:2008*
- BS EN 55014-1:2006+A1:2009, BS EN 55014-2:1997+A1, BS EN 61000-3-2:2006+A2:2009,*
- BS EN 61000-3-3:1995+A1+A2*

The technical documentation required to demonstrate that the product(s) meet(s) the requirement(s) of the aforementioned directive(s) has been compiled and is available for inspection by the relevant enforcement authorities.

The CE mark was first applied in: 2009

Signed:

J.A. Clarke
Director

A SELECTION FROM THE VAST RANGE OF

Clarke®

QUALITY PRODUCTS

AIR COMPRESSORS

From DIY to industrial, Plus air tools, spray guns and accessories.

GENERATORS

Prime duty or emergency standby for business, home and leisure.

POWER WASHERS

Hot and cold, electric and engine driven - we have what you need

WELDERS

Mig, Arc, Tig and Spot. From DIY to auto/industrial.

METALWORKING

Drills, grinders and saws for DIY and professional use.

WOODWORKING

Saws, sanders, lathes, mortisers and dust extraction.

HYDRAULICS

Cranes, body repair kits, transmission jacks for all types of workshop use.

WATER PUMPS

Submersible, electric and engine driven for DIY, agriculture and industry.

POWER TOOLS

Angle grinders, cordless drill sets, saws and sanders.

STARTERS/CHARGERS

All sizes for car and commercial use.

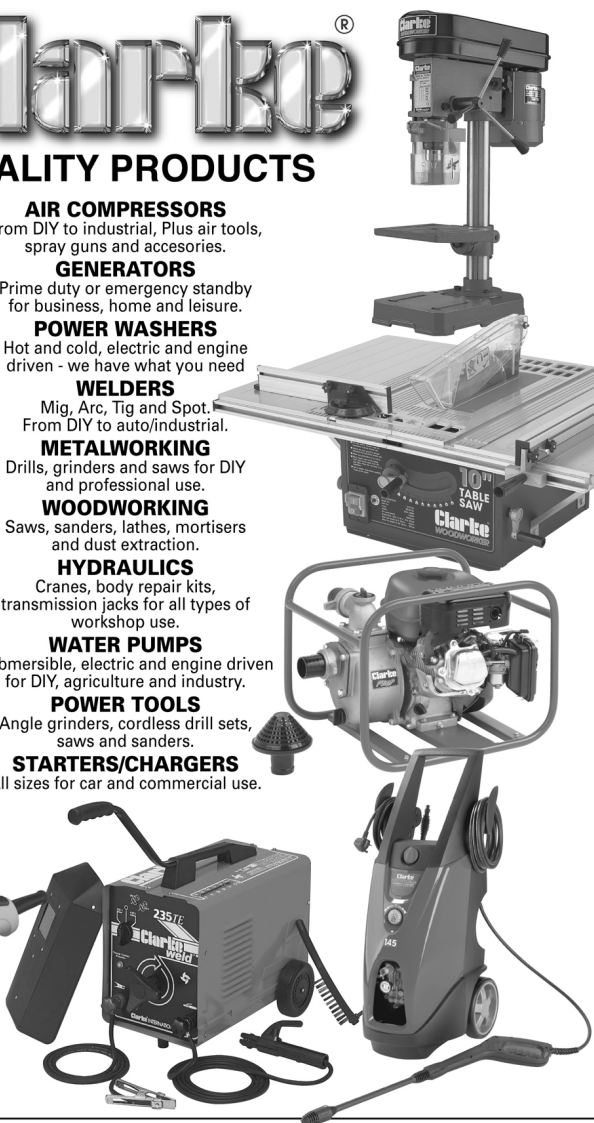

PARTS & SERVICE: 0208 988 7400

E-mail: Parts@clarkeinternational.com or Service@clarkeinternational.com

SALES: UK 01992 565333 or Export 00 44 (0)1992 565335

Clarke® INTERNATIONAL Hemnall Street, Epping, Essex CM16 4LG
www.clarkeinternational.com