

Serpentine Belt Tensioner Tool | Cooper S

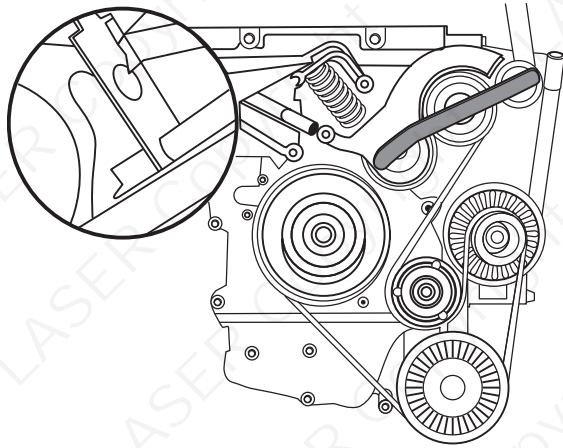

Use tool (A) to lever the tensioner back ensuring the pins fit properly into the holes in the tensioner arm and the $\frac{3}{4}$ round pivot bracket fits fully over the tensioner pivot mounting.

Insert the belt tensioner pin (C) (4mm) to hold the tension so that the belt can be removed without having to maintain any further pressure on the tool.

Safety Precautions - Please Read

- Do not run the engine with the serpentine belt removed.
- When checking the belt fit, it is best practice to remove the spark plugs to make turning the engine easier.
- Observe all tightening torques.
- Do not use cleaning fluids on belts, sprockets or rollers
- Do not lever or force the belt onto its sprockets
- Do not use locking pins to lock the engine when slackening or tightening the crankshaft pulley bolts

ALWAYS REFER TO THE VEHICLE MANUFACTURERS WORKSHOP MANUAL



www.lasertools.co.uk



Distributed by The Tool Connection Ltd
Kineton Road, Southam, Warwickshire CV47 0DR
T +44 (0) 1926 815000 F +44 (0) 1926 815888
info@toolconnection.co.uk www.toolconnection.co.uk

Guarantee

If this product fails through faulty materials or workmanship, contact our service department direct on: **+44 (0) 1926 818186**. Normal wear & tear are excluded as are consumable items & abuse.

www.lasertools.co.uk

4770

LASER[®]

Serpentine Belt Tool Kit BMW Mini



This tool set simplifies the removal and replacement of the Serpentine Belt when servicing | repairing the W10 | W11 1600cc engines as used in the Mini One | Cooper | Cooper S (pre. 2007 | Mk1), Mini Convertible (pre 2009 | Mk1).

www.lasertools.co.uk

Application

BMW Mini One | Cooper | Cooper S 1.6 Petrol engines (MK1)
W10B16AA | W10B16BA | W11B16AA engines



Layout ID	Component Code	OEM Ref	Description
A	C435	11 8 410	Serpentine Belt Tensioning Tool - Cooper S
B	C438	11 8 390	Serpentine Belt Tensioning Tool - Cooper Mini One
C	C436	11 8 470	Belt Tensioner Locking Pin 4mm
D	C437	11 8 280	Belt Tensioner Locking Pin 4.5mm

Instructions for Use

Always refer to the vehicle manufacturer's service manual or a suitable proprietary instruction book.

Warning – Incorrect fitting of the serpentine belt could result in engine damage. It is strongly recommended that the engine be rotated after fitting a new belt to ensure the belt is correctly fitted and aligned.

General Instructions

Gain Access to Serpentine Belt

- Remove the engine under tray
- Remove the right front wheel
- Remove the right front inner wheel arch to allow access to the lower serpentine belt pulleys
- Remove the fuel tank evaporative control valve (mounted on front right hand end of the engine)



Serpentine Belt Tensioner Tool | Mini One | Cooper (B)

- Use Tool (B) to lever the tensioner away from the belt ensuring the claw fits properly onto the end of the tensioner arm.
- With the tensioner levered fully back insert pin (D) (4.5mm) into the tensioner to hold the tensioner free of the belt and aid removal and fitting of the belt.

