

A SELECTION FROM THE VAST RANGE OF

Clarke®

QUALITY PRODUCTS

AIR COMPRESSORS

From DIY to industrial. Plus air tools, spray guns and accessories.

GENERATORS

Prime duty or emergency standby for business, home and leisure.

POWER WASHERS

Hot and cold, electric and engine driven - we have what you need.

WELDERS

Mig, Arc, Tig and Spot. From DIY to auto/industrial.

METALWORKING

Drills, grinders and saws for DIY and professional use.

WOODWORKING

Saws, sanders, lathes, mortisers and dust extraction.

HYDRAULICS

Cranes, body repair kits, transmission jacks for all types of workshop use.

WATER PUMPS

Submersible, electric and engine driven for DIY, agriculture and industry.

POWER TOOLS

Angle grinders, cordless drill sets, saws and sanders.

STARTER/CHARGERS

All sizes for car & commercial use.



Clarke®

WOODWORKER

WOODEN WORKBENCH

MODEL: CHB1500

Part No. 6500126



ASSEMBLY INSTRUCTIONS



Clarke INTERNATIONAL

For spare parts and servicing, please contact your nearest dealer, or Clarke International on

020 - 8988 - 7400

e-mail: Parts@clarkeinternational.com e-mail: Service@clarkeinternational.com

Hemnal Street, Epping, Essex CM16 4LG

ASSEMBLY



The Completed Workbench

ASSEMBLY

Fit the drawer and clamps as shown.

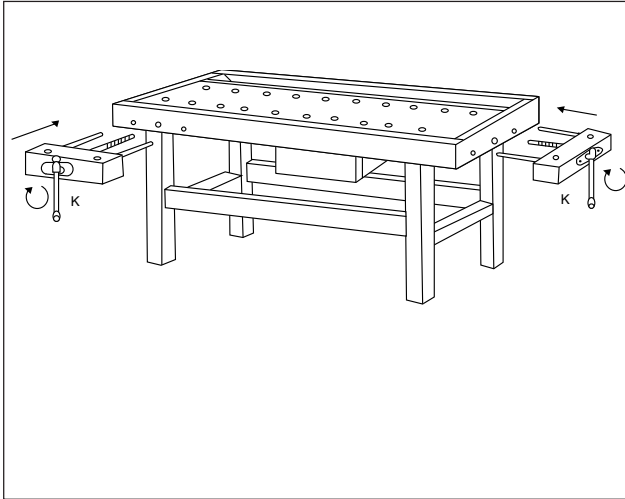

Fit the pins and dogs as required.



INTRODUCTION

Thank you for purchasing this CLARKE Wooden Workbench.

Please read these instructions carefully in order to ensure that the workbench is assembled correctly, thereby ensuring that it provides you with long and satisfactory service.

GUARANTEE







This CLARKE product is guaranteed against faulty manufacture for a period of 12 months from the date of purchase. Please keep your receipt as proof of purchase.

This guarantee is invalid if the product is found to have been abused or tampered with in any way, or not used for the purpose for which it was intended.

Faulty goods should be returned to their place of purchase, no product can be returned to us without prior permission.

This guarantee does not effect your statutory rights.

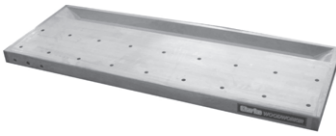
PACK CONTENTS

<p>A</p> <p>Side pieces</p>	 <p>x2</p>
<p>B</p> <p>Left leg frame</p>	 <p>x1</p>
<p>C</p> <p>Right leg frame</p>	 <p>x1</p>
<p>D</p> <p>Shelf base</p>	 <p>x1</p>
<p>E</p> <p>Drawer Holder</p>	 <p>x2</p>
<p>F</p> <p>Workbench</p>	 <p>x1</p>
<p>G</p> <p>Drawer Front</p>	 <p>x1</p>
<p>H</p> <p>Drawer Side</p>	 <p>x2</p>

DRAWER ASSEMBLY

1



1. Fit the rear of the drawer (J) to one of the drawer sides (H) and fix into position using the hinge and screws provided.

2



2. Fit the other side (H) as shown.

3



3. Rotate the drawer and slide the drawer base (I) into position.

4

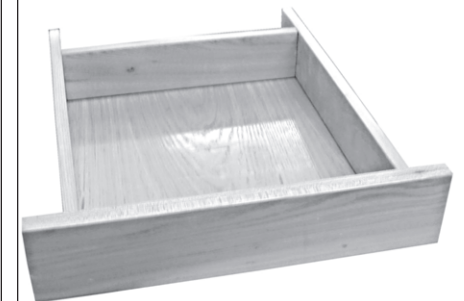

4. Fix the drawer front (G) as shown above.

The drawer is now complete.

ASSEMBLY

- Lay the workbench (F) on it's top.
- Place the Legs into position and secure in place using Bolts (O) and Washers (Q).

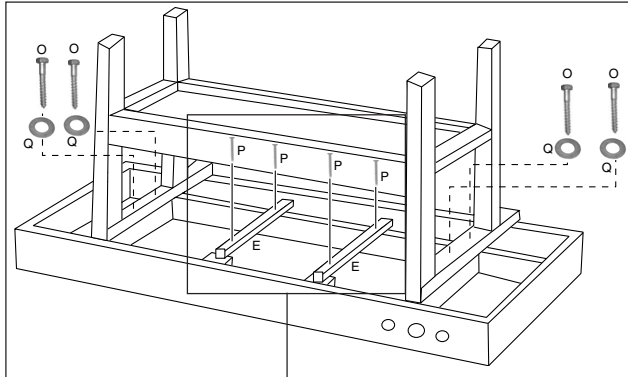

- Fix the drawer holders (E) into place using the four long wood screws (P) supplied.



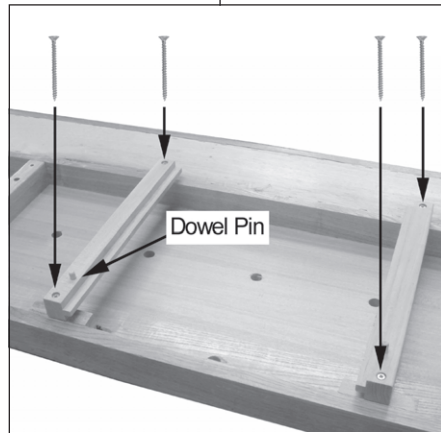





Make sure that the dowel pins on the drawer holders are positioned towards the front of the workbench.

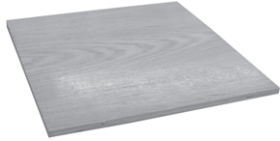

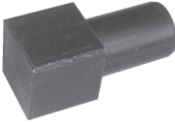
At this stage the frame should look like this.



PACK CONTENTS

I	Drawer base		x1
J	Drawer rear		x1
K	Clamp		x2
L	Workbench dog		x4
M	Workbench pin		x4
N	Shelf nut and bolt		x4
O	Wood Bolt		x4
P	 x4  x8	Washer 	x8

ASSEMBLY

1. Insert the nuts from part (N) into the side pieces (A).

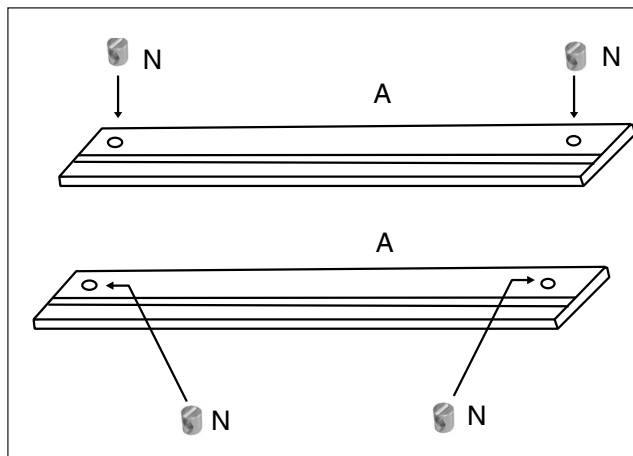

2. Use the Bolts (N) and Washers (Q) to secure both leg frames (B and C) to one of the side pieces.

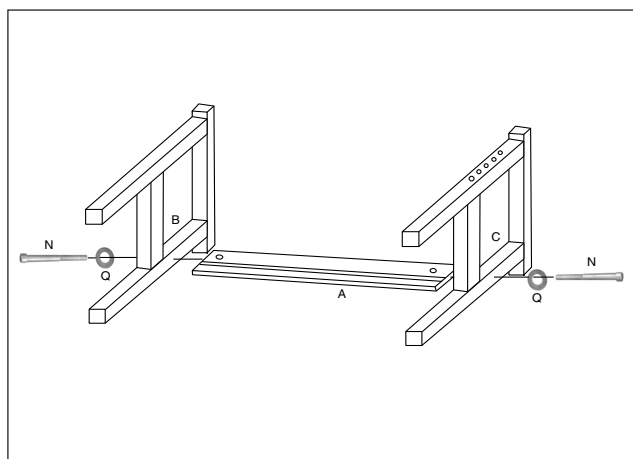

At this stage the frame should look like this.



ASSEMBLY

3. Slide the shelf base (D) into the grooves as shown.

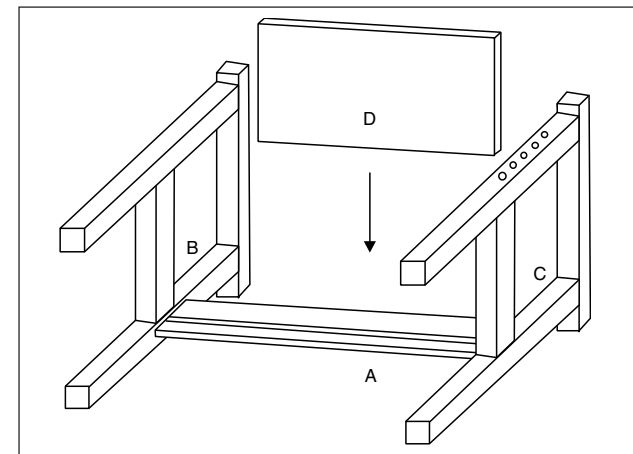

4. Secure the second side piece to the two leg frames using Bolts (N) and Washers (Q).

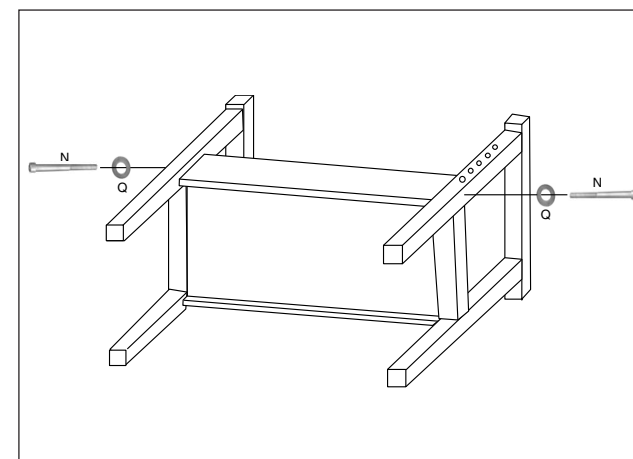

At this stage the frame should look like this.

