

# Charlton®



## LOG SPLITTER

MODEL NO: LOGBUSTER 5

PART NO: 3402030

## OPERATION & MAINTENANCE INSTRUCTIONS



LS0714

---

## INTRODUCTION

---

Thank you for purchasing this CLARKE Log Splitter.

Before attempting to use this product, please read this manual thoroughly and follow the instructions carefully. In doing so you will ensure the safety of yourself and that of others around you, and you can look forward to your purchase giving you long and satisfactory service.

---

## GUARANTEE

---

This product is guaranteed against faulty manufacture for a period of 12 months from the date of purchase. Please keep your receipt which will be required as proof of purchase.

This guarantee is invalid if the product is found to have been abused or tampered with in any way, or not used for the purpose for which it was intended.

Faulty goods should be returned to their place of purchase, no product can be returned to us without prior permission.

This guarantee does not effect your statutory rights.

---

## ENVIRONMENTAL RECYCLING POLICY

---



Through purchase of this product, the customer is taking on the obligation to deal with the WEEE in accordance with the WEEE regulations in relation to the treatment, recycling & recovery and environmentally sound disposal of the WEEE.

In effect, this means that this product must not be disposed of with general household waste. It must be disposed of according to the laws governing Waste Electrical and Electronic Equipment (WEEE) at a recognised disposal facility.

---

# GENERAL SAFETY RULES

---



**WARNING: READ ALL INSTRUCTIONS. FAILURE TO FOLLOW ALL INSTRUCTIONS LISTED BELOW MAY RESULT IN ELECTRIC SHOCK, FIRE AND/ OR SERIOUS INJURY. SAVE THESE INSTRUCTIONS.**

---

## WORK AREA

1. **Keep the work area clean and well lit.** Cluttered and dark areas invite accidents.
2. **Do not operate log splitters in explosive atmospheres, such as in the presence of flammable liquids, gases or dust.** Log splitters create sparks which may ignite the dust or fumes.
3. **Keep children and bystanders away while operating the log splitter.** Distractions can cause you to lose control.
4. **The surface must be perfectly level to prevent the machine from moving during operation.**

## ELECTRICAL SAFETY

1. **The log splitters plug must match the outlet. Never modify the plug in any way.** Unmodified plugs and matching outlets will reduce risk of electric shock.
2. **Avoid body contact with earthed or grounded surfaces such as pipes, radiators, ranges and refrigerators.** There is an increased risk of electric shock if your body is earthed or grounded.
3. **Do not expose log splitters to rain or wet conditions.** Water entering a log splitters will increase the risk of electric shock.
4. **Do not abuse the cord. Never use the cord for carrying, pulling or unplugging the log splitter. Keep cord away from heat, oil, sharp edges or moving parts.** Damaged or entangled cords increase the risk of electric shock.
5. **When operating the log splitter outdoors, use an extension cord suitable for outdoor use.** Use of a cord suitable for outdoor use reduces the risk of electric shock.
6. **Do not leave the log splitter unattended when plugged in to the mains supply.**

## PERSONAL SAFETY

1. **Stay alert, watch what you are doing and use common sense when operating a log splitter. Do not use the log splitter while you are tired or under the influence of drugs, alcohol or medication.** A moment of inattention while operating log splitters may result in serious personal injury.
2. **Use safety equipment. Always wear eye protection.** Safety equipment such as non-skid safety shoes, close fitting clothing and suitable work gloves should always be used.
3. **Avoid accidental starting. Ensure the switch is in the off position before plugging in.**
4. **Do not overreach. Keep proper footing and balance at all times.** This enables better control of the log splitters in unexpected situations.

5. **Dress properly. Do not wear loose clothing or jewellery. Keep your hair, clothing and gloves away from moving parts.** Loose clothes, jewellery or long hair can be caught in moving parts.

## USAGE AND CARE

1. **Do not force the log splitter.** It will do the job better and safer at the rate for which it was designed.
2. **Disconnect the plug from the power source before making any adjustments, changing accessories, or storing the log splitter.** Such preventive safety measures reduce the risk of starting the log splitter accidentally.
3. **Store the log splitter out of the reach of children and do not allow persons unfamiliar with log splitters or these instructions to operate the log splitter.** Log splitters are dangerous in the hands of untrained users.
4. **Maintain the log splitter. Check for misalignment or binding of moving parts, breakage of parts and any other condition that may affect the log splitters operation. If damaged, have the log splitter repaired before use.** Many accidents are caused by poorly maintained power tools.
5. **Keep cutting tools sharp and clean.** Properly maintained cutting tools with sharp cutting edges are less likely to bind and are easier to control.

## SERVICE

1. **Have your power tool serviced by a qualified repair person using only identical replacement parts.** This will ensure that the safety of the power tool is maintained.

---

## ADDITIONAL SAFETY RULES FOR LOG BUSTERS

---

Extra special care is required when using this powerful tool to safeguard yourself and that of others around you.

1. Never tamper with the log buster or attempt to operate the machine without covers fitted.
2. Never work with the machine on the ground. This is not only an uncomfortable working position but it can also be dangerous because the operator has to bend towards the machine, and thus risk being struck by chips or debris.
3. The log buster must be used on a raised surface, of sufficient height, so that when the log buster is mounted, the main bed of the machine is no higher or lower, than the extended arms of the operator, without the operator having to bend forward.
4. Do not allow split logs to accumulate, always clean up as you work, accumulated split logs and wood chips can create a hazardous work environment.
5. The operator must operate the machines controls with both hands without using other makeshift systems, i.e. wedging control levers down etc.
6. The machine must always be used by one operator only. Nobody must be allowed to use the log buster unless they have read the instruction manual thoroughly and have been instructed in its use. The machine must be used by adults only. Check that the logs to be split are free from nails or wire, which may fly up or damage the

machine. The ends of the logs must be cut square. Branches must be cut off flush with the trunk.

7. Never attempt to split two logs at once; one may be ejected with possibly serious damage.
8. Split wood in the direction of the grain. Do not attempt to split a piece of wood across the grain as this could seriously damage the machine.
9. If the log moves away from the blade, retract the ram and rotate the log through 90°
10. Do not attempt to load the log in the machine whilst the log pusher is in motion.
11. Keep your hands well away from any splits and cracks which open in the log.
12. Do not force the blade by pushing the log on the upper part, as this can cause the blade to break or damage the body of the machine. Always set the log on the guides.
13. Never leave the machine unattended while it is running. If you leave the machine, even for a short time, disconnect from the power supply.
14. Never use the machine whilst under the influence of alcohol, drugs, medicines, or when you are tired. A clear mind is essential for safety.
15. Never request the assistance of another person to help you remove a jammed log.
16. Always disconnect the power cable when not in use, when carrying out maintenance work or when moving the machine.
17. Never use the Log buster if it is not in perfect order or if it needs servicing.
18. Before starting work, check correct functioning of all the safety devices and check for soundness of welded joints, securing nuts & bolts.

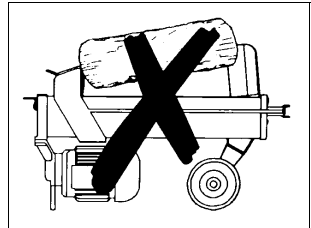

## SIZE OF THE LOGS BEING SPLIT

The image on the right shows the maximum log size that can be split.

- It is important not to attempt to split a log for longer than 5 seconds as the pump may be damaged by the oil overheating. This could occur when the wood being split is excessively fibrous, knotty or wet, green wood.

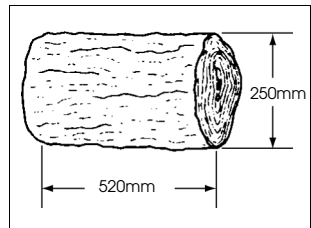

**NOTE:** The diameter of the log is indicative: i.e. A small log can be difficult to split if it has knots or a particularly tough fibre.

- It is therefore better to stop and rotate the log by 90°, as shown above, to see whether it can be split in a different plane.
- Not being able to split the log within this time, indicates that its hardness exceeds the capacity of the machine and it should therefore be discarded so as not to cause damage/injury.

# SAFETY SYMBOLS



**READ  
INSTRUCTIONS  
BEFORE USE**



**WEAR  
SAFETY  
GLASSES**



**WEAR  
PROTECTIVE  
GLOVES**



**WEAR  
PROTECTIVE  
BOOTS**



**DANGER OF CUTTING  
OR CRUSHING OF  
THE HAND**



**ALWAYS PAY ATTENTION  
TO THE MOVEMENT OF  
THE MACHINE**



**PROTECT YOUR HANDS**



**DISCONNECT POWER  
WHEN NOT IN USE**



**THIS MACHINE MUST ONLY BE  
OPERATED BY ONE PERSON**

**KEEP VISITORS  
& CHILDREN A  
SAFE DISTANCE  
AWAY FROM  
THE WORK  
AREA WHILST  
IN OPERATION**



**INSPECT THE LOG BUSTER BEFORE  
USE FOR ANY DAMAGE ETC**



**PROTECT THE ENVIROMENT**

---

## ELECTRICAL CONNECTIONS

---

Connect the mains lead to a standard, 230 Volt (50Hz) electrical supply through an approved 13 amp BS 1363 plug, or a suitably fused isolator switch.



**WARNING: THIS APPLIANCE MUST BE EARTHED**

---

**IMPORTANT: The wires in the mains lead are coloured in accordance with the following code:**

Green & Yellow	-	Earth
Blue	-	Neutral
Brown	-	Live

As the colours of the flexible lead of this appliance may not correspond with the coloured markings identifying terminals in your plug proceed as follows:

- Connect GREEN & YELLOW cord to terminal marked with a letter "E" or Earth symbol "⏏" or coloured GREEN or GREEN & YELLOW.
- Connect BROWN cord to terminal marked with a letter "L" or coloured RED.
- Connect BLUE cord to terminal marked with a letter "N" or coloured BLACK.

If this appliance is fitted with a plug which is moulded onto the electric cable (i.e. non-rewireable) please note:

1. The plug must be thrown away if it is cut from the electric cable. There is a danger of electric shock if it is subsequently inserted into a socket outlet.
2. Never use the plug without the fuse cover fitted.
3. When replacing a detachable fuse carrier, ensure the correct replacement is used (as indicated by marking or colour code).
4. Replacement fuse covers can be obtained from your local dealer or most electrical stockists.

### FUSE RATING

The fuse in the plug must be replaced with one of the same rating (13 amps) and this replacement must be ASTA approved to BS1362.

We strongly recommend that this machine is connected to the mains supply via a Residual Current Device (RCD)

If in any doubt, consult a qualified electrician. DO NOT attempt any repairs yourself.

# IDENTIFICATION OF PARTS

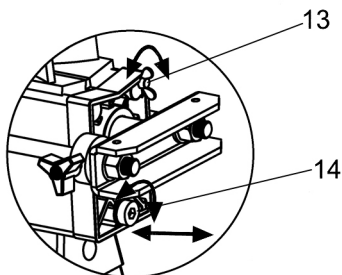
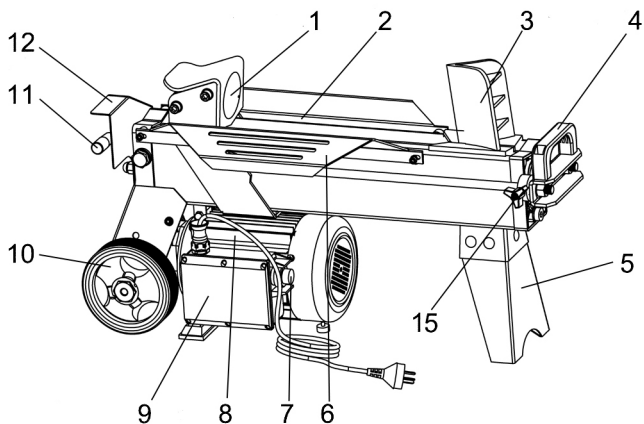

No	Description	Part number	No	Description	Part number
1	Log pusher plate	LGLOB501	9	Switch box	LGLOB509
2	Work table	LGLOB502	10	Wheels	LGLOB510
3	Wedge	N/A	11	Control lever	LGLOB511
4	Lifting handle	LGLOB504	12	Guard	LGLOB512
5	Support leg	LGLOB505	13	Bleed screw	LGLOB513
6	Log retaining plates	LGLOB506	14	Oil Drain bolt with dipstick	LGLOB514
7	Push button switch	LGLOB507	15	Return Stop	LGLOB515
8	Motor	LGLOB508			



---

## BEFORE USE

---

### BLEEDING THE HYDRAULIC SYSTEM

Before operating the log buster, the Bleed Screw should be loosened by 2-3 turns until air can go in and out of the oil tank smoothly.

- Air flow through the Bleed Screw hole should be detectable when the log buster is in operation.

Before moving the log buster, make sure the Bleed Screw is tightened to avoid oil leaking from this point.

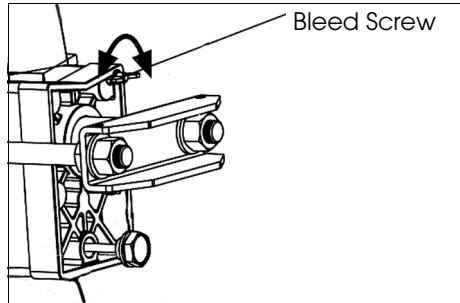

**WARNING: FAILURE TO DO THIS WILL CAUSE PERMANENT DAMAGE TO THE LOG BUSTER.**

---

### POSITIONING THE LOGS

- Always place the logs on the log retaining plates.
- Make sure the logs do not twist, rock or slip while being split.
- Do not force the log buster by splitting the log on the upper part of the wedge. This will break the wedge or damage the machine.
- Break log in the direction of its grain.
- Do not place the log across the log buster for splitting. It may be dangerous and may seriously damage the machine.
- Do not attempt to split 2 logs at the same time. One of them may fly up and hit you.

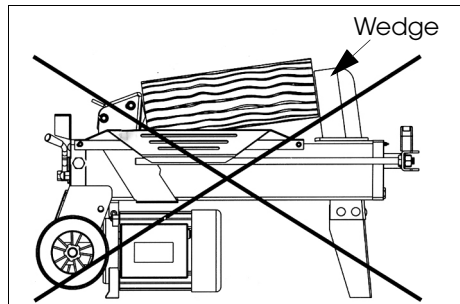

---

# OPERATION

---

## OPERATING THE LOG BUSTER

This log buster is designed to be operated by one person only and requires two handed operation by the user -

The left hand controls the hydraulic control lever and the right hand controls the push button switch.

1. Push and hold the push button switch
2. Then press and hold down the control lever to start the log buster.
  - The log buster will freeze if either control is released.
  - When both controls are released, the log pusher returns to the starting position.

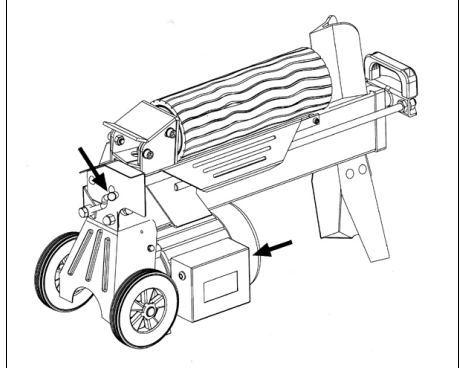

**NOTE:** Once you start splitting the log, never reach into the splitting zone.



**WARNING: NEVER FORCE THE LOG BUSTER FOR MORE THAN 5 SECONDS TO SPLIT EXCESSIVELY HARD WOOD. AFTER THIS TIME, THE OIL UNDER PRESSURE WILL OVERHEAT AND THE MACHINE COULD BE DAMAGED.**

For extremely hard logs, rotate the log by 90° to see whether it can be split in a different direction. In any case, if you are still not able to split the log, this means that the wood exceeds the capacity of the machine and should be discarded to protect the log buster.

## ADJUSTING THE RETURN STOPPING POINT

If you are splitting a pile of shorter logs you may want to prevent the pusher plate returning all the way back to the start, this will speed up future operations.

To adjust how far the pusher plate comes back:

1. Extend the ram fully, as shown in "Operating the Log Buster" .

**NOTE:** Do not put any logs on the log splitter at this stage.

2. When the ram is at full extension, release the push button switch.

- Keep the Control lever pressed down to prevent the ram from returning.

3. Loosen the handwheel on the return stop and slide the stop to the desired position

- Move the stop towards the splitter to shorten the stroke.

4. Tighten the handwheel on the return stop to lock it into position.

5. Make sure your hands are clear of the ram, and release the control lever.

- The ram should return as far as the stop will allow.

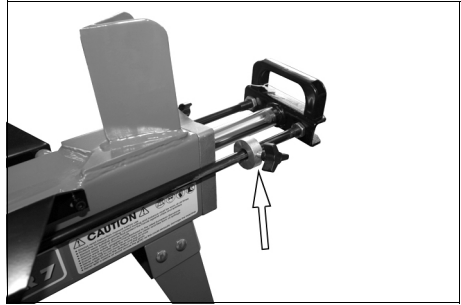

## **FREING A JAMMED LOG**

1. Release both controls.

- The log pusher moves back and completely stops at its starting position.

2. Insert a wedge wood under the jammed log.

3. Start the log buster to push the wedge wood to go completely under the jammed one.

4. Repeat above procedure with sharper sloped wedges of woods until the log is completely free.

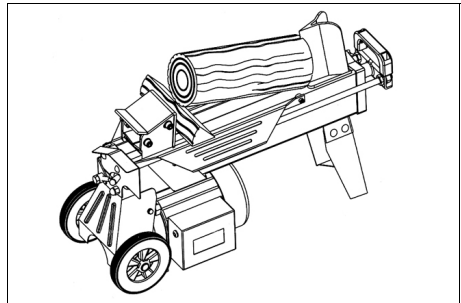

Do not try to hit the jammed log off of the log buster, this may damage the machine or may cause the log to fly up and cause an accident.

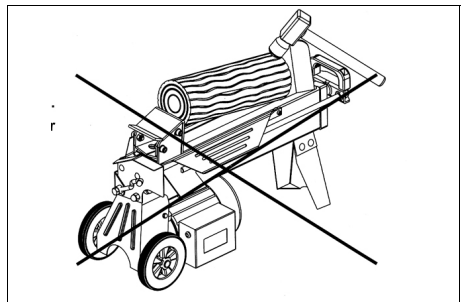

# MAINTENANCE



**WARNING: MAKE SURE THAT THE LOG SPLITTER IS SWITCHED OFF AND DISCONNECTED FROM THE MAINS SUPPLY BEFORE STARTING ANY CLEANING OR MAINTENANCE PROCEDURES.**

## REPLACING THE HYDRAULIC OIL

Replace the Hydraulic oil in the log buster after every 150 hours of use. Take following steps to replace it.

1. Place a container, large enough to hold 4 liters of oil under the oil filler plug, Loosen the bleed screw three or four turns.
2. Loosen and remove the oil filler plug/ dipstick, slowly tilt the machine to empty the oil.
3. To refill with new oil, tilt machine backwards, using a clean funnel, pour in 3.5 Liters of Clarke hydraulic oil,

**IMPORTANT: Only use CLARKE HYDRAULIC OIL, available from your nearest dealer.**

**Part No: 1Ltr - 3050830**

**5Ltr - 3050835**

4. Wipe the dipstick, using a clean soft cloth and check the oil level as before
  - Add more oil if required.
5. Clean the filler neck and plug/dipstick washer/seal thoroughly and refit, tighten sufficiently to prevent oil leaking, DO NOT overtighten.
6. Carefully return the machine to normal working position.
7. Finally, tighten the bleed screw.

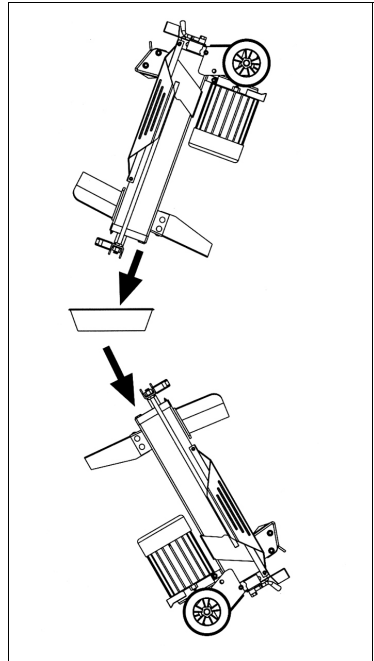

## SHARPENING WEDGE

After using the log busters for some time, sharpen the wedge of the log buster using a fine-toothed file and smooth any burrs or crushed area along the cutting edge.

## TRANSPORT AND STORAGE

### MOVING THE LOG BUSTER



CAUTION: BEFORE MOVING THE LOG BUSTER, MAKE SURE THE BLEED SCREW IS TIGHTENED TO AVOID OIL LEAKING.

- Lift the front of the log buster by the handle and move the log buster to the working area.

### STORAGE

When you have finish working with your log buster

1. Disconnect the log buster from the mains supply.
2. Tighten the bleed screw.
3. Clean the unit down using a dry cloth.

## TROUBLESHOOTING

PROBLEM	CAUSE	REMEDY
Fails to split logs	Log is improperly positioned.	Refer to "log buster Operation" section on page 9
	Wedge cutting edge is blunt.	Refer to "Sharpening Wedge" section See page 12
	Oil leaks	Contact the dealer
	Unauthorized adjustment was made on Max. Pressure Limiting Screw.	Contact the dealer.
The log pusher moves jerkily	Excessive air in the hydraulic system.	Check oil level for possible oil refilling. Contact the dealer.
Oil leaks around cylinder ram or from other points.	Air sealed in hydraulic system while operating.	Loosen Bleed Screw by 3- 4 turns before operating the log buster.
	Bleed Screw is not tightened before moving the log buster.	Tighten the Bleed Screw up before moving the log buster.
	Oil Drain Bolt is not tight.	Tighten the Oil Drain Bolt.
	Hydraulic Control Valve Assembly and / or seal(s) worn	Contact the dealer.

---

## SPECIFICATIONS

---

	<b>Logbuster 5</b>
Electrical Supply	230V @ 50Hz
Input Wattage	2000W
Part Number	3402030
IP Rating	IP54
Weight	44.5 Kg
Dimensions (L x W x H)	921 x 270 x 450 mm
A-weighted Sound Pressure Level dB (A)	<= 71 dB (A)
Log Capacity	
Maximum Length	520 mm
Minimum Length	300 mm
Maximum Diameter	250 mm
Minimum Diameter	50 mm

---

## PARTS AND SERVICING

---

For Parts & Servicing, please contact your nearest dealer, or  
CLARKE International, on one of the following numbers

**PARTS & SERVICE TEL: 020 8988 7400**  
**PARTS & SERVICE FAX: 020 8558 3622**  
**or e-mail as follows:**

PARTS: [Parts@clarkeinternational.com](mailto:Parts@clarkeinternational.com)  
SERVICE: [Service@clarkeinternational.com](mailto:Service@clarkeinternational.com)

# DECLARATION OF CONFORMITY



**Clarke**<sup>®</sup>  
**INTERNATIONAL**

Hemnoll Street, Epping, Essex CM16 4LG

## DECLARATION OF CONFORMITY

This is an important document and should be retained.

**We hereby declare that this product(s) complies with the following directive(s):**

*2004/108/EC Electromagnetic Compatibility Directive.*

*2006/42/EC Machinery Directive.*

*2006/95/EC Low Voltage Equipment Directive.*

*2002/95/EC Restriction of Hazardous substances.*

**The following standards have been applied to the product(s):**

*EN 60204-1:2006-1+A1:2009, EN 609-1:1999+A1:03+A2:2009,*

*EN 55014-1:2006+A1:2009+A2:2011, EN 55014-2:1997+A1:2001+A2:2008,*

*EN 61000-3-11:2000, EN 61000-3-2:2006+A1:2009+A2:2009.*

The technical documentation required to demonstrate that the product(s) meet(s) the requirement(s) of the aforementioned directive(s) has been compiled and is available for inspection by the relevant enforcement authorities.

The CE mark was first applied in: 2003

**Product Description:** 4, 5,5,4 Ton Log Splitters

**Model number(s):** Log buster's 5, 6, 7

**Serial / batch Number:** N/A

**Date of issue:** 01/11/2012

**Signed:**

  
.....  
**J.A. Clarke**  
**Director**

# A SELECTION FROM THE VAST RANGE OF

# Clarke®

## QUALITY PRODUCTS

### AIR COMPRESSORS

From DIY to industrial, Plus air tools, spray guns and accessories.

### GENERATORS

Prime duty or emergency standby for business, home and leisure.

### POWER WASHERS

Hot and cold, electric and engine driven - we have what you need

### WELDERS

Mig, Arc, Tig and Spot. From DIY to auto/industrial.

### METALWORKING

Drills, grinders and saws for DIY and professional use.

### WOODWORKING

Saws, sanders, lathes, mortisers and dust extraction.

### HYDRAULICS

Cranes, body repair kits, transmission jacks for all types of workshop use.

### WATER PUMPS

Submersible, electric and engine driven for DIY, agriculture and industry.

### POWER TOOLS

Angle grinders, cordless drill sets, saws and sanders.

### STARTERS/CHARGERS

All sizes for car and commercial use.



**PARTS & SERVICE: 0208 988 7400**

**E-mail: [Parts@clarkeinternational.com](mailto:Parts@clarkeinternational.com) or [Service@clarkeinternational.com](mailto:Service@clarkeinternational.com)**

**SALES: UK 01992 565333 or Export 00 44 (0)1992 565335**

**Clarke** INTERNATIONAL Hemnall Street, Epping, Essex CM16 4LG  
[www.clarkeinternational.com](http://www.clarkeinternational.com)