

# Clarke®

## STRONG-ARM

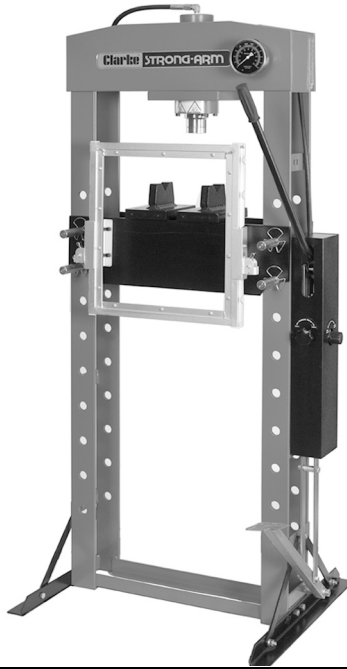

### 30 TONNE HYDRAULIC PRESS

#### MODEL NO: CSA30FP

PART NO: 7615200

## OPERATION & MAINTENANCE INSTRUCTIONS



**WARNING:** Read these instructions before using the machine

GC0516

---

# INTRODUCTION

---

Thank you for purchasing this CLARKE 30 Tonne Hydraulic Press.

Before attempting to operate the machine, it is essential that you read this manual thoroughly and carefully follow all instructions given. In doing so you will ensure the safety of yourself and that of others around you, and you can also look forward to the press giving you long and satisfactory service.

---

# GUARANTEE

---

This CLARKE product is guaranteed against faulty manufacture for a period of 12 months from the date of purchase. Please keep your receipt as proof of purchase.

This guarantee is invalid if the product is found to have been abused or tampered with in any way, or not used for the purpose for which it was intended.





Faulty goods should be returned to their place of purchase, no product can be returned to us without prior permission.

This guarantee does not effect your statutory rights.

---

# SAFETY SYMBOLS

---

	Hazard;-shattered workpiece		Hazard:- crushed hands
	Wear Safety Shoes		Wear safety glasses
	Read instruction manual before use		

The above safety symbols appear on the product.

---

## **SAFETY PRECAUTIONS**

---

- Due to the weight of the press, lifting equipment and the help of an assistant will be required during installation. Secure the press to a firm level floor using suitable anchor bolts (not supplied).
- Before starting work, check for signs of cracked welds, loose or missing bolts, damaged screen, or any other structural damage. Do not operate if any of these conditions exist. Have repairs made only by authorised service centre.
- Before work, always ensure that hydraulic hoses and couplings are completely sound.
- Never tamper with the press components or modify them. The safety valve is calibrated and sealed at the factory; do not attempt to change the setting.
- Use only the recommended hydraulic oil.
- The components of this press are designed to withstand the rated load. Do not substitute any other components or exceed the rated load of the press.
- Before applying pressure, ensure the workpiece is firmly secure and stable.
- Always clean up spills of hydraulic oil immediately as this can be dangerous in a workshop environment.
- Do not allow any person who is unfamiliar with hydraulic presses, to use the press unless they are under direct supervision.
- Keep children and unauthorised personnel away from the work area.
- Always position the safety screen directly front of the workpiece.
- Always apply the load under the centre of the ram. Offset loads can damage the ram and may cause the work piece to be ejected.
- Always ensure the work piece is properly supported by the press bed.
- When using accessories such as pressing plates, be certain they are centered below the ram and are in full contact with the bed.
- Parts being pressed may shatter or be ejected from the press. Always use adequate guards, and wear eye protection and protective clothing when using this press.
- Keep hands and fingers away from parts that may pinch or shift.
- Never use extension tubes to increase the length of the pump handle. Excessive effort can cause damage and/or accidents.
- Wear approved impact safety goggles and heavy duty work gloves.
- Failure to heed these warnings may result in damage to the equipment, or serious personal injury.

# UNPACKING & INVENTORY

Ensure the press and its components suffered no damage during transit and that all components are present. Should any loss or damage become apparent, please contact your CLARKE dealer immediately. The following items should be present in their packages.

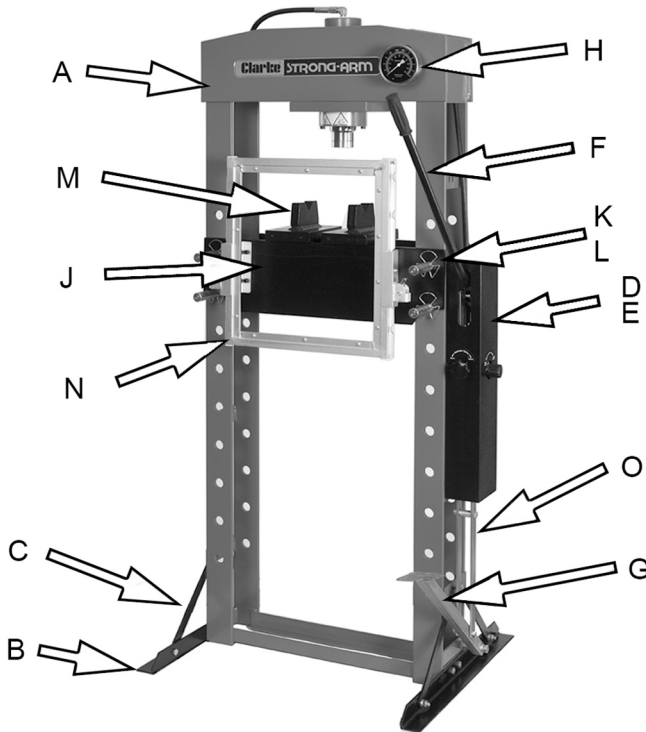

A	1 x Frame with ram / carrier assembly & hose
B	2 x Base Supports
C	4 x Stay Bars
D	1 x Pump with hose attached
E	1 x Pump Protective Cover
F	1 x Pump Handle
G	1 x Foot Pedal
H	1 x Pressure Gauge

J	1 x Pressing Bed
K	4 x Bed Support Pins
L	8 x Retaining Spring Clips
M	2 x Bed Blocks (V-blocks)
N	1 x Protective Screen Assembly
O	2 x Foot Pedal Connecting Bars
	1 x Fixing Kit (bolts,nuts, washers)

# ASSEMBLY



**WARNING: DUE TO THE WEIGHT OF THE PRESS, LIFTING EQUIPMENT OR THE HELP OF AN ASSISTANT WILL BE REQUIRED DURING INSTALLATION.**

## TOOLS REQUIRED

- Wrench/socket set
- PTFE tape
- Hex key set

## ASSEMBLY PROCEDURE

**IMPORTANT:** *The press must be firmly secured to a firm and level floor using expansion bolts (not supplied). Holes are provided in the feet for this purpose.*

**IMPORTANT:** *Do not locate your press where it will be open to the elements, as severe weather conditions will damage the hydraulic parts.*

1. With the help of an assistant, attach the base supports to the frame using the nuts, bolts and washers.
2. Add the stay bars to each side and bolt into place.
3. Using suitable lifting equipment if required, lift the frame assembly upright and manoeuvre it to its intended location in the workshop.
4. Bolt the hydraulic pump into position on the side of the frame using the fixing bolts and washers.

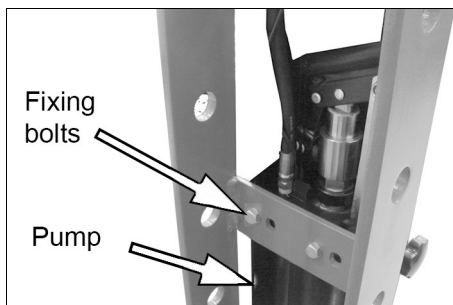
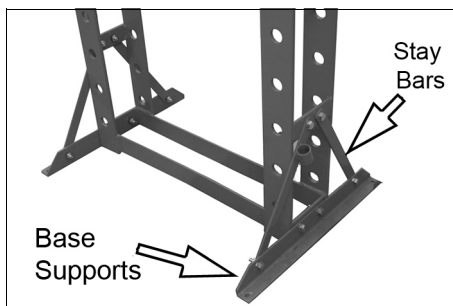

5. Fit the pressure gauge through the frame and secure loosely with the large nut supplied. Remove any protective bung from the gauge before fitting.

We recommend sealing all threads with PTFE tape where hydraulic oil is to be contained. Take care not to let any oil escape while connecting the hoses.

6. Screw the block connector and the connecting piece to the pressure gauge inlet.
7. Bolt the block connector to the back of the frame and connect the pump hose to the block connector as shown.
8. Connect the ram hose to the block connector.
9. Bolt the foot pedal to the frame using the long bolt, spacer tube, nut and washers.
10. Bolt the connecting bars to the operating arm of the pump. Bolt them together as a pair fitting the short spacers in both positions as shown.
11. Bolt the other end to the foot pedal.

12. Insert the bed support pins into the holes in the frame side supports at a height of your choosing. Secure them in position using the spring clips.

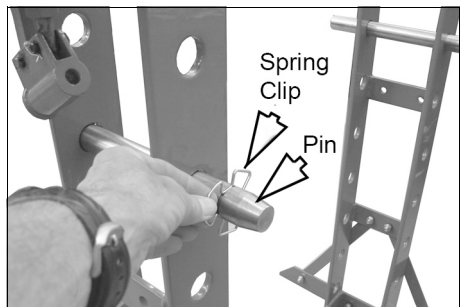
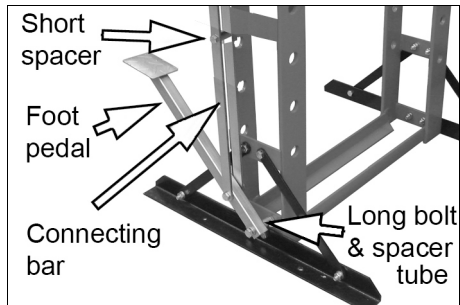
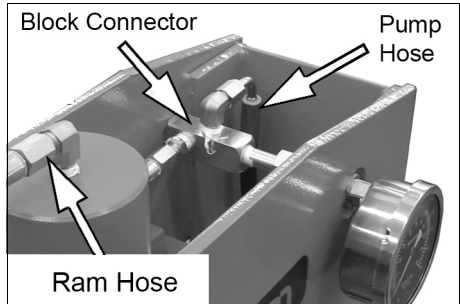
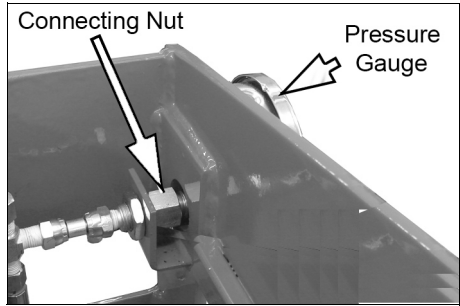

13. Fit the protective cover over the pump assembly using the screws supplied.

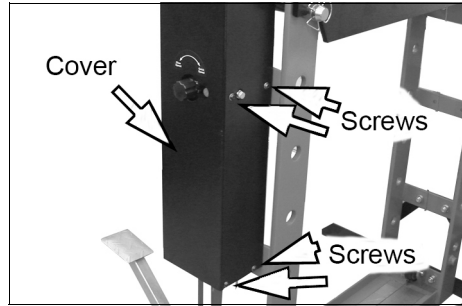

14. Lift the pressing bed into position on the pins.

**IMPORTANT: Due to the weight of the bed, we recommend that you get assistance from another person.**

15. Bolt the protective screen brackets to the pressing bedplate.

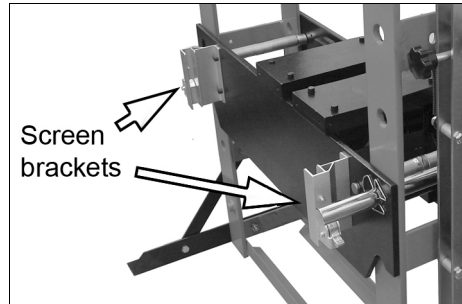

16. Fit the protective screen to the pressing bed and ensure it can be set in one of the available positions using the latches on each side.

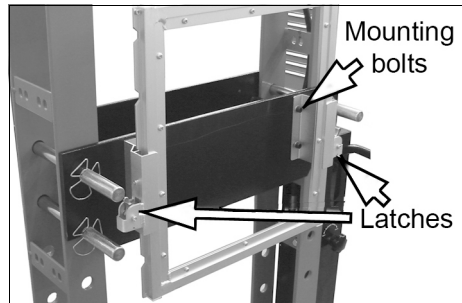

# PREPARATION FOR USE

## PURGING THE HYDRAULIC SYSTEM

1. Insert the pump handle into the actuating lever.
2. Open the release valve by turning anti-clockwise.
3. Pump several full strokes to eliminate any air bubbles from the system. Use either the handle or the foot pedal.
4. Close the release valve by turning clockwise.
5. Top up the hydraulic oil to the lower level of the filler plug with CLARKE hydraulic oil, Part No. 3050830.

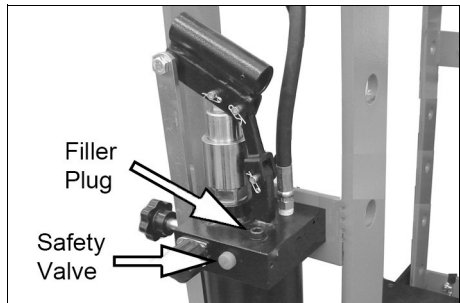
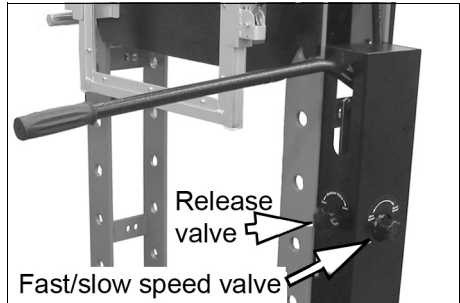

## POSITIONING THE PRESSING BED

***IMPORTANT: Due to the weight of the press bed, we recommend that you get assistance from another person when adjusting the bed height.***

1. Position the pressing bed so that it will be as close as possible to the ram when the workpiece is mounted on it.
2. Raise one side of the bed and insert a bed supporting pin into the next locating hole.
3. Repeat at the other end to level the bed.
4. Repeat until the bed is at the required height, with the bed supporting pins are secured using the spring clips.



CAUTION: THE BED HEIGHT SHOULD ONLY BE RAISED OR LOWERED ONE HOLE AT A TIME, WORKING ALTERNATELY FROM ONE SIDE AND THEN THE OTHER, FAILURE TO WORK IN THIS WAY MAY CAUSE THE BED TO FALL AND CAUSE INJURY TO THE OPERATOR.



## POSITIONING THE RAM

1. Slide the carriage along the cross-beam.
2. Lock it in position with the four sprung locking bolts.

**IMPORTANT:** Always position the ram directly above the workpiece.

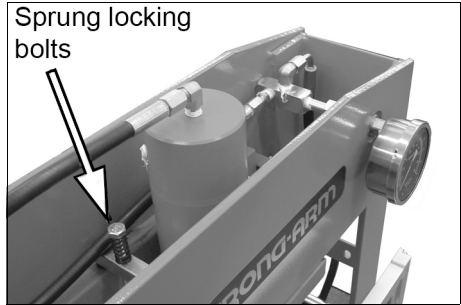

## POSITIONING THE PRESSING BLOCKS

The bed blocks can be placed on the bed with either the flat face or the V-supports facing upwards.

They are prevented from slipping out of position by the retaining pins which drop down within the confines of the bed side members.

Check all parts are secure and correctly aligned before using the press.

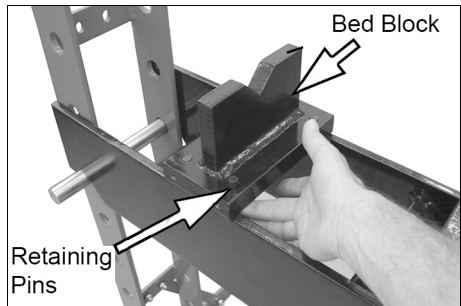

# OPERATION

1. Place the workpiece on the bed. It must be completely stable and supported by packing or shims where required. Pressing plates (bed blocks) are supplied, which locate on the bed. Place the workpiece on these to give it stability.



CAUTION: DO NOT POINT LOAD SUCH ACCESSORIES AS THEY ARE NOT DESIGNED TO TAKE THE FULL FORCE OF THE RAM IN ONE SPOT. ENSURE THEY ARE ADEQUATELY SUPPORTED.

**NOTE:** Any packing pieces or shims used *MUST* be capable of withstanding the pressure that will be brought to bear, and *MUST* be of sufficient size with sufficient surface area, so as to avoid the possibility of slipping or springing out. Mating surfaces *MUST* be horizontal so that the force being exerted will *NOT* be at an angle.

2. Close the release valve by turning clockwise until tightly closed.
3. Select either SLOW SPEED or FAST SPEED using the knob on the side of the pump cover.

**NOTE:** Fast speed allows faster movement but greater effort will be required.

4. Pump the handle or foot pedal to bring the ram very lightly into contact with the workpiece.
5. Manoeuvre the workpiece or loosen the bolts and slide the ram to one side so that the desired point of contact is directly beneath the centre of the ram.
6. When satisfied that the workpiece is correctly aligned and is completely stable in that position, raise the protective screen into position before starting any pressing.
7. Slowly pump the handle or foot pedal so that the ram begins to exert pressure on the workpiece.

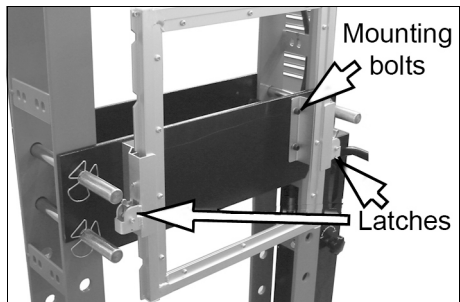
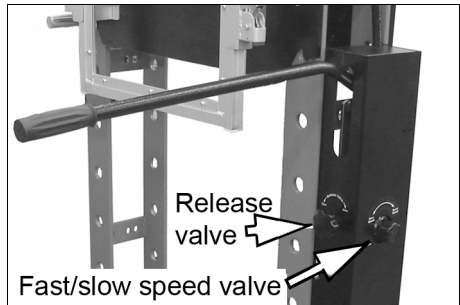

8. Continue to pump the handle and constantly monitor the process, ensuring the ram and work remain completely in line and there is no risk of slipping.
9. Observe the reading on the pressure gauge and take care not to exceed the rated working pressure of the press.

**NOTE:** The scale from 30 metric tonnes upward is highlighted in red, indicating pressure being applied above the rated maximum working pressure.

10. When the pressing process is complete, turn the release valve anticlockwise in small increments to release ram pressure and allow removal of the workpiece and lower the protective screen.

---

## TROUBLESHOOTING

---

Problem	Probable Cause	Remedy
Pump will not work.	Dirt on valve seat/worn seals.	Bleed pump unit or have unit overhauled with new seals by your Clarke dealer.
Pump will not produce pressure. Pump feels hesitant under load. Pump will not lower completely.	Air-lock.	Open the release valve and remove the oil filler plug. Pump the handle a couple of full strokes and close the release valve. Replace the filler plug.
Pump will not deliver pressure.	Reservoir could be over-filled or have low oil level.	Check oil level by removing the filler plug and topping up to the correct level.
Pump feels hesitant under load.	Pump cup seal could be worn out.	Have the cup seal replaced by your Clarke dealer.
Pump will not lower completely.	Air-lock.	Release air by removing the filler plug.

---

# MAINTENANCE

---

## ROUTINELY

A visual inspection must be made before each use of the press, checking for leaking hydraulic fluid and damaged, loose, or missing parts.

Owners and/or users should be aware that repair of this equipment requires specialised knowledge and facilities. It is recommended that a thorough annual inspection of the press be made and that any defective parts be replaced with genuine Clarke parts.

If the press appears to be damaged in any way, is found to be badly worn, or operates abnormally **SHOULD BE REMOVED FROM SERVICE** until the necessary repairs are made.

If the press is not to be used for any length of time, store it with the ram piston withdrawn to protect the surface of the moving parts.

## PERIODICALLY

Check the press to make sure all bolts are tight and inspect for cracked welds, bent, loose or missing parts.

Clean any foreign material from the ram carrier sliding plastic blocks. Keep the protective screen clean at all times.

Check the hydraulic connections for leaks. Replace or properly repair any damaged or leaking hydraulic components before using. In the event of leaking seals, oil can be topped up via the filler plug (P34-page 17) on the end of the pump. Oil should be level with the bottom of the hole. If necessary top up with CLARKE hydraulic oil, Part No. 3050830. **This task is carried out with the ram fully retracted.**

If any rust is apparent it must be removed completely and the paint restored.

## DISPOSAL OF UNWANTED MATERIALS

One of the most damaging sources of environmental pollution is oil products. Never throw away used oil with domestic refuse or flush it down a sink or drain. Collect any oil in a leak proof container and take it to your local waste disposal site.

Should hydraulic components become completely unserviceable and require disposal, draw off the oil into an approved container and dispose of the product and the oil according to local regulations.

---

## TECHNICAL SPECIFICATIONS

---

Capacity	30 Tonne
Operating Pressure	20,000 Mpa
Ram Travel	152 mm
Ram Shaft Diameter	58 mm
Net Weight	167 kg
Dimensions D x W x H	700 x 800 (exc pump) x 1850 mm
Throat Width	530 mm
Bed Adjustment Distance	110 mm
No of bed positions	9
Throat Depth (Ram to pressing plate)	Platform at highest;- 120 mm Platform at lowest;- 557 mm
Ram travel per stroke	2.7 mm
No of strokes to full extension	64
Pressure Gauge type	Accuracy class 2.5
Length of Handle	600 mm

# GENERAL ASSEMBLY PARTS DIAGRAM

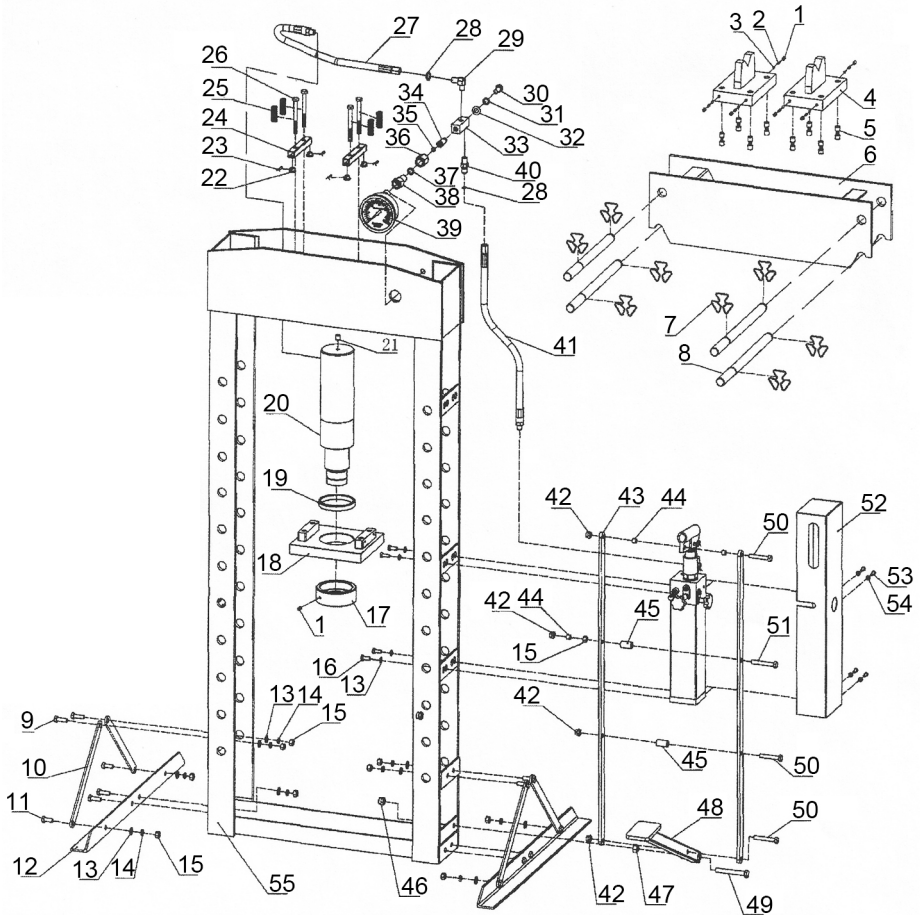

## FRAME ASSEMBLY PARTS LIST

NO	DESCRIPTION
1	Screw
2	Spring
3	Ball
4	Heel Block
5	Screw
6	Bed Frame
7	Circlip
8	Pin
9	Screw
10	Support
11	Screw
12	Frame Foot
13	Washer
14	Lock Washer
15	Nut
16	Screw
17	Ram Securing Collar
18	Ram Mounting Plate
19	Seating Ring
20	Ram Assembly
21	Screw
22	Slide Block
23	R-Clip
24	Axle
25	Spring
26	Adjusting Bolt
27	Hydraulic Hose
28	O-Ring

NO	DESCRIPTION
29	Elbow Fitting
30	Screw
31	Lock Washer
32	Washer
33	Lock Washer
34	Union Connector
35	Nylon Ring
36	Union Seat
37	O-Ring
38	Gauge Fitting
39	Pressure Gauge
40	Connector
41	Hydraulic Hose
42	Nut
43	Support
44	Bush
45	Spacer Tube
46	Nut
47	Nut
48	Foot Pedal
49	Bolt
50	Bolt
51	Bolt
52	Pump Protective Cover
53	Screw
54	Washer
55	Frame Assembly
56	Connecting Bar

**NOTE:** When requesting spare parts, please quote the prefix JHCSA30FP followed by the number on the diagrams/parts lists here.

# RAM PARTS DIAGRAM

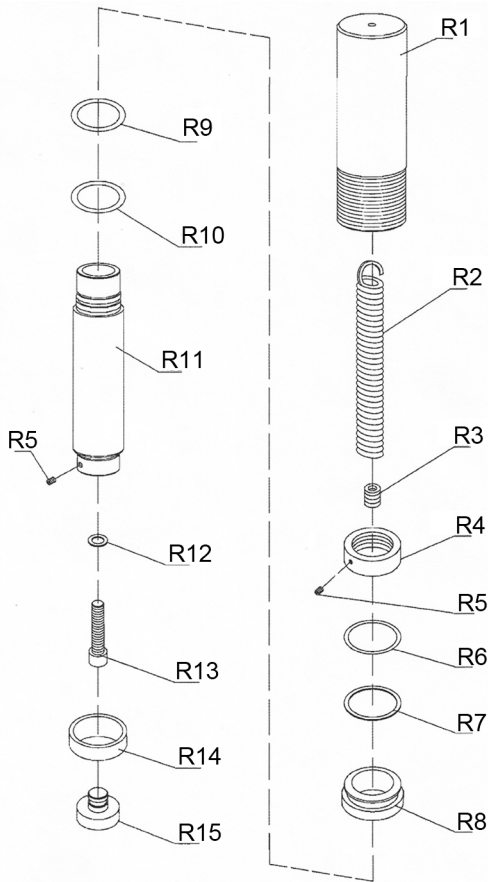

NO	DESCRIPTION
R1	Ram
R2	Spring
R3	Screw
R4	Nut
R5	Screw
R6	O-ring
R7	PTFE Washer
R8	Piston End

NO	DESCRIPTION
R9	O-Ring
R10	PTFE Washer
R11	Piston Rod
R12	Washer
R13	Screw
R14	End Ring
R15	Serrated Saddle



# PUMP PARTS DIAGRAM

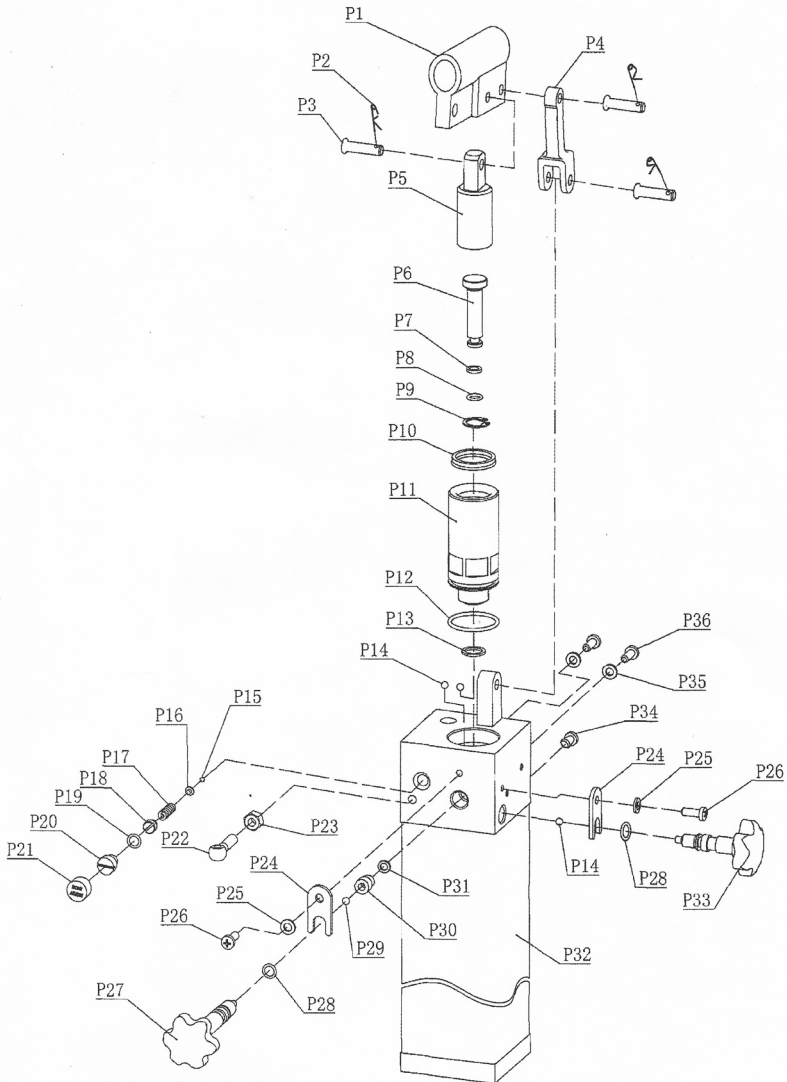

## PUMP PARTS LIST

NO	DESCRIPTION
P1	Handle Socket
P2	R-clip
P3	Clevis Pin
P4	Connecting Rod
P5	Piston
P6	Piston
P7	Nylon Ring
P8	PTFE Washer
P9	Retaining Ring
P10	Sealing Ring
P11	Piston Seat
P12	O-Ring
P13	Washer
P14	Ball
P15	Ball
P16	Ball Seat
P17	Spring
P18	Screw

NO	DESCRIPTION
P19	O-Ring
P20	Screw
P21	Dust Cap
P22	Bolt
P23	Nut
P24	U-type limiter
P25	Washer
P26	Screw
P27	Long Release Valve
P28	O-Ring
P29	Ball
P30	Release Seat
P31	Washer
P32	Pump
P33	Short Release Valve
P34	Oil Filter
P35	Washer
P36	Screw

# DECLARATION OF CONFORMITY



**Clarke**<sup>®</sup>  
**INTERNATIONAL**

Hemnall Street, Epping, Essex CM16 4LG

## DECLARATION OF CONFORMITY

This is an important document and should be retained.

We hereby declare that this product(s) complies with the following directive(s):

2006/42/EC Machinery Directive.

The following standards have been applied to the product(s):

BS EN1494:2000+A12008, EN ISO12100:2010.

The technical documentation required to demonstrate that the product(s) meet(s) the requirement(s) of the aforementioned directive(s) has been compiled and is available for inspection by the relevant enforcement authorities.

The CE mark was first applied in: 2014

**Product Description:** 30 & 50 Tonne Floor Shop Press  
**Model number(s):** CSA30FP/CSA50FP  
**Serial / batch Number:** N/A  
**Date of Issue:** 30/03/2016

Signed:

J.A. Clarke  
Director

# A SELECTION FROM THE VAST RANGE OF

# Clarke®

## QUALITY PRODUCTS

### AIR COMPRESSORS

From DIY to industrial, Plus air tools, spray guns and accessories.

### GENERATORS

Prime duty or emergency standby for business, home and leisure.

### POWER WASHERS

Hot and cold, electric and engine driven - we have what you need

### WELDERS

Mig, Arc, Tig and Spot. From DIY to auto/industrial.

### METALWORKING

Drills, grinders and saws for DIY and professional use.

### WOODWORKING

Saws, sanders, lathes, mortisers and dust extraction.

### HYDRAULICS

Cranes, body repair kits, transmission jacks for all types of workshop use.

### WATER PUMPS

Submersible, electric and engine driven for DIY, agriculture and industry.

### POWERTOOLS

Angle grinders, cordless drill sets, saws and sanders.

### STARTERS/CHARGERS

All sizes for car and commercial use.



**PARTS & SERVICE: 0208 988 7400**

**E-mail: [Parts@clarkeinternational.com](mailto:Parts@clarkeinternational.com) or [Service@clarkeinternational.com](mailto:Service@clarkeinternational.com)**

**SALES: UK 01992 565333 or Export 00 44 (0)1992 565335**

**Clarke® INTERNATIONAL** Hemnall Street, Epping, Essex CM16 4LG  
[www.clarkeinternational.com](http://www.clarkeinternational.com)