

Clariflo® STRONG-ARM



HYDRAULIC MOTORCYCLE LIFT

MODEL NO: CML5

PART NO: 7610193

OPERATION & MAINTENANCE INSTRUCTIONS



LS0713

INTRODUCTION

Thank you for purchasing this CLARKE hydraulic motorcycle lift.

Before attempting to operate this product, it is essential that you read this manual thoroughly and carefully follow all instructions given. In doing so you can look forward to the product giving you long and satisfactory service.

GUARANTEE

This CLARKE product is guaranteed against faulty manufacture for a period of 12 months from the date of purchase. Please keep your receipt as proof of purchase.

This guarantee is invalid if the product is found to have been abused or tampered with in any way, or not used for the purpose for which it was intended.

Faulty goods should be returned to their place of purchase, no product can be returned to us without prior permission.

This guarantee does not effect your statutory rights.

SPECIFICATIONS

Model Number	CML5
Maximum Load	680 kg
Minimum Table Height	135 mm
Maximum Table Height	430 mm
Overall Length (inc handle)	1200 mm
Overall Width	390 mm
Weight	37.5 kg

SAFETY PRECAUTIONS

1. **ALWAYS** work in accordance with the instruction handbook;
2. **NEVER** exceed the maximum safe working load of 680 kg, and only use the motorcycle lift for its intended purpose.
3. **NEVER** use the lift if it has been subjected to an abnormal load or shock. It should be removed from service immediately and fully inspected by qualified personnel, and passed as serviceable, before being used again.
4. **NEVER** rely upon the hydraulic ram to support the saddle when loaded. Always use the locking bar to hold the saddle in one of the positions provided.
5. **ALWAYS** use the lift on a solid, flat, level surface.
6. **ALWAYS** screw down the stabilisers before putting the saddle under load.

NOTE: *The castors are not designed to take the weight of the motorcycle, but are used merely to move the lift quickly and easily around the workshop. On no account must you raise a loaded platform unless the stabilisers are screwed down, and NEVER use the lift to transport a load.*

7. **ALWAYS** use appropriate safety equipment, such as protective footwear, when using this lift.
8. **ALWAYS** inspect the lift before use to ensure it is in good condition, and replace any damaged or worn parts.
9. **ALWAYS** use spare parts supplied by Clarke International. Using non-standard parts could be extremely dangerous.
10. **ENSURE** the operator is trained in both operational and safety aspects.
11. **NEVER** leave this lift unattended whilst there is a load on it.
12. **NEVER** allow children or bystanders anywhere near this lift whilst it is in use.
13. **NEVER** use this lift to lift people or animals.

UNPACKING

Check to ensure that no damage has occurred during transit. Any damage should be reported to your Clarke dealer immediately.

The following should be included:

1 x Main frame assembly	1 x Lifting pedal
1 x T - Handle assembly and retaining pin	1 x Locking bar handle
1 x Hydraulic pump assy c/w lowering pedal	1 x Pair of ratchet straps

OVERVIEW

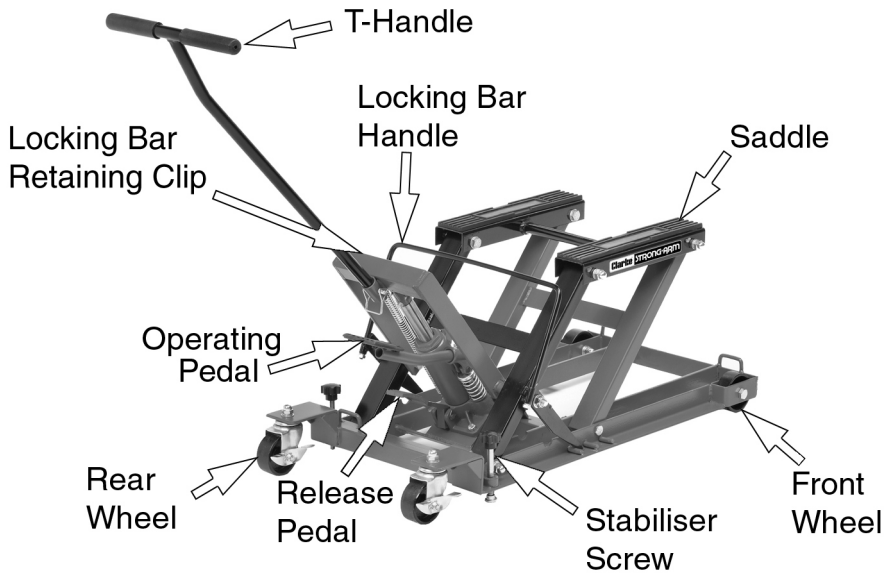

ASSEMBLY

THE RAM ASSEMBLY

1. Secure the ram assembly to its baseplate using the two M8x25 bolts and M8 Spring washers supplied.
2. Tighten the bolts securely.

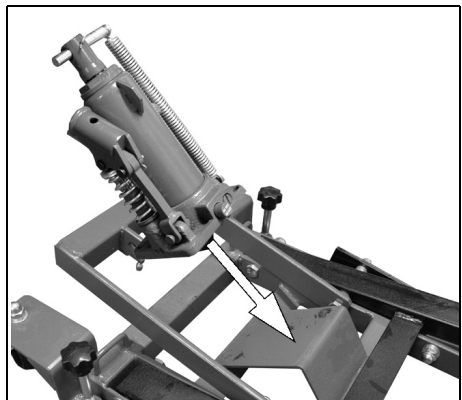

THE LOCKING BAR

1. Locate the locking bar handle in to the socket at each side of the lift.
2. Place a M8 spring washer on to the threads and screw on the M8 nut securely.
 - Ensure the locking bar is free to rotate under its own weight.
 - The locking bar should hinge so that the ends engage against one of the ridges on the base.

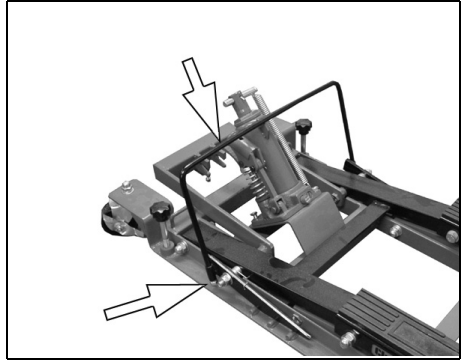

THE RAM TO THE FRAME

1. Lift the saddle manually and hook the ram frame over the ram as shown.
2. Secure in place using the locking screw.

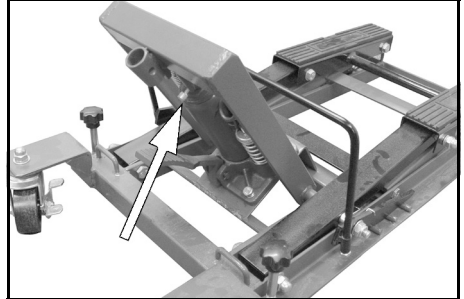
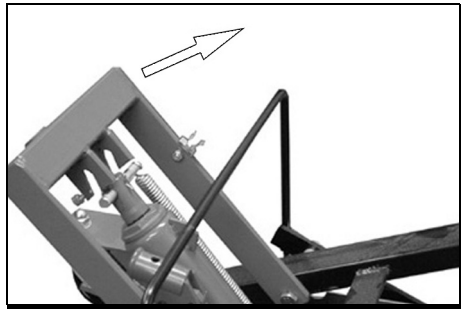

THE HANDLE AND OPERATING PEDAL

The handle is secured to the frame using the pin provided.

The operating pedal should be slid into place and secured using the M8x12 bolt supplied.

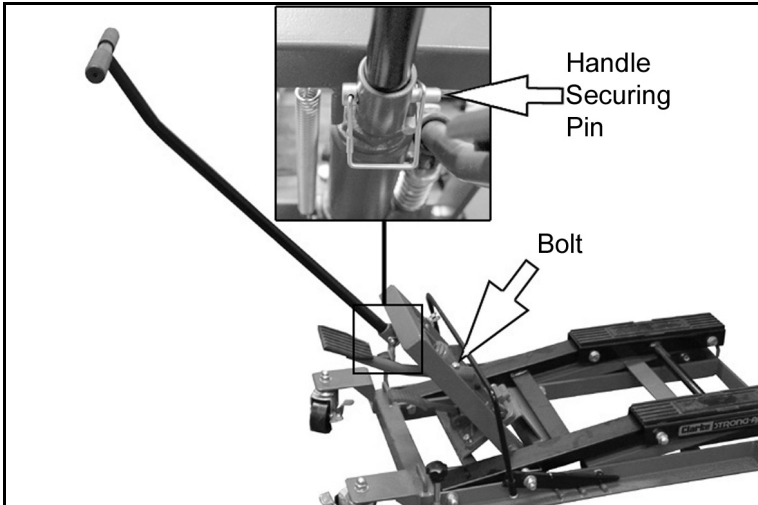

OPERATION

NOTE: The operator must be able to watch the lift and the load during all movements.

RAISING THE LOAD

1. Position the saddle between the wheels of the motorcycle, as near to the centre of gravity as possible.
2. Pump the operating pedal until the saddle makes light contact with the motorcycle frame, then assess where packing may be required to ensure the motorcycle is well supported and stable.

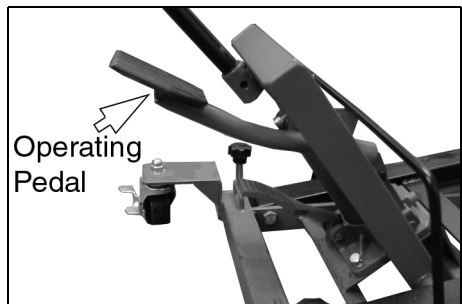

- When the motorcycle is satisfactorily supported and completely stable, screw down the two stabilisers,
 - This reduces any load from the castors,

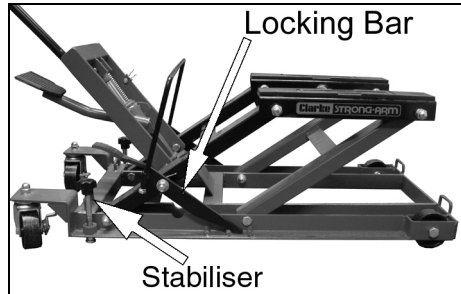

- Raise the load slowly by pumping the operating pedal.
- At all times make sure that the motor cycle is fully supported and stable.

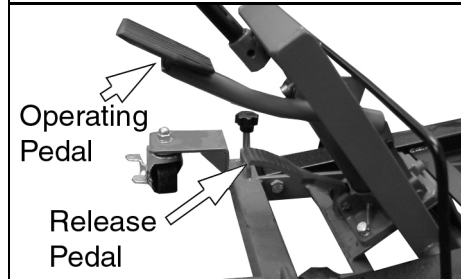

- Once you have reached the desired height, ensure the locking bar is engaged with the notches on the base,

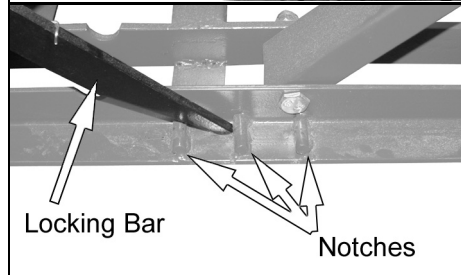

- Press the release pedal gently, allowing the saddle to lower until the load is taken by the locking bar.
 - Do not work under the raised load until it is secured using the locking bar.
- Secure the load using the supplied ratchet straps before you begin work.

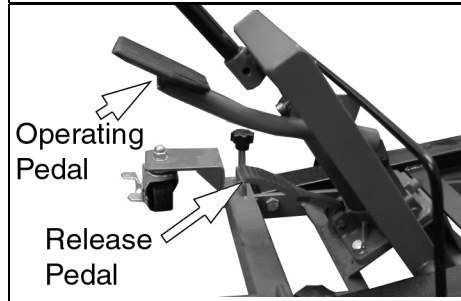

WARNING: UNDER NO CIRCUMSTANCES MUST YOU RELY UPON THE RAM TO SUPPORT THE LOAD.

WARNING: ENSURE THE MOTORCYCLE IS FULLY STABILISED BEFORE COMMENCING WORK.

LOWERING THE LOAD

1. Pump the operating pedal to raise the load slightly and release the locking bar.
2. Push the locking bar against the ram and into the locking bar retaining clip
3. Press down on the release pedal and allow the load to descend.
4. Remove the locking bar from the locking bar retaining clip before using the lift again.

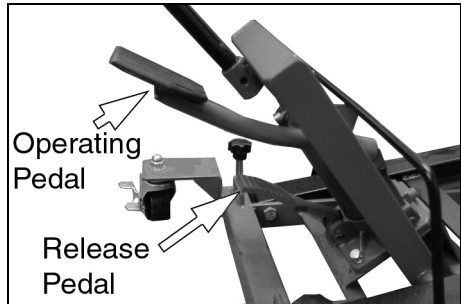

WARNING: TAKE GREAT CARE WHEN LOWERING. YOU ONLY NEED TO PRESS THE RELEASE PEDAL VERY LIGHTLY. TOO HEAVY A TOUCH WILL RESULT IN THE LOAD DESCENDING TOO RAPIDLY WHICH COULD BE HAZARDOUS

MAINTENANCE

BEFORE EACH USE

Visually inspect the lift for distortion of parts, cracked welds, damaged wheels or castors, oil leakage from the ram, or any other sign of damage. Should any of these be found, do not use the lift, and have it inspected and repaired by a qualified technician before putting back into use. If necessary, consult your Clarke dealer.

If any Warning labels becomes illegible, have it replaced. Contact your Clarke dealer.

REPAIR

Should any repairs be required they should be carried out by qualified service engineers, contact the Clarke Service department on 020 8988 7400.

PARTS LIST

MAIN UNIT

ITEM No	DESCRIPTION	PART NUMBER	ITEM No	DESCRIPTION	PART NUMBER
A	Base	HTCML5A	L	Pump Spring	HTCML5L
B	Link	HTCML5B	M	Lock Rear Castor Assembly	HTCML5M
C	Lift Saddle	HTCML5C	N	Height Lock Bar	HTCML5N
D	Height Lock Release	HTCML5D	O	Front Wheel Assembly	HTCML5O
E	Connecting Rod	HTCML5E	P	Loops	HTCML5P
F	T - Handle	HTCML5F	Q	Clip	HTCML5Q
G	Locking Screw	HTCML5G	R	Height Lock Springs	HTCML5R
H	Return Spring	HTCML5H	S	Lock Position Ridge	HTCML5S
I	Hydraulic Ram	HTCML5I	T	Rubber Pads	HTCML5T
J	Foot Pedal	HTCML5J	U	Oil Fill Plug	HTCML5U
K	Release Pedal	HTCML5K			

HARDWARE BOX

1	Spring Nut	Sold as 1 Kit HTCML5KIT
2	Nut M8	
3	Cotter Pin	
4	Bolt M8 x 12	
5	Bolt M8 x 25	
6	Washer	
7	Bolt M6 x 15	
8	Ratchet Straps	

PART DIAGRAM

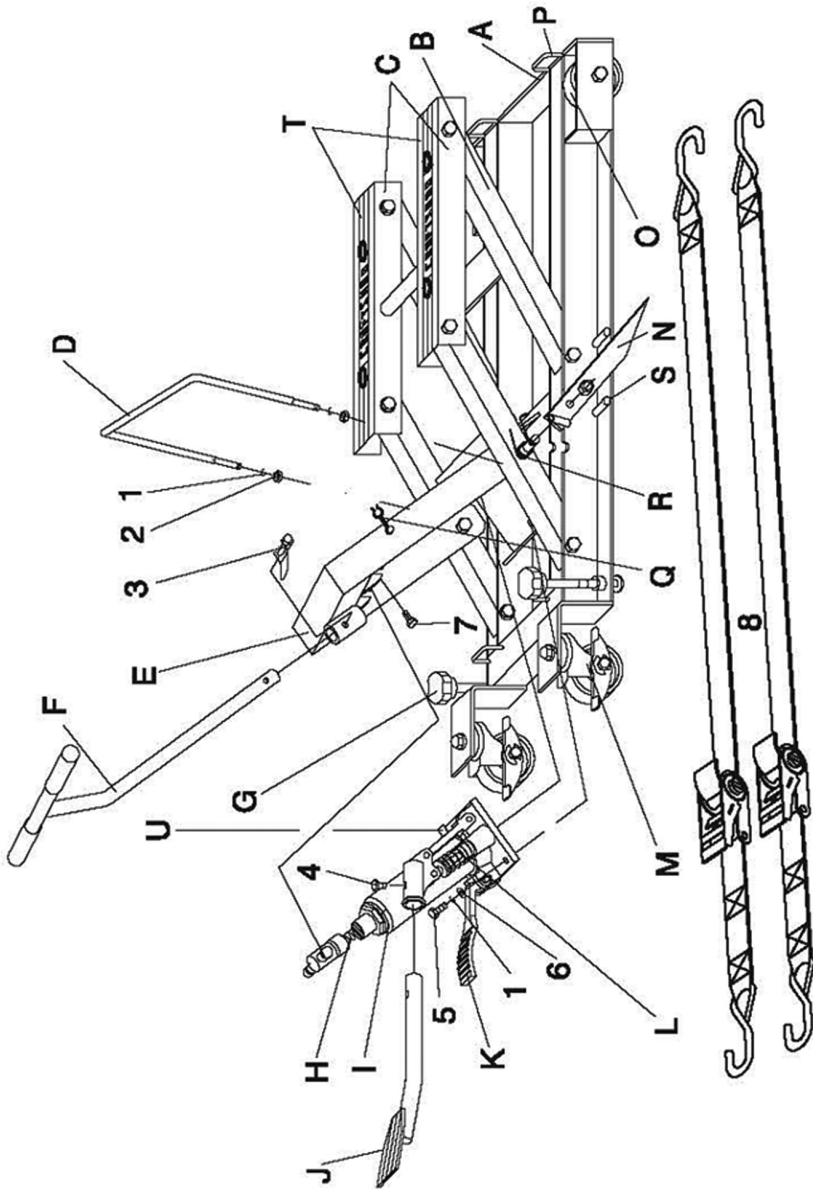

DECLARATION OF CONFORMITY



Clarke[®]
INTERNATIONAL

Hemnall Street, Epping, Essex CM16 4LG

DECLARATION OF CONFORMITY

This is an important document and should be retained.

We hereby declare that this product(s) complies with the following directive(s):

2006/42/EC Machinery Directive.

The following standards have been applied to the product(s):

EN 1493:1998 +A1:2008

The technical documentation required to demonstrate that the product(s) meet(s) the requirement(s) of the aforementioned directive(s) has been compiled and is available for inspection by the relevant enforcement authorities.

The CE mark was first applied in: 2010

Product Description: Hydraulic Motorcycle / ATV lift
Model number(s): CML5
Serial / batch Number: N/A
Date of Issue: 26/02/2013

Signed:

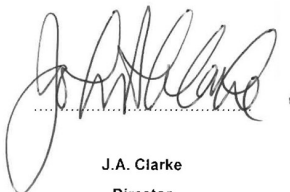

.....

J.A. Clarke
Director

A SELECTION FROM THE VAST RANGE OF

Clarke®

QUALITY PRODUCTS

AIR COMPRESSORS

From DIY to industrial, Plus air tools, spray guns and accessories.

GENERATORS

Prime duty or emergency standby for business, home and leisure.

POWER WASHERS

Hot and cold, electric and engine driven - we have what you need

WELDERS

Mig, Arc, Tig and Spot. From DIY to auto/industrial.

METALWORKING

Drills, grinders and saws for DIY and professional use.

WOODWORKING

Saws, sanders, lathes, mortisers and dust extraction.

HYDRAULICS

Cranes, body repair kits, transmission jacks for all types of workshop use.

WATER PUMPS

Submersible, electric and engine driven for DIY, agriculture and industry.

POWER TOOLS

Angle grinders, cordless drill sets, saws and sanders.

STARTERS/CHARGERS

All sizes for car and commercial use.



PARTS & SERVICE: 020 8988 7400
E-mail: Parts@clarkeinternational.com or Service@clarkeinternational.com
SALES: UK 01992 565333 or Export 00 44 (0)1992 565335

Clarke® INTERNATIONAL Hemnall Street, Epping, Essex CM16 4LG
www.clarkeinternational.com