

Clariflex®

STRONG-ARM



HYDRAULIC MOBILE LIFTING TABLE

MODEL NO: HTL300 & HTL500

PART NO: 7610148 & 76210152

OPERATION & MAINTENANCE INSTRUCTIONS

CE

ORIGINAL INSTRUCTIONS

GC1116

INTRODUCTION

Thank you for purchasing this CLARKE Mobile Hydraulic Lifting Table, designed for the quick and convenient raising of components or equipment in and around a workshop.

Before attempting to use this product, please read this manual thoroughly and follow the instructions carefully. In doing so you will ensure the safety of yourself and that of others around you, and you can look forward to your purchase giving you long and satisfactory service.

GUARANTEE

This product is guaranteed against faulty manufacture for a period of 12 months from the date of purchase. Please keep your receipt which will be required as proof of purchase.

This guarantee is invalid if the product is found to have been abused or tampered with in any way, or not used for the purpose for which it was intended.

Faulty goods should be returned to their place of purchase, no product can be returned to us without prior permission.

This guarantee does not effect your statutory rights.

TECHNICAL SPECIFICATIONS

	HTL300	HTL500
Part No	7610148	7610152
Maximum Safe working Load	300kg	500kg
Maximum Lifting Height	900 mm	
Minimum Lifting Height	340mm	
Dimensions	935x500x350mm (lowered)	
Weight	81 kg	90kg
Recommended Oil (conforming to ISO VG32)	YBN32 or equivalent	

SAFETY PRECAUTIONS



WARNING: THE USER MUST FOLLOW ALL INSTRUCTIONS WITHIN THIS INSTRUCTION MANUAL AND NOT OPERATE THE LIFTING TABLE UNTIL HAVING DONE SO.

THE LIFTING TABLE

1. The table must be maintained and repaired in accordance with the these instructions. Such maintenance and repair must be carried out by qualified persons and tested prior to returning to service.
2. Ensure that the lift table is in good working order. Have any damaged parts repaired or replaced immediately. Use genuine Clarke parts only. The use of unauthorised parts may be dangerous and will invalidate the guarantee.
3. Do not exceed the maximum safe working load of the table stated in the Technical Specification on page 2. Always ensure the load is evenly distributed across the table.
4. Never tamper with the lifting table or modify it in any way, as this could prove to be dangerous and will invalidate the guarantee. Only use the product for the purpose for which it is intended.
5. Do not use if an oil leak is apparent. Consult your Clarke dealer.
6. Check the condition of the labels regularly and replace as required. Labels are provided in accordance with BSEN1570.

THE WORKPLACE

1. Only use in a suitable, well lit work area.
2. Keep the work area clean and tidy and free from unrelated items.
3. Use the lifting table on level and solid ground, preferably concrete. Avoid soft/unmade ground as the wheels may sink in. Excessive force may be invited to move the table if floor conditions are poor.
4. Use appropriate safety equipment, such as protective footwear, when using this product.

DURING OPERATION



1. Never climb on, or attempt to ride on the lifting table.
2. Never use the lifting table for lifting, lowering or transporting persons.
3. Never transport a load in the raised position.

4. Never allow hands or feet to be placed under the platform within the range of movement of the scissor lift components. Take care not to trap fingers in the moving parts.
5. Always ensure when lifting, that all parts of the load can be clearly seen.
6. Always ensure the load is centralised on the table and is completely stable before lifting or moving. DO NOT secure by hand alone, use securing straps where necessary.
7. Always apply the brakes before lifting or lowering, when the lift is left unattended, or when stationary on an incline.
8. Always ensure the lift table is left in its FULLY LOWERED position when not in use.
9. Take all necessary precautions when handling heavy equipment. Be aware that moving equipment of 300 or 500 kgs can be hazardous. The load MUST be adequately secured when the table is moved.
10. Be aware that force may be required to move a load of 300 or 500 kg. Take all safety precautions when moving and stopping to ensure it is carried out under complete control.
11. Be aware of what is happening in the immediate vicinity, and anticipate possible hazards...blind corners, overhead obstructions etc. Take great care when lowering a load, that the hands are not trapped by the load.

LIFTING OPERATIONS AND LIFTING EQUIPMENT REGULATIONS 1998

This lifting table, depending on use, may fall within the scope of LOLER. It is the owner's responsibility to determine whether or not it does, and if so, to comply with any applicable requirements. It may be necessary to have the product regularly inspected.

SAFETY SYMBOLS

	<p>Read instruction manual before use</p>		<p>Do not stand on platform</p>
	<p>Do not put hands or feet under platform</p>		

The above safety symbols appear on the product.

BEFORE USE

UNPACKING

Obtain the assistance of a second person when unpacking the lifting table from its packaging. Alternatively, cut and fold down one end of the box and wheel the lifting table out.

ASSEMBLY

Lower the handle into the holes in the frame and secure each side from below with the bolt (64), spring, and flat washers (63 & 62), provided.

Insert the foot operating lever (59) into its socket at the end of the connecting bar (60). Insert the bolt (42) and secure with washers (6 & 11) and nut (12).

PURGING AIR BUBBLES

During shipment, air bubbles can occur in the hydraulic system which may cause the ram to feel “spongy” and it may not achieve its maximum lift.

1. Hold the release lever and pump the operating lever several times to purge any air from the hydraulic system.
2. Pump the operating lever to raise the table fully, then pull the release lever to lower the table and check that it descends to its lowest position.

The lifting table is now ready to use.

OPERATION

Before raising or lowering the table:

1. Check for any damage or worn parts. **Do not use the lifting table unless it is perfectly serviceable.**
2. Lock the castor brakes before loading the table. (A brake is provided on each castor for safety).
3. Ensure the load is completely stable and evenly spread on the table and secured if necessary.
4. Ensure that no obstacles can snag or prevent the table from being raised.

RAISING A LOAD



WARNING: BEFORE LIFTING, ENSURE THE SAFETY PRECAUTIONS ARE STRICTLY FOLLOWED. NO RESPONSIBILITY CAN BE ACCEPTED FOR INCORRECT USE OF THE TABLE.

1. Pump the foot lever (59) until the table reaches the desired height. (The release lever (65) is spring loaded to return it to its closed position).

SAFETY BARS ('A' FIG.1)

IMPORTANT: When working with the table raised, the safety support bars must be put in place and the table lowered so that the load is supported by the safety bars and not by the hydraulic ram, as shown in the illustration. The safety bars are secured with a clip, one to each leg of the lift.

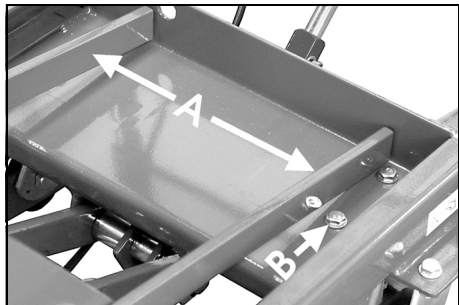

2. Make one final check to ensure that there are no obstructions to lifting and that all personnel are well clear before continuing to pump the handle and lift the load.

LOWERING THE LOAD

1. Slowly pull the release lever (65) upwards. Ensure the load is lowered in a fully controlled manner - do not jerk the lever upwards.
 - Releasing the lever will cause the table to stop at any desirable height.

NOTE: This operation must be done very slowly and in full control. DO NOT let the load lower suddenly, this could damage internal components.

NOTE: Take care to ensure when lowering, that the safety bars do not foul the bolt heads shown at B.

MAINTENANCE

DAILY/BEFORE USE

Inspect the lift table for signs of obvious damage, distortion of components, damage to castors etc.

Check the ram for signs of hydraulic oil leakage.

If any of the above are apparent - DO NOT use the table lift. Have it inspected by a qualified person and repaired if necessary.

NOTE: Be aware that oil leaks can produce extremely hazardous environmental conditions. All leaks must be cleaned immediately and sand/sawdust or similar absorbent material should cover the contaminated area (which should be isolated), until it is completely cleaned and dried.

MONTHLY

1. Check that all joints and pivots are clean and moving freely. Lubricate all pivots with light oil.
2. Check the action of the hydraulic ram and inspect for leaks. If leaks are apparent, DO NOT USE THE LIFTING TABLE, but submit for repair. (Contact your Clarke dealer). Always make every effort to contain any escape of oil and prevent ingress into the local water course.
3. The hydraulic system may be topped up with any commonly available hydraulic oil such as Clarke hydraulic oil (part number 3050830).
4. Check castor brake action and ensure that the table lift is held securely when they are applied.
5. Remove any corrosion and repaint for protection.
6. Check the piston rod periodically for signs of corrosion. Clean exposed areas with a clean oiled cloth.
7. Ensure that labels and warning notices are in place and legible.
8. Inspect for distortion of hinge pins and security of all nuts and bolts.
9. Keep all moving parts lightly lubricated to prevent corrosion.

10. In the case of a persistent oil leak which requires the dismantling of the hydraulic parts to correct, the lift table should be taken to your Clarke dealer for overhaul.

NOTE: ALL major repairs MUST be re-tested according to BSEN1570:- ANNEX C regulations and should therefore be carried out by your CLARKE dealer.

TROUBLESHOOTING

PROBLEM	CAUSE	SOLUTION
Table will not operate or lifting height is insufficient.	<ol style="list-style-type: none"> 1. Non-return valve steel ball (23) is not seated 2. Pin (28) bears heavily on steel ball 3. Insufficient hydraulic oil. 	<ol style="list-style-type: none"> 1. Clean valve hole and replace ball 2. Adjust cable (2) at the adjuster (3&4) so that free play exists between ball and pin. 3. Top up oil to correct level
Platform rises then sinks	<ol style="list-style-type: none"> 1. Non-return valves (23, 24, 16), not seated correctly 2. As (2) above 	<ol style="list-style-type: none"> 1. Clean valve holes and replace balls 2. As (2) above
Platform will not lower.	<ol style="list-style-type: none"> 1. Control valve may be faulty. 2. Non-return valves (23, 24,16), not seated correctly 3. As (2) above 	<ol style="list-style-type: none"> 1. Clean valve holes and replace balls 2. As (2) above 3. Return to your Clarke dealer for repair
Oil leak at pin (28)	O-rings (29) damaged	Return to your Clarke dealer for repair
Oil leak at pump element (5) and piston rod (44)	Seal rings (1, 3, 47, & 48) are damaged	Return to your Clarke dealer for repair

If any of these remedies fail to restore your lift table, consult your Clarke dealer

STORAGE

Store in a dry place with the ram fully lowered to minimise ram and piston corrosion. If stored for long periods, inspect at least once a year, clean and re-oil. For servicing, contact your CLARKE dealer, or CLARKE International Service Department.

DECOMMISSIONING THE PRODUCT

Should the product become completely un serviceable and require disposal, draw off the oil into a suitable container and dispose of the product and the oil at an approved recycling centre, according to local regulations.

Take care to ensure that any spilled hydraulic oil is cleaned away using sand, or treated with absorbent granules designed for the purpose.

Always make every effort to contain any spillage and prevent ingress into the local water course.

This product contains valuable raw materials. At the end of the products life all materials should be taken to a recycling centre for disposal and re-use.

HYDRAULIC RAM COMPONENT PARTS

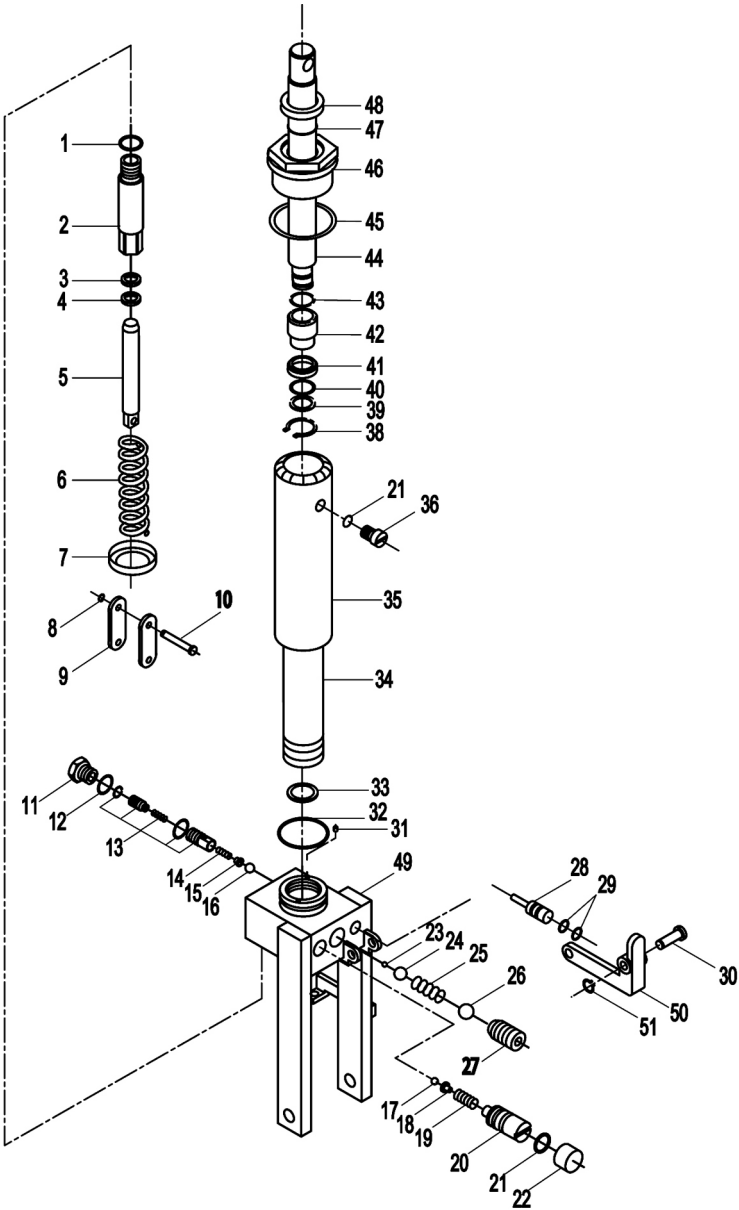

HYDRAULIC RAM COMPONENT PARTS

PART NO	DESCRIPTION	PART NO	DESCRIPTION
1	O-ring 22x2.65	27	Screw
2	Pump Cylinder (HTL300 or 500)	28	Strike Pin
3	Sealing Ring (HTL300 or 500)	29	O-ring 6.9x1.8
4	Dust Ring (HTL300 or 500)	30	Shaft
5	Pump Plunger (HTL300 or 500)	31	Filter
6	Spring	32	O-ring 65x3.55
7	Spring Seat	33	Sealing Ring
8	Circlip	34	Cylinder
9	Joint Plate	35	Housing
10	Pin	36	Screw
11	Plug	37	n/a
12	Copper Washer	38	Circlip
13	Damping Valve	39	Washer
14	Spring	40	O-ring 33.5x3.55
15	Spring Seat	41	Cup Packing
16	Steel Ball	42	Bush
17	Steel Ball	43	O-ring 20x2.65
18	Spring Seat	44	Piston Rod
19	Spring	45	Sealing Ring
20	Adjusting Screw	46	Cylinder Cap
21	O-ring 7.5x2.65	47	O-ring 31.5x3.55
22	Cover Ring	48	Rubber Seal
23	Steel Ball	49	Base
24	Steel Ball	50	Lever Plate
25	Spring	51	Circlip
26	Steel Ball		

TABLE & FRAME COMPONENT PARTS

PART NO	DESCRIPTION	PART NO	DESCRIPTION
1	Handlebar	36	L-Pin
2	Pull Rod	37	Screw
3	Nut	38	Pin
4	Screw	40	Inner Lifting Arm (HTL300 or 500)
5	Bolt	41	Cushion
11	Washer	42	Bolt
12	Washer	43	Circlip
15	Nut	44	Washer
16	Washer	45	Roller
17	Swivelling Caster Wheel	46	Washer
18	Frame	47	Pedal Bar
19	Axle	48	Roller
20	Cover	49	Circlip
21	Washer	50	Washer
22	Screw	51	Safety Support Bar
23	Bearing	59	Protective Cover
24	Wheel	60	Connecting Bar
25	Circlip	61	Table
29	Hydraulic Pump Assembly	62	Washer
30	Short Shaft	63	Washer
31	Bush	64	Nut
32	Circlip	65	Release Handle
33	Short Shaft	66	Pin
34	Circlip	67	Mesh Guard
35	Bush	68	Outer Lifting Arm (HTL300 or 500)

TABLE & FRAME COMPONENT PARTS

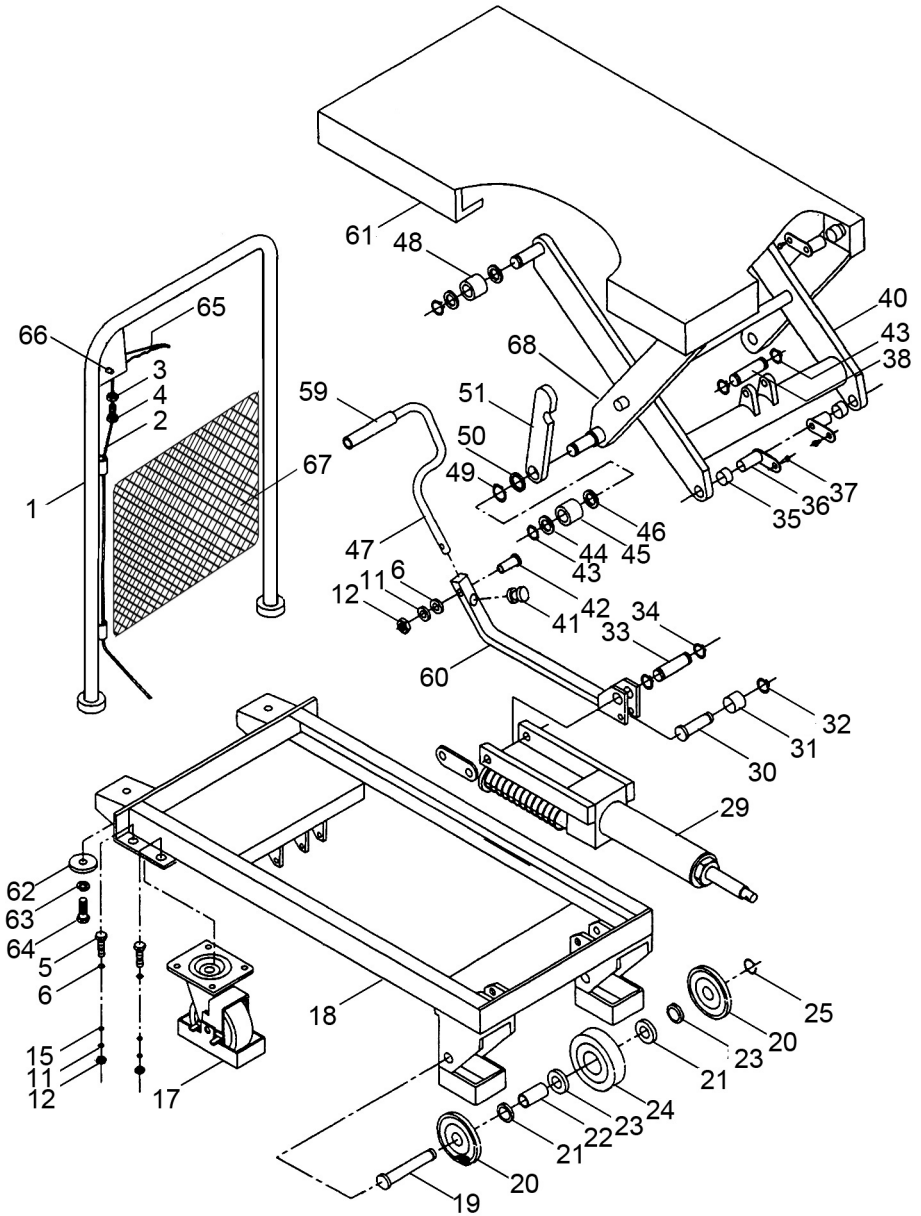

DECLARATION OF CONFORMITY



Clarke[®]
INTERNATIONAL

Hemnall Street, Epping, Essex CM16 4LG

DECLARATION OF CONFORMITY

This is an important document and should be retained.

We hereby declare that this product(s) complies with the following directive(s):

2006/42/EC Machinery Directive.

The following standards have been applied to the product(s):

EN1570-1:2011.

The technical documentation required to demonstrate that the product(s) meet(s) the requirement(s) of the aforementioned directive(s) has been compiled and is available for inspection by the relevant enforcement authorities.

The CE mark was first applied in: 2004

Product Description: Hydraulic Lifting Tables
Model number(s): HTL 300 / HTL 500
Serial / batch Number: -
Date of Issue: 10/10/2016

Signed:

J.A. Clarke
Director

A SELECTION FROM THE VAST RANGE OF

Clarke®

QUALITY PRODUCTS

AIR COMPRESSORS

From DIY to industrial, Plus air tools, spray guns and accessories.

GENERATORS

Prime duty or emergency standby for business, home and leisure.

POWER WASHERS

Hot and cold, electric and engine driven - we have what you need

WELDERS

Mig, Arc, Tig and Spot. From DIY to auto/industrial.

METALWORKING

Drills, grinders and saws for DIY and professional use.

WOODWORKING

Saws, sanders, lathes, mortisers and dust extraction.

HYDRAULICS

Cranes, body repair kits, transmission jacks for all types of workshop use.

WATER PUMPS

Submersible, electric and engine driven for DIY, agriculture and industry.

POWERTOOLS

Angle grinders, cordless drill sets, saws and sanders.

STARTERS/CHARGERS

All sizes for car and commercial use.

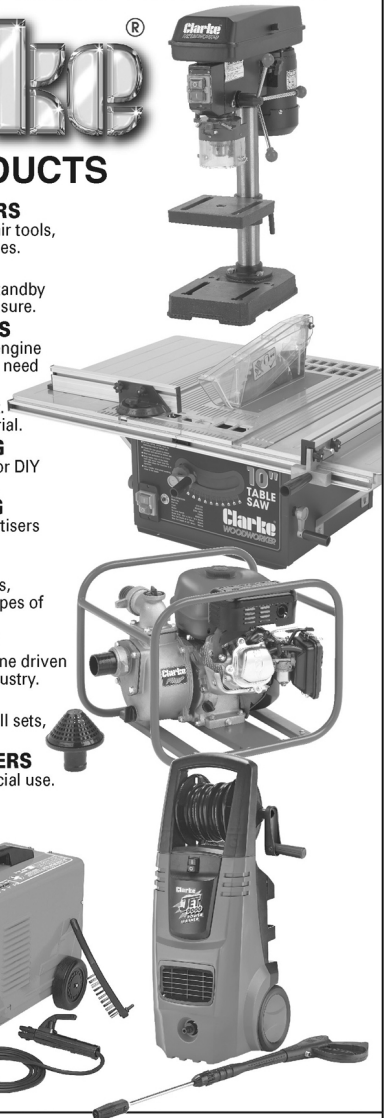

PARTS & SERVICE: 0208 988 7400

E-mail: Parts@clarkeinternational.com or Service@clarkeinternational.com

SALES: UK 01992 565333 or Export 00 44 (0)1992 565335

Clarke® INTERNATIONAL Hemnall Street, Epping, Essex CM16 4LG
www.clarkeinternational.com