

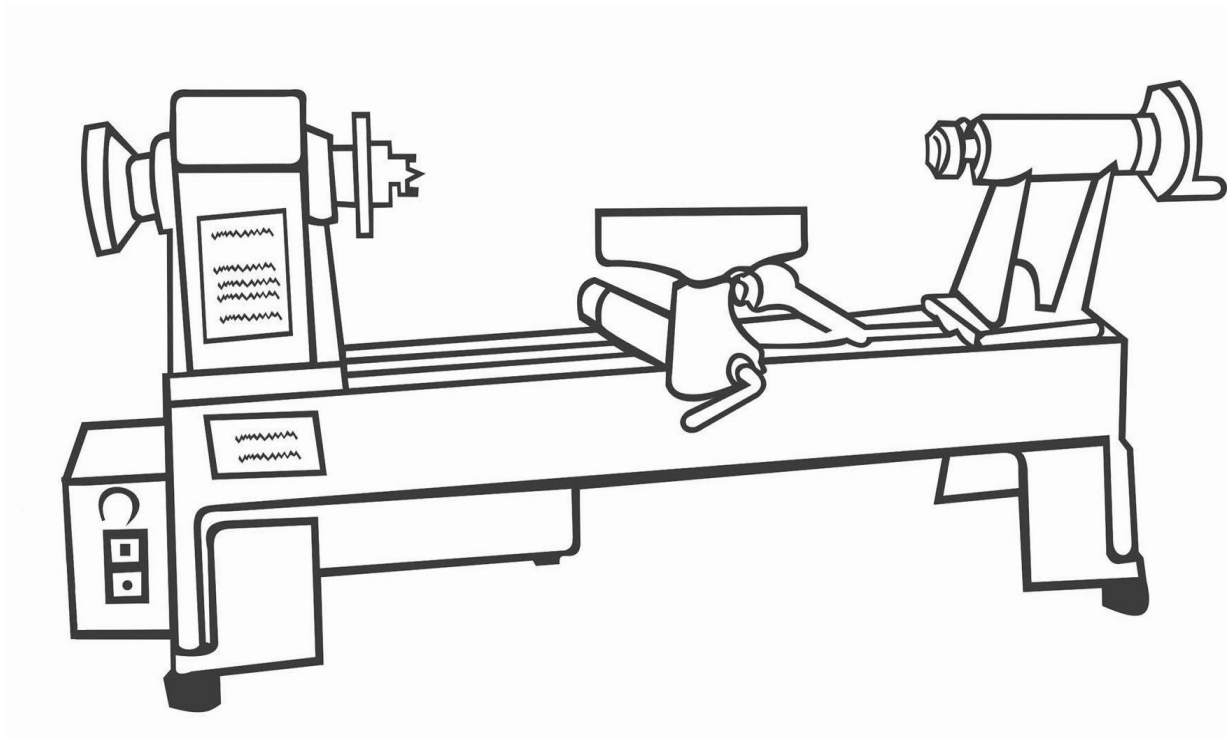

01936

# Variable Speed Cast Iron Midi Wood Lathe



*Please read and fully understand the instructions in this manual before operation.*

*Keep this manual safe for future reference.*

## Technical Data

Input voltage	230v ~ 50Hz
Motor	550w
Speed range	500 - 3500 RPM
Distance between centres	432mm
Turning capacity	305 mm

## General Safety Rules

**Safety is a combination of common sense, staying alert and knowing how your wood lathe works.**

**WARNING: TO AVOID MISTAKES THAT COULD CAUSE SERIOUS INJURY,  
DO NOT PLUG THE WOOD LATHE IN UNTIL THE FOLLOWING STEPS  
HAVE BEEN READ AND UNDERSTOOD**

1. READ and become familiar with this entire instruction manual. Learn the tool's applications, limitations, and possible hazards.
2. AVOID DANGEROUS CONDITIONS. DO NOT use power tools in wet or damp areas or expose them to rain. Keep work area well lit.
3. DO NOT use power tools in the presence of flammable liquids or gases.
4. ALWAYS keep your work area clean, uncluttered and well lit. DO NOT work on a floor surface that is slippery with sawdust, wax or similar.
5. KEEP BYSTANDERS AT A SAFE DISTANCE FROM the work area especially when tool is operating. NEVER allow children near the tool.
6. DO NOT FORCE THE TOOL to do a job for which it was not designed.
7. DRESS FOR SAFETY. DO NOT wear loose clothing, gloves, neckties, or jewelry (rings, watches) when operating tool. They can get caught and draw you into moving parts. ALWAYS wear non-slip footwear, and tie back long hair.
8. WEAR A FACE MASK OR DUST MASK. Wood lathe operation produces dust.

9. ALWAYS remove the plug from the electrical outlet when making adjustments, changing parts, cleaning or working on tool.
10. AVOID ACCIDENTAL START-UPS. Make sure that the power switch is in the "OFF" position before plugging in the power cord.
11. REMOVE ADJUSTING TOOLS. ALWAYS MAKE SURE all tools are removed from the wood lathe before turning it on.
12. NEVER STAND ON A TOOL. Serious injury could result if the tool tips or is accidentally hit DO NOT store anything above or near the tool.
13. NEVER LEAVE A RUNNING TOOL UNATTENDED. Turn the power switch to "OFF". DO NOT leave tool until it has come to a complete stop.
14. DON'T OVERREACH. Keep proper footing and balance at all times. Wear oil resistant rubber-soled footwear. Keep floor clear of oil scrap and other debris.
15. MAINTAIN TOOLS PROPERLY. ALWAYS keep tools clean and in good working order. Follow instructions for lubricating and changing accessories.
16. CHECK DAMAGED PARTS. Check for alignment of moving parts, binding of moving parts, breakage of parts, improper mounting or any other conditions that may affect the tools operation. Any part that is damaged should be properly repaired or replaced before use.
17. MAKE WORKSHOP CHILDPROOF. Use padlocks, master switches and ALWAYS remove starter keys where possible.
18. DO NOT operate tool if you are under the influence of any drugs, alcohol or medication that could affect your ability to use the tool properly.
19. WARNING. Dust penetrated from certain materials can be hazardous to your health. Always operate lathe in a well-ventilated area and provide for proper dust removal. Use dust collection systems whenever possible.

## Specific Safety Rules for the Wood Lathe

**WARNING: DO NOT OPERATE YOUR WOOD LATHE UNTIL IT IS COMPLETELY ASSEMBLED AND  
INSTALLED ACCORDING TO THE INSTRUCTIONS.**

1. For your own safety, read the entire instruction manual before operating the lathe.
2. ALWAYS wear eye protection.
3. Do not wear gloves, necktie, or loose clothing.
4. Tighten all locks before operating.
5. Do not mount a split work-piece.
6. Use the lowest speed when starting a new work-piece.
7. Read the warning label attached to the wood lathe.
8. When turning a work-piece, always rough the wood to round form at slow speed. If the lathe is run so fast that it vibrates, there is a risk that the work-piece will be thrown or the tool jerked from your hands.
9. Always rotate the work-piece by hand before turning on the motor. If the work-piece strikes the tool rest, it could split and be thrown out of the lathe.
10. Do not allow the turning tools to bite into the wood. The wood could split or be thrown from the lathe.
11. Always position the tool rest just above the centerline of the lathe when shaping a piece of stock.
12. Do not operate the lathe if it is rotating in the wrong direction. The work-piece must always be rotating toward you.
13. Before attaching a work-piece to the faceplate, always rough in out to make it as round as possible. This minimizes the vibrations while the piece is being turned. Always fasten the work-piece securely to the faceplate. Failure to do so could result in the work-piece being thrown from the lathe.
14. Position your hands so that they will not slip onto the work-piece.
15. Remove all loose knots in the stock before mounting it between the centers or on the faceplate.
16. Leave the work area only after the lathe's motor has come to a full stop.
17. Hang your turning tools on the wall beyond the tailstock end of the lathe. Do not lay them on the bench so that you must reach over the revolving work-piece to select them.
18. Keep a firm hold and remain in control of the cutting tool at all times. Take special precautions when shaping a section of stock in which knots or voids are found.
19. Always make safety come first.

# Operations / Adjustments

## Mounting & Changing Speed

The removable control box should be mounted onto the side of the lathe.

The mounting screws and washers etc. are included. The lathe is fitted with a 3-step pulley set-up along with the variable speed control which will allow for speeds ranging from 500 – 3500 rpm; See Speed Chart.

### Speed Chart

A = 650-1430 RPM  
B = 1240-2790 RPM  
C = 1600-3800 RPM

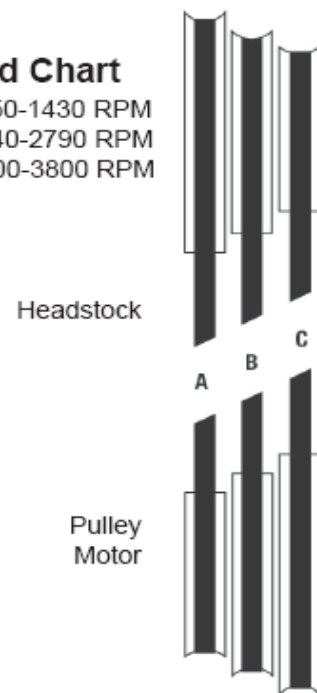

## Adjusting Belt Position

Make sure that the lathe is turned off or unplugged. Open the belt door on the headstock. Loosen the ratchet handle to allow the motor plate to swivel upwards. Swing the control box to the side for access to the motor pulley. To change the speed; move the drive belt from one pulley to another. **(NOTE: Always go from the larger Pulley to the smaller pulley).** After moving the belt, move down and tighten the motor pulley with the ratchet handle- this also tightens the belt. Turn your lathe's power on, and make sure that the belt is running consistently in its parallel groove. If all is smooth, turn the power off, re-attach the control box and the belt door to their original positions.

## Belt, Spindle & Bearing Replacement

*Refer to the Parts Diagram.*

To change the belt (#53), spindle (#14), or bearings (#4) for the lathe, you must first loosen the two set screws (#2) and hand wheel (#1). Next remove the upper access door (#7) and knob (#8). Loosen the set screw (#69) on the drive pulley (#25). Tap out the spindle using a mallet. If you do not have a mallet, place a block of wood against the spindle and tap with a hammer. To get the spindle completely out, use a flat head screwdriver to punch it the rest of the way. Be careful not to damage the bearings or the threads. Replace the bearings, spindle or belt as required.

**Belt:** You need only to move the spindle enough to slide a new belt on.

**Spindle:** You must knock the spindle completely out through both bearings.

**Bearings:** After removal of the spindle, completely - knock out the bearings from the inside of the headstock. This is best accomplished by inserting a long rod or screwdriver through one bearing inside the headstock toward the opposite bearing. Tap firmly to remove the bearing from the casting. Do the same for the second bearing. Please be aware not to damage the retainers (#13) when tapping out the bearing. Reassemble the new bearings by tapping them into place from the outside. Replace the spindle.

**Note:** You may have to loosen the ratchet handle (PARTS #44, #45, #46) to reinstall the spindle pulley (#52), spindle collar (#3), and belt (#53). Reinstall the hand wheel and set screws. **DO NOT** tighten the hand wheel against the bearings. Tighten the pulley set screw and close the access door.

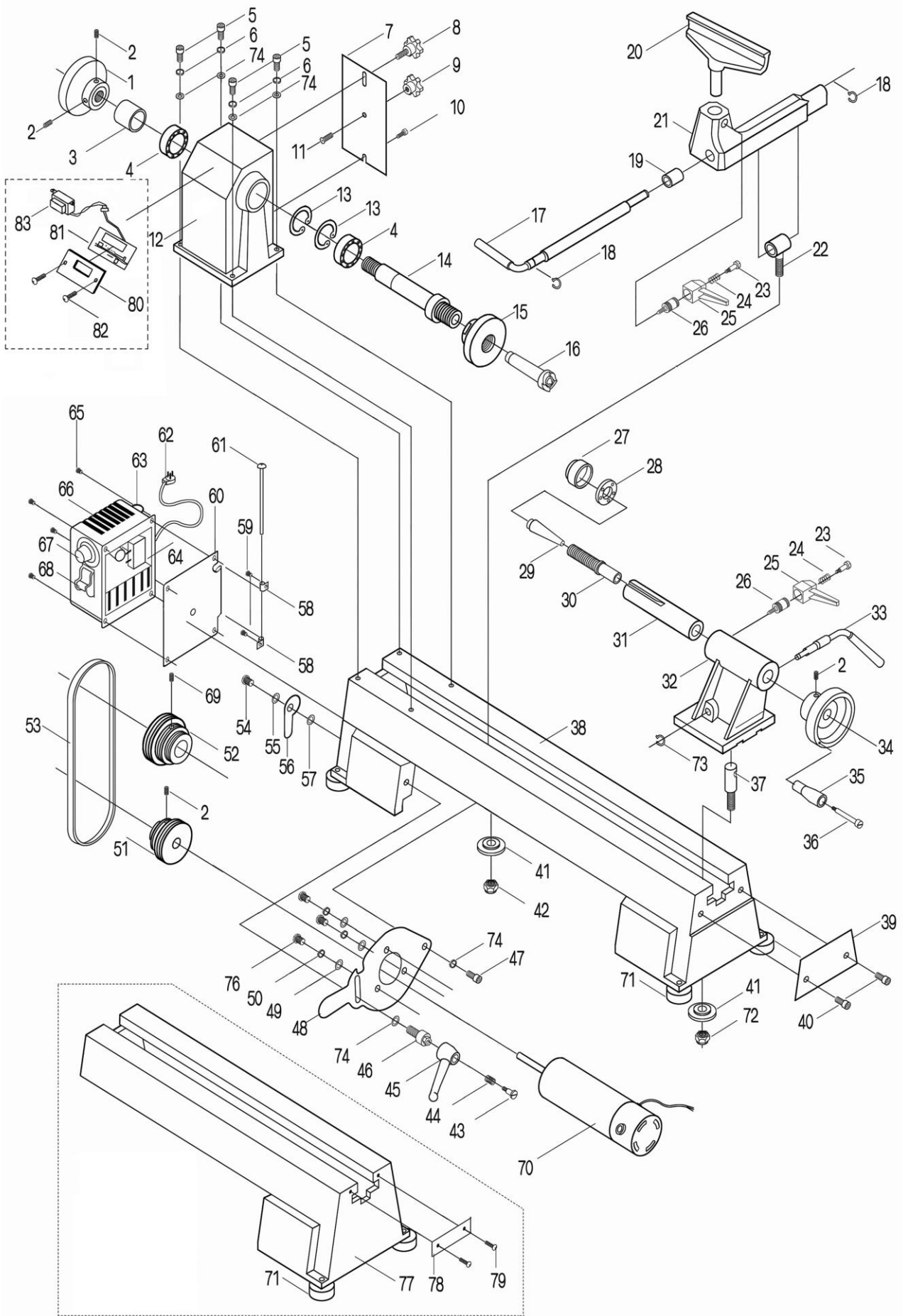

## PART LIST FOR DIAGRAM

NO.	DESCRIPTION	QTY
1	Hand Wheel	1
2	Hex Socket Screw M6×12	4
3	Collar Spindle	1
4	Ball Bearing 80105	2
5	Hex Socket Screw M8×25	4
6	Washer	6
7	Rear Belt Door	1
8	Moving Knob	1
9	Stationary Knob	1
10	Bolt	1
11	Semi-circle Head Screw	1
12	Headstock	1
13	Retaining Ring	2
14	Headstock Spindle	1
15	Face Plate	1
16	Headstock Spur Center	1
17	Lock Handle For Tool Rest Base	1
18	Retaining Ring 10	3
19	Tool Rest Bushing	1
20	Tool Rest (150mm ,300mm)	1
21	Tool Rest Base	1
22	Tool Rest Cam Follower	1
23	Flat Head Screw	2
24	Spring	2
25	Handle	2
26	Lock Bolt	2
27	Cup Center	1
28	Ball Bearing 80102	1
29	Taper Rod	1
30	Tailstock Quill	1
31	Tail Axis	1
32	Tailstock	1
33	Eccentric Axis	1
34	Quill Adjusting Wheel	1
35	Quill Crank Handle	1
36	Bolt	1
37	Cam Follower Tailstock	1
38	Bed	1

39	Retaining Plate	1
40	Hex Socket Screw M10×12	2
41	Lock Plate	2
42	Nut M10	2
43	Flat Head Screw	1
44	Spring Washer	1
45	Handle	1
46	Lock Screw	1
47	Hex Socket Screw M8×12	1
48	Motor Plate	1
49	Big Washer	3
50	Washer 6	3
51	Motor Pulley	1
52	Drive Pulley	1
53	Drive Belt	1
54	Bolt	1
55	Washer	1
56	Door Latch	1
57	Washer 4	1
58	Hinge	2
59	Semi-circle Head Screw M4×8	2
60	Switch-box Plate	2
61	Pin Hinge	1
62	Power Cord	1
63	Overload Protector	1
64	Line Board	1
65	Semi-circle Head Screw M4×6	4
66	Switch-box	1
67	Knob	1
68	Switch	1
69	Hex Socket Taper Screw M6×12	4
70	Motor	1
71	Rubber Washer	4
72	Nut M10	4
73	Retaining Ring	1
74	Washer	4
76	Flat Head Screw	3
77	Extension Bed	2
78	Plate	2
79	Screw	1
80	Cover	1
81	Variable Plate	1
82	Screw	2
83	Transformer	1



# DECLARATION OF CONFORMITY

## DECLARATION OF CONFORMITY

WE

SIP LTD

GELDERS HALL ROAD  
SHEPSHED  
LOUGHBOROUGH  
LEICESTERSHIRE  
LE12 9NH

Declare that the

Variable Speed Cast Iron Midi Wood Lathe SIP pt no 01936

Complies with the following EEC Directives:

2006/95/EC	Low Voltage Directive
2004/108/EC	EMC Directive
98/37/EC	Machinery Directive
2002/95/EC	ROHS Directive

And the relevant standards where applicable:

EN 61029-1+A12:2003  
EN 61029-2-3:1995  
EN 55014-1:2006  
EN 55014-2+A1:2001  
EN 61000-3-2:2006  
EN 61000-3-11:2000

Signed:



Director

Date: 05 January 2009





Please dispose of packaging for the product in a responsible manner. It is suitable for recycling. Help to protect the environment, take the packaging to the local amenity tip and place into the appropriate recycling bin.



Never dispose of electrical equipment or batteries in with your domestic waste. If your supplier offers a disposal facility please use it or alternatively use a recognised re-cycling agent. This will allow the recycling of raw materials and help protect the environment.

***FOR HELP OR ADVISE ON THIS PRODUCT PLEASE CONTACT YOUR DISTRIBUTOR.***