

CLARKE®



SECURITY LIGHT

MODEL NO: CL6PIR

PART NO: 4003535

OPERATION INSTRUCTIONS



GC0215

INTRODUCTION

Thank you for purchasing this CLARKE Security Light with motion sensor.

The motion sensor is a small electronic eye that detects infrared waves - heat waves that radiate from moving objects. When the sensor senses an object moving across its field of view, especially warmer objects such as people, animals and cars, it electronically turns on the light. The light stays on for a duration depending on how you set the timer. The sensor then automatically shuts the light off unless it continues to sense movement.

A photocell deactivates the light during daylight hours. The motion sensor has a semicircular field of view of up to 180 degrees and a distance range, adjustable by the sensitivity control. The sensor will react to the movement of animals, an approaching person, a passing car or sometimes wind-blown leaves.

Nuisance "trips," such as blowing leaves or a passing car, can cause the sensor to turn the light on when not required. However, you can eliminate most unwanted activation by adjusting the sensitivity setting and by carefully aiming the sensor to limit its field of view.

You can also narrow the field of view even more by applying adhesive tape to the sensor.

Before attempting to use this product, please read this manual thoroughly and follow the instructions carefully. In doing so you will ensure the safety of yourself and that of others around you, and you can look forward to your purchase giving you long and satisfactory service.

Keep these instructions in a safe place for future reference.

GUARANTEE

This product is guaranteed against faulty manufacture for a period of 12 months from the date of purchase. Please keep your receipt which will be required as proof of purchase.

This guarantee is invalid if the product is found to have been abused or tampered with in any way, or not used for the purpose for which it was intended.

Faulty goods should be returned to their place of purchase, no product can be returned to us without prior permission.

This guarantee does not effect your statutory rights.

ENVIRONMENTAL RECYCLING POLICY



Through purchase of this product, the customer is taking on the obligation to deal with the WEEE in accordance with the WEEE regulations in relation to the treatment, recycling & recovery and environmentally sound disposal of the WEEE.

In effect, this means that this product must not be disposed of with general household waste. It must be disposed of according to the laws governing Waste Electrical and Electronic Equipment (WEEE) at a recognised disposal facility.

SPECIFICATIONS

	CL6PIR
Voltage	230V -50Hz
Wattage	6W
Weighted Energy Consumption	6kWh/1000h
Efficiency	80 lm/w
EnergyEfficiency Class	A++, A+,A
Light Output (Lumens)	500
LED life expectancy	50,000 hours
Measured Light Output	1650 lux@300mm
Waterproof protection grade	IP44
Lens material	Tempered Glass
Light time duration	7 seconds min to 8 minutes max
Detection range	3 to 12 metres
Field of movement detection	180 deg
Weight	1.2 kg
Dimensions (L x W x H)	140 x 190 x 300 mm

SAFETY PRECAUTIONS

1. This unit must be installed to the requirements/wiring regulations of BS6761.
2. Before moving your security light or replacing a broken part, always ensure that the power supply is disconnected.
3. This unit must not be immersed in water.
4. Do not handle your security light to replace broken parts with wet hands, or when standing on a wet or damp surface or in water. Always ensure the power supply is disconnected at the mains.
5. Do not install this light in hazardous locations, such as flammable or explosive environments.
6. Do not look directly into the security light when switched on as this can damage the eyes.
7. A Residual Current Device (RCD) must be used in conjunction with your security light.
8. Do not use this security light if it has a broken lens, casing or damaged supply cable.
9. Always ensure that the front and the top of the security light is installed at a suitable distance from any flat or fixed surface. See Mounting the Light on page 5.
10. Please read all of the safety and operating instructions carefully before using this product. The following safety symbols may be found on the product.

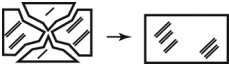
	Read this instruction booklet carefully before use.
	Always replace broken glass.

POSITIONING THE SECURITY LIGHT ON SITE

For best effect, the light should be positioned so that the motion sensor covers the approach to your doors and/or driveway and the light will come on when you come home at night. It can also be used to illuminate a patio or any potentially hazardous area such as stairways and swimming pools.

If improved security is a priority, position the light to cover all the approaches to your house, including gateways, patio doors, any darker areas, and around trees and bushes.

It is best to mount the light 2.5m above the ground and position it so that most personnel movement will occur from left to right, across the detection zone rather than moving directly toward the detector.

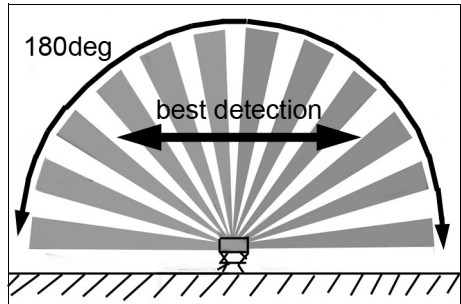

MOUNTING THE LIGHT

The unit can only be installed horizontally, not vertically, using its integral bracket. Do not mount the light to a ceiling.

The light is to be mounted so that the angle of inclination after adjustment is will aim the light beam at the ground within the 10m maximum range of the light.

Secure the fixing bracket to a wall or suitable structure with two screws or bolts at a minimum height of 2.5m.

The distance between the light and the area to be illuminated is to be at least 1m. In case you position the unit under a canopy, a minimum distance of 0.2m, measured from the top of the lamp to the under side of the canopy, is required.

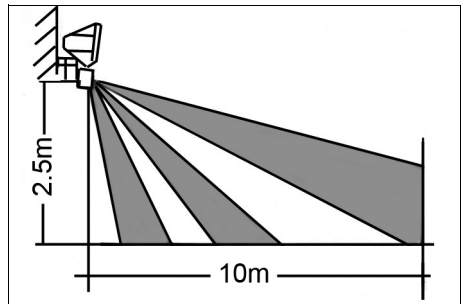

CONNECTING THE POWER CABLE

This security light is not supplied with an electric cable. It must be connected to a 220V - 240 VAC, 50 Hz power supply in accordance with the IEE Wiring Regulations BS7671.

In case of doubt during the installation, contact a qualified electrician.

The power cable should exit the building or other supporting structure in such a way as to line up with the security light and be able to pass through the central hole in the bracket as shown.

A drip loop should be left in the cable to prevent rainwater running into the lamp electrical compartment.

NOTE: Mounting holes are 70mm apart.

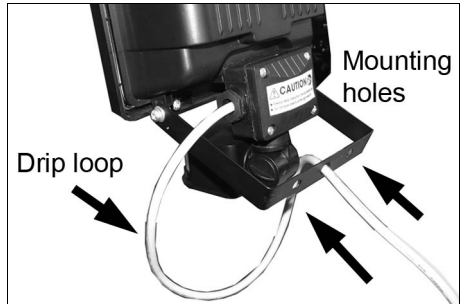

Wiring up this light should be carried out as follows:

1. Remove the cable gland and rubber washer from the cable inlet and retain.
 - The illustration shows the gland and washer removed.
2. Remove the terminal box cover by unscrewing the four securing screws.
3. Remove the screws securing the cable clamp.
4. Thread the cable gland, followed by the rubber washer over the cable, then thread the cable through the cable inlet in the junction box.
5. Carefully strip the outer insulation from the conductors for a distance of approx. 30mm taking care not to damage the conductor insulation.
6. Strip the conductor insulation, for a distance of approx. 8mm and twist the strands together, on each conductor.
7. Identify the terminals and connect the conductors accordingly as indicated on page 7. A = Blue (neutral), B = Brown (Live).
8. The earth wire (yellow/green) of the connection cable must be connected to the connection terminal, indicated with the earth symbol.

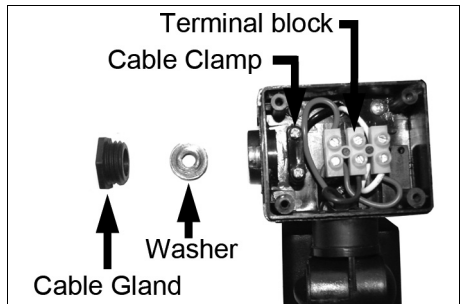

9. Replace the cable clamp, ensuring it firmly clamps the OUTER insulation, or sheathing, and NOT the conductors.
10. Push the rubber washer into the cable inlet and screw in the cable gland firmly. Do not overtighten as this could strip the plastic threads.
11. Before replacing the cover, ensure the terminal block is located snugly on the locating pegs as shown.

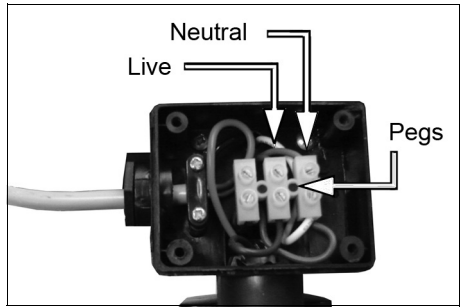

12. The cover should be firmly secured without over tightening the screws.
13. Connect the cable into a suitably protected electrical supply, ensuring the cable is secured to the building or otherwise restrained so as not to present a hazard.

SETTING THE ADJUSTMENTS

The activation light level, time and sensitivity can each be adjusted by twisting the control knobs below the motion sensor unit.

TESTING

The light can be adjusted to illuminate for any duration between 7 seconds to 8 minutes.

1. Turn the LUX control and the TIME control fully anticlockwise.
2. Set the SENS control to its mid-point.
3. Switch on the power and the light will turn on for about 2 minutes. Then it will turn off.
4. Walk through the detection area in front of the light. The light will turn on when you move and turn off when you stop. Wait for the light to turn off before moving again to test the sensor.
5. Adjust the motion sensor (SENS) to cover the desired detection area.
6. For a smaller coverage area, point the sensor down towards the ground; for a larger coverage area, aim the sensor farther away.

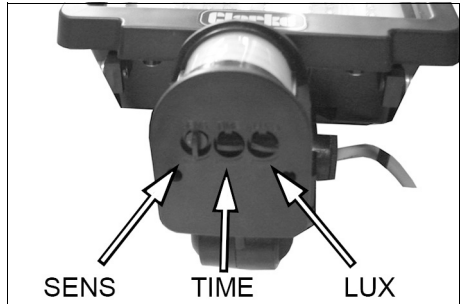

TIME ADJUSTMENT

The TIME adjustment controls how long the floodlight will stay on after movement has been detected.

1. Turn the TIME control knob clockwise to increase (up to about 8 minutes) how long the floodlights stay on or anti-clockwise to decrease the time delay (down to about 7 seconds).

LIGHT ADJUSTMENT

The LUX adjustment determines at what light level the light will start operating when you set the sensor to automatic operation.

1. Provisionally turn the LUX control knob to the clockwise limit at the moonlight (dusk) position.
 - In this provisional setting mode, the motion sensor remains inactive during daylight.

2. At dusk when you find the LUX level desired for operation, set the LUX control knob to the position that the motion sensor will become active as daylight declines.

SENSOR ADJUSTMENT

The sensitivity adjustment may be adjusted to compensate for seasonal variations in temperature and to reduce unwanted activation. The optimum sensitivity can be achieved by setting the SENS control knob initially to its mid-point and then adjusting the control knob clockwise to increase the detecting distance (up to 10 meters) or anti-clockwise to decrease the detecting distance (down to 3 meters).

ADJUSTING THE FIELD OF DETECTION

The field of detection of the infrared sensor can be adjusted 30 degrees in either horizontal or vertical direction. By means of horizontal adjustment, the permanent 180° field of detection can be infinitely directed to the right or left of the mounting position.

By vertical adjustment, the detection range can be reduced or lengthened. This can be used to reduce to incidence of unwanted activation caused by movements from neighbours and from the street.

The best sensing is achieved by approaching the field of detection perpendicular to its axis.

A delayed response is often obtained if the field of detection is approached along the direction of its axis.



POSSIBLE PROBLEMS

Boiler flues which may discharge vapour or any similar hot air or smoke movement can cause the light to switch on when it is not required to do so.

Passing cars (with warm engines) or the motion of nearby trees and bushes, sudden changes in temperature and gusts of wind can also cause the light to switch on.

If the light has been placed under a roof or under trees, it may also come on during daylight hours.

If the light does not work, the power supply could be defective or there may have been a failure in the electrical circuit.

If the temperature difference between the object to be detected and surrounding area is too small (in the summer for example), the light will react later. The range of detection may then be 10 meters instead of 10 meters for example.

PARTS REPLACEMENT

Immediately replace a cracked or broken protective glass. Always use original parts for this which can be purchased on request from your Clarke spares department.

There are no other user serviceable parts inside the light. DO NOT disassemble the unit.

DECLARATION OF CONFORMITY



Clarke[®]
INTERNATIONAL

Hemnall Street, Epping, Essex CM16 4LG

DECLARATION OF CONFORMITY

This is an important document and should be retained.

We hereby declare that this product(s) complies with the following directive(s):

2004/108/EC *Electromagnetic Compatibility Directive.*

2006/95/EC *Low Voltage Equipment Directive.*

2011/65/EU *Restriction of Hazardous substances.*

The following standards have been applied to the product(s):

EN 55015:2006 +A1:2007 +A2:2009, EN 61547:2009, EN 61000-3-2:2006 +A1:2009 +A2:2009,

EN 61000-3-3:2008, EN 60598-2-5:1998, EN 60598-1:2008 +A11:2009, EN 62471:2008,

EN 62493:2010.

The technical documentation required to demonstrate that the product(s) meet(s) the requirement(s) of the aforementioned directive(s) has been compiled and is available for inspection by the relevant enforcement authorities.

The CE mark was first applied in: 2013

Product Description: LED Security light with PIR motion sensor
Model number(s): CL6PIR
Serial / batch Number: N/A
Date of Issue: 20/01/2015

Signed:

J.A. Clarke
Director

A SELECTION FROM THE VAST RANGE OF

Clarke®

QUALITY PRODUCTS

AIR COMPRESSORS

From DIY to industrial, Plus air tools, spray guns and accessories.

GENERATORS

Prime duty or emergency standby for business, home and leisure.

POWER WASHERS

Hot and cold, electric and engine driven - we have what you need

WELDERS

Mig, Arc, Tig and Spot. From DIY to auto/industrial.

METALWORKING

Drills, grinders and saws for DIY and professional use.

WOODWORKING

Saws, sanders, lathes, mortisers and dust extraction.

HYDRAULICS

Cranes, body repair kits, transmission jacks for all types of workshop use.

WATER PUMPS

Submersible, electric and engine driven for DIY, agriculture and industry.

POWER TOOLS

Angle grinders, cordless drill sets, saws and sanders.

STARTERS/CHARGERS

All sizes for car and commercial use.



PARTS & SERVICE: 0208 988 7400

E-mail: Parts@clarkeinternational.com or Service@clarkeinternational.com

SALES: UK 01992 565333 or Export 00 44 (0)1992 565335

Clarke® INTERNATIONAL Hemnall Street, Epping, Essex CM16 4LG
www.clarkeinternational.com