

Blamke®



GAS HEATER

Model No: GRH125

OPERATING & MAINTENANCE
INSTRUCTIONS



1106



SPECIFICATIONS

Rating BTU Output	125,000 Btu/hr
Gas Consumption - per hour	2.6kg
Gas Hose Length	3610mm
Regulator Type	37mbar
Dimensions	475x400x1090mm
Weight unpacked	18.19kg
Part No.	6920017

PARTS & SERVICE CONTACTS

For Spare Parts and Service, please contact your nearest dealer,
or CLARKE International, on one of the following numbers.

PARTS & SERVICE TEL: 020 8988 7400

PARTS & SERVICE FAX: 020 8558 3622

or e-mail as follows:

PARTS: Parts@clarkeinternational.com

SERVICE: Service@clarkeinternational.com

Thank you for purchasing this CLARKE Gas Heater. designed for commercial use only, i.e. **NOT** for domestic use.

This portable gas heater is designed to BS 4096 for industrial applications, to give safe, efficient and reliable operation, and is for use with **Propane Gas only**. Propane gas bottles are not supplied with the unit, but are readily available from Builders Merchants or gas suppliers.

As with all mechanical equipments, optimum performance will only be achieved if the correct application and servicing procedures are followed.

Please read this leaflet thoroughly and follow the instructions carefully before attempting to use the heater. In doing so you will ensure the safety of yourself and that of others around you, and you can look forward to it giving you long and reliable service. Keep this booklet safe for future reference, as any person who has not read this booklet should not be allowed to operate the heater.

GUARANTEE

This CLARKE product is guaranteed against faulty manufacture for a period of 12 months from the date of purchase. Please keep your receipt as proof of purchase.

This guarantee is invalid if the product is found to have been abused or tampered with in any way, or not used for the purpose for which it was intended.

Faulty goods should be returned to their place of purchase, no product can be returned to us without prior permission.

This guarantee does not effect your statutory rights.

CONTENTS

PAGE

Safety Precautions	4
Unpacking/Features	5
Ventilation	6
Installation	6
Operation	7
Cleaning & Maintenance	9
Trouble Shooting	10
Parts List And Diagram	11

PRECAUTIONS

WARNING!

**Lack of ventilation can cause Carbon Monoxide poisoning.
Carbon Monoxide poisoning can kill.**

Signs of Carbon Monoxide poisoning are, headaches, dizziness and/or nausea. Should anyone show these signs, they must GET FRESH AIR IMMEDIATELY. Turn off the heater and have it serviced before using again.

Pregnant women, persons with a heart or lung condition, anaemia or under the influence of alcohol, or those at high altitudes, are more likely to be effected by Carbon Monoxide than others.

Read, and make sure you fully understand the following precautions and the hazards associated with this type of equipment.

- **This heater is not designed for use on finished floors.**
- **NEVER move the heater when it is lit.**
- **Use ONLY Propane gas**
- **Ensure the Propane gas bottle and gas hose are positioned BEHIND the unit, well away from the heat... minimum distance of 6 feet (2M)**
- **Ensure all gas hose and regulator connections are GAS TIGHT, and the hose is not kinked.**
- **NEVER use the heater where Gasoline, Paint thinner or other highly flammable vapour or high dust content is present.**
- **Use ONLY in well ventilated areas. Provide a ventilation opening of at least 3 square feet to fresh, outside air.**
- **The minimum clearance from any combustible materials is 8 feet (245cm) from the front and 4 feet (120cm) from the top and sides.**
- **ALWAYS locate the heater on a stable, firm level surface**
- **Keep children and animals well away from heater at all times.**
- **Use heater in accordance with all fire regulations.**
- **NEVER use heater in living or sleeping areas.**
- **NEVER leave a heater, when lit, unsupervised - an individual should always be made responsible for monitoring it.**
- **NEVER move, handle, replenish gas supply or service the heater when it is hot, or operating .**
- **Use ONLY the regulator supplied with the heater.**
- **If the heater works for long periods, be aware that it is possible for ice to form on the cylinder, due to excessive evaporation. NEVER direct hot air towards the cylinder in order to de-ice. The cylinder temperature should NEVER exceed 100°F (38°C)**
- **ALWAYS store gas cylinders according to 'Highly Flammable Liquids and Liquefied Petroleum Gases Regulations 1972'**

UNPACKING

On unpacking, check the heater for possible shipping damage. Should any damage be apparent, please notify your Clarke dealer immediately.

Your heater is fully assembled, It is only necessary to connect the gas supply.

FEATURES

Understanding the basic operation of the heater, will reinforce the need to maintain the unit in top condition at all times, whilst **always** observing the safety precautions.

The heater comprises three basic systems:

1. The gas system.
2. The ignition system.
3. The safety control system.

1. Gas System

The gas supply to the machine is by means of a high pressure hose, connected to a LPG cylinder, via a pressure regulator.

When the gas valve is opened, gas will flow to the Control Valve and finally the burner.

This heaters is designed for use with PROPANE gas ONLY. Gas bottles are not supplied, but are readily available from builders merchants or gas suppliers etc.

This heater is designed to operate with a minimum 20 pound (9 kg) propane tank. You may need two or more tanks or one larger tank in colder weather. Use a 100 pound (45 kg) tank for longer operation or in very cold weather. Less gas is vaporized at lower temperatures. Your local propane gas dealer will help you select the proper supply system. The minimum surrounding air temperature rating for each heater is -20° F (-29°C).

2. Ignition System

A Piezoelectric Igniter is positioned at the Pilot Light. When the Igniter button is depressed (C, Fig.2), a high intensity spark is generated, which ignites the gas. Heat from the flame is sensed by a Thermocouple, which is connected to the Flame Failure Valve. As the Thermocouple heats up, a low voltage is fed to the Safety Cut-Off Valve, causing the valve to open, so that after a short period, the Control Valve (see `Lighting the Heater on p8) may be released, and the pilot flame is established.

3. The Safety Control System.

Should the flame extinguish for any reason, the Thermocouple will quickly cool, causing the Flame Failure Valve to close, shutting off the gas supply.

VENTILATION



Provide at least a 10ff² opening of fresh, outside air whilst running this heater. If proper fresh, outside air ventilation is not provided, carbon monoxide poisoning can occur.

INSTALLATION

Read these instructions carefully. Do not allow anyone who has not read these instructions to light, adjust or operate this heater.

Do not attempt to operate the heater with any gas other than propane

This heater, including hose and regulator assembly, must be inspected before each use and at least annually by a qualified service person. If the hose shows evidence of excessive abrasion or wear or if the hose is cut, it must be replaced prior to the heater being put into operation. The replacement hose assembly shall be that specified by Clarke International.

Positioning the Heater

The heater and propane gas cylinder must be located on a hard, flat, level surface to minimize the risk of accidental tipping. The propane gas cylinder should be adequately restrained to prevent accidental tipping. **DO NOT operate this heater with the supply cylinder in any other than the upright position.**

This appliance must be located only in places where the potential for physical damage to the appliance, or to individuals (burns), is reduced to a minimum.

This appliance produces radiant heat. Therefore, it must be located at least 6 feet away from any propane gas cylinder and must not be directed toward any gas container within 20 feet.

The heater must be located such that it will not be exposed directly to water spray, rain and/or dripping water.

Use of this heater in a draft/windy area decreases its efficiency. If possible, operate the unit in a draft free area.

OPERATING INSTRUCTIONS

WARNING:

If you do not follow these instructions exactly, a fire or explosion may result causing property damage, personal injury or loss of life.

The heater must be positioned at least **6 feet** away from the propane cylinder. If more than one heater is used, they and the supply cylinders must be separated by at least **20 feet**.

CAUTION:

**This appliance is hot during normal operation, avoid physical contact.
Do not place clothing or other combustible materials on this appliance.**

DO NOT operate this heater if any part has been under water. Call a qualified service technician to inspect the appliance and to replace any part of the control system or gas control valve which has been under water.

Gas Connection

The connection to a propane cylinder must be made in a well ventilated area using the regulator and hose assembly supplied with the appliance. DO NOT attempt to adjust this regulator. It has been preset at the factory to provide safe and proper operation of the appliance.

Attach the regulator to the gas cylinder ensuring the cylinder orifice is perfectly clean - blow out with compressed air if necessary, or open the gas valve quickly and briefly to blast away any dust or dirt, Turn the nut in an anticlockwise direction - i.e. LEFT HAND THREAD, until tight. DO NOT use a thread compound on threads. To check for leaks, use soapy water, or liquid soap ONLY.

IMPORTANT: The gas hose and cylinder must ALWAYS be positioned at a distance of at least 6 feet (2M) from the heater.

In order to reduce the risk of icing up when operating at long periods at maximum capacity, you should use a larger capacity gas bottle, or two/three bottles in parallel, as shown in Fig. 1.

The Tee piece and 'pigtailed' are readily available from Builders Merchants or gas suppliers.

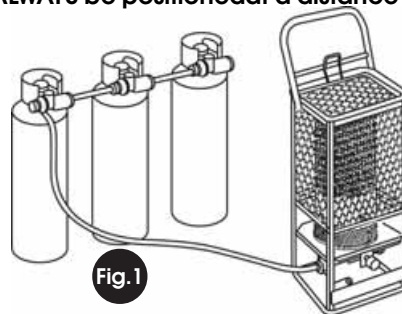

WARNING

Propane Gas cylinders must be used and stored in accordance with the 'Highly Flammable Liquids and Liquefied Petroleum Gases Regulations 1972'

Lighting the Heater

WARNING!

Before starting the heater, you **MUST** ensure that the minimum ventilation requirements are observed to avoid the risk of carbon monoxide poisoning.

1. Ensuring there is sufficient gas, and that it is correctly connected and leak free - turn the Control Knob (Fig. 3) fully clockwise so that OFF is uppermost. To do this you must first push the knob IN .
2. Turn on the gas supply and check all fittings and connections for gas leaks, by smell, and if necessary, using a mild soap and water solution. **NEVER** use a match to check for gas leaks.
3. When satisfied, turn the Control Knob anticlockwise to the 'Pilot' position.
4. Press and hold the Control Valve IN, whilst repeatedly pressing the Piezo Electric starter (C, Fig.2) until the pilot light ignites. (The pilot light may be viewed through the window shown at 'A' Fig.2).

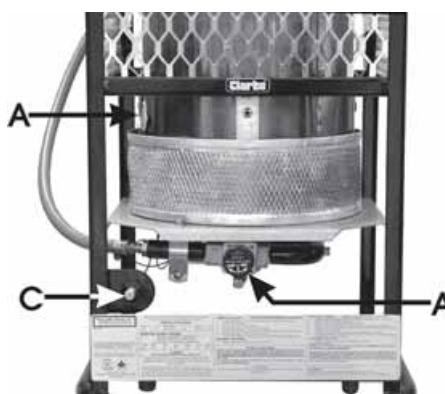

Fig.2

NOTE: If a new gas cylinder has been connected, it may take some time for the gas line to be purged of air. Press the Piezo electric button every 10-15 seconds until the pilot ignites.

Continue to hold IN the control knob for approx. 1 minute, or until the pilot light remains lit when it is released.

5. With the pilot light lit, turn the control valve anticlockwise so that ON is uppermost. The burner will now ignite.



Fig.3

NOTE: a. The heater, has a fixed, regulated gas flow

- b. In cases where long runs of gas supply lines have been installed ahead of the appliance, it may be necessary to bleed trapped air out of supply lines before lighting pilot. New installations generally require bleed of supply lines. It could take several minutes before the pilot can be lit, depending upon the length of the supply line.*

Shutting OFF the Heater

A. For Short Periods.

Simply turn the control knob clockwise to the 'Pilot' position.

B. For Prolonged periods.

1. Turn the Control Knob clockwise to the Pilot position, then push the knob IN and turn a further quarter turn to the OFF position.
2. Close propane gas supply cylinder valve

CLEANING AND MAINTENANCE

WARNING: Never attempt to service heater while it is
(a) connected to propane supply,
(b) operating
(c) hot. (Severe burns can occur.)

1. Turn heater off and let cool at least 20 minute, before cleaning.
2. Keep heater clean. Clean it annually or as needed to remove dust and debris. If heater is dirty or dusty, clean it with a damp cloth. Use household cleaners on difficult spots.
3. Inspect heater before each use. Check connections for leaks. Apply mixture of liquid soap and water to connections. Bubbles forming show a leak. Correct all leaks at once.
4. Clean inside heater using compressed air where possible. Blow air back and forth along the entire burner face until all dust has been dislodged from surface of the screen. Blow air through venturi from the control end (orifice) of heater.
5. Inspect hose/regulator assembly before each use. If hose is badly worn or cut, have it replaced.
6. Have heater inspected yearly by a qualified service agency.

Adjusting the Pilot Light

Pull off the control knob, then unscrew the Hex Head screw immediately beneath the control block, to reveal the adjuster screw, arrowed in Fig.4.

Adjust the pilot light so that it burns steadily with a blue flame. It should not be yellow. Replace the Hex head screw



Fig.4

TROUBLE SHOOTING

FAULT	CAUSE	REMEDY
Burner fails to light	<ol style="list-style-type: none"> 1. Gas supply valve closed 2. Excess-flow check valve 3. Blockage in burner orifice 4. Piezo ignition not sparking 	<ol style="list-style-type: none"> 1. Open gas supply valve slowly 2. Close propane supply valve on closed propane tank and reopen slowly 3. Replace burner orifice 4. Assure igniter electrode gap is 5.0 mm (0.195 in). Check wire lead for damage Replace piezo igniter and/or igniter electrode as necessary. Do not bend electrode, this may cause breakage
No gas flow to the burner	<ol style="list-style-type: none"> 1. Cylinder gas tap closed. 2. Cylinder is empty. 3. The orifice is obstructed. 4. Gas leaks from the supply hose or from the tap. 5 Low gas pressure 6 Thermocouple loose or needs to be replaced 7. Automatic control valve needs to be replaced 8. Loose wires on tip over switch 9. Loose or broken wire 10. Loose or dislocated 11. Defective thermocouple 12. Defective control 	<ol style="list-style-type: none"> 1. Open the gas tap. 2. Replace cylinder. 3. Remove the orifice and clean it. 4. Use soapy water to find the leak, and repair. 5. Check for proper gas supply 6. Tighten connection or replace thermocouple 7 Replace automatic control valve 8. Tighten wires on tip over switch 9. Tighten or repair wire 10. Tighten thermocouple. Make sure thermocouple is located correctly between reverberator and grid thermocouple wire 11. Replace thermocouple 12. Replace control
The Heater stops during operation.	<ol style="list-style-type: none"> 1. Excessive gas supply. 2. Insufficient gas supply due to ice formation on the cylinder. 3. The tip-over switch has tripped. 	<ol style="list-style-type: none"> 1. Check the pressure regulator, and replace if necessary. 2. Check, and use a larger cylinder, or two or more in parallel. 3. Investigate cause. If heater has fallen over, right it and investigate cause. Take steps to prevent recurrence

PARTS LIST AND DIAGRAM

Use **ONLY** replacement parts supplied by CLARKE International.
The use of other parts, unless specified, could lead to fatal consequences and invalidate your warranty.

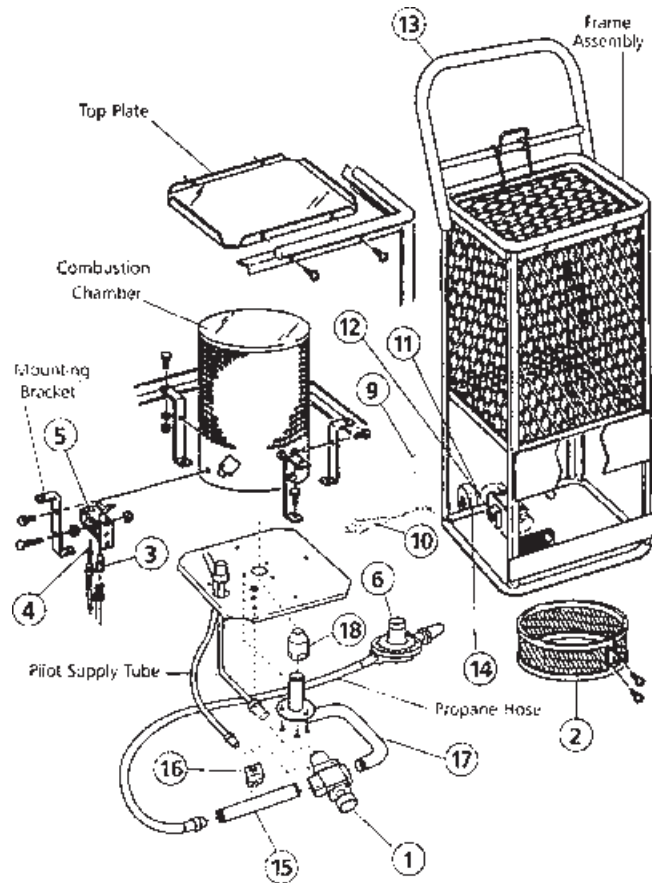

No.	Description	Part No	No.	Description	Part No.
1	Manual Control Valve	GRH12500332	11	Axle	GRH125CR820
2	Filter/ Diffuser	GRH12504466	12	Axle Brackets	GRH125CR815
3	Pilot Orifice	GRH12505363	13	Handle	GRH125CR725
4	Thermocouple	GRH12509352	14	Wheel	GRH125CR810
5	Pilot Burner	GRH12511357	15	Valve Supply Tube	GRH125M9005
6	Regulator	GRH12511663	16	Clamp	GRH125M9010
9	Ignitor	GRH125CR805	17	Burner Manifold	GRH125M9015
10	Piezo Starter	GRH125CR835	18	Burner	GRH125M902 0