

# Glantke®

## air



## GREASE GUN

MODEL NO: CAT33B

PART NO: 3110433

## OPERATING & MAINTENANCE INSTRUCTIONS

GC04/15

---

## INTRODUCTION

---

Thank you for purchasing this CLARKE Grease Gun.

Before attempting to use this product, please read this manual thoroughly and follow the instructions carefully. In doing so you will ensure the safety of yourself and that of others around you, and you can look forward to your purchase giving you long and satisfactory service.

---

## GUARANTEE

---

This product is guaranteed against faulty manufacture for a period of 12 months from the date of purchase. Please keep your receipt which will be required as proof of purchase.

This guarantee is invalid if the product is found to have been abused or tampered with in any way, or not used for the purpose for which it was intended.

Faulty goods should be returned to their place of purchase, no product can be returned to us without prior permission. This guarantee does not effect your statutory rights.

---

## SPECIFICATION

---

<b>Model Numbers</b>	<b>CAT33B</b>
Part Numbers	3110433
Maximum Operating Pressure	90 psi (6.2 bar)
Air Consumption	1 cfm
Capacity	400 gram cartridge
Air Inlet Size	1/4" BSP thread
Vibration Levels	<2.5m/s <sup>2</sup>
Weight	1.5 kg

---

# GENERAL SAFETY RULES

---



CAUTION: FAILURE TO FOLLOW THESE PRECAUTIONS COULD RESULT IN PERSONAL INJURY, AND/OR DAMAGE TO PROPERTY.

---

## WORK ENVIRONMENT

1. Keep the work area clean and tidy.
2. Dress appropriately - Do not wear loose clothing or jewellery. Tie long hair out of the way.
3. Keep children and visitors away - Do not let children handle the tool.
4. Keep the air supply hose away from heat, oil and sharp edges.
5. Do not fit the tool to any stand or clamping device that may damage it.

## USE

1. Stay alert and use common sense - do not operate this tool when you are tired or under the influence of alcohol, drugs or medication.
2. Always wear eye protectors when using air tools. Eye protectors must provide protection from flying particles from the front and the side.
3. Do not overreach - Keep proper footing and balance at all times.
4. Never use oxygen, CO<sub>2</sub>, combustible gasses, or any bottled gas, as a source of power for the grease gun. This product should only be used with a suitably rated compressed air supply.
5. Do not connect the airline with your finger on the trigger of the gun.
6. Do not exceed the maximum pressure for the gun of 90 psi / 6.2 bar.
7. Check hoses for leaks or excessive wear before use, and ensure that all connections are secure.
8. Do not use the tool for any other purpose than described in this manual.
9. Do not carry out any alterations or modifications to the tool.
10. Always disconnect from the air supply when:
  - Performing any maintenance.
  - The tool is not in use.
  - The tool will be left unattended.
  - Moving to another work area.

- Passing the tool to another person.
- Never use the tool if it is defective or operating abnormally.

11. This tool should be serviced regularly by qualified service personnel.

12. Avoid damaging the tool for example by applying excessive force.

13. Always maintain the tool. Keep it clean for the safest performance.

14. Do not force or misuse the tool. It will do a better and safer job at the rate for which it was designed.

## TRANSPORTATION

1. Never carry an air tool by the air supply hose.
2. Never carry an air tool with your finger on the trigger.

## OVERVIEW

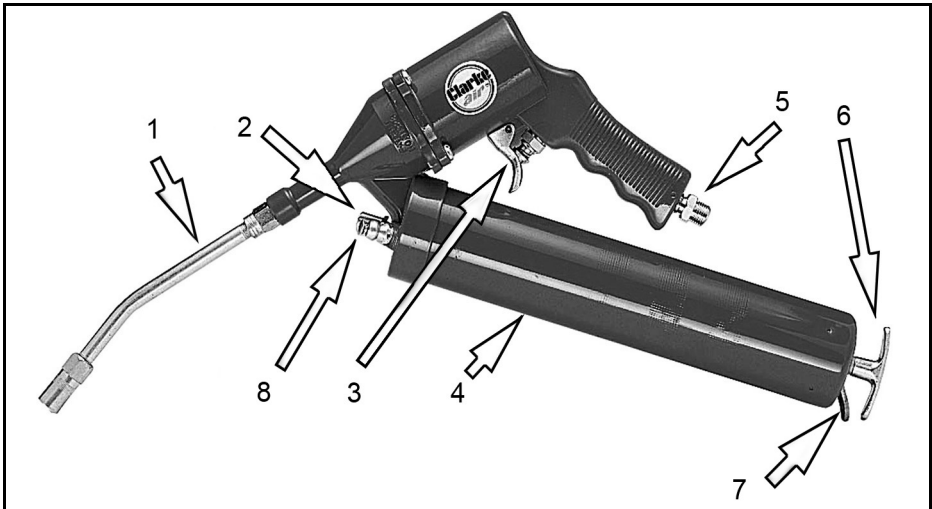

NO	DESCRIPTION	NO	DESCRIPTION
1	Nozzle	5	Air Inlet
2	Air Vent Valve	6	Plunger Handle
3	Trigger	7	Plunger Release Tab
4	Grease Container	8	Grease Inlet Valve

# COMPRESSED AIR REQUIREMENTS



**WARNING: COMPRESSED AIR CAN BE DANGEROUS. ENSURE THAT YOU ARE FAMILIAR WITH ALL PRECAUTIONS RELATING TO THE USE OF COMPRESSORS AND A COMPRESSED AIR SUPPLY.**

- Use only clean, dry, regulated compressed air as a power source.
- Air compressors used with the tool must comply with the appropriate European Community Safety Directives.
- A build-up of moisture or oil in the air compressor will accelerate wear and corrosion in the tool. ensure any moisture is drained from the compressor daily and the inlet filter is kept clean.
- If an unusually long air hose is required, (over 8 metres), the line pressure or the hose inside diameter may need to be increased.
- The air hose must be rated at least 150% of the maximum operating pressure of the tool.

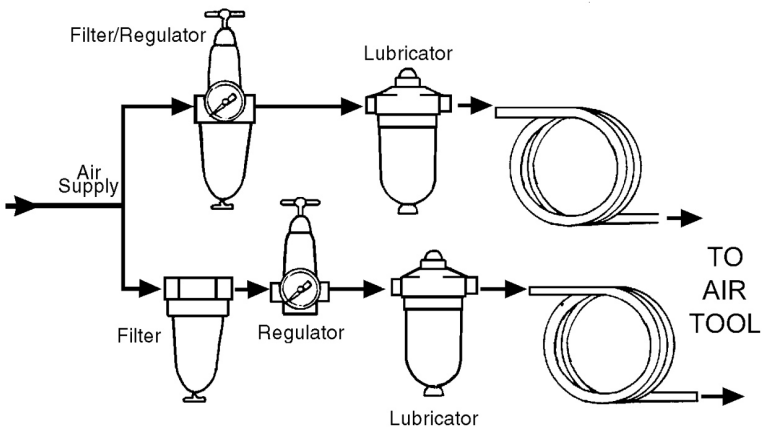

- A typical air line layout is shown above. If an automatic in-line filter/regulator is used, it will keep the tool in good condition, but should be regularly checked & topped up with oil. Clarke air-line oil should be used, and the lubricator adjusted to approx 2 drops per minute.
- Never exceed the maximum operating pressure for the tool. It is recommended that air pressure to this tool does not exceed 90 psi at the tool when running. Higher pressures and unclean air will shorten the life of the tool due to faster wear and is a possible safety hazard.

---

## BEFORE USE

---

**NOTE:** Ensure the compressor is turned off.

1. If required, connect an in-line mini oiler to the tool.
  - A mini oiler helps to prolong the life of the air tool.
2. If a mini-oiler is not being used, run a few drops of oil through the tool before use. It can be entered through the inlet connector or via the hose at the nearest connection to the air supply.
3. Connect a suitable hose as shown.
4. Connect the other end of the hose to the compressor.
5. Turn on the air supply and check for air leaks. Rectify any found before proceeding. PTFE tape may be helpful for sealing threaded connections.
6. Your air tool is now ready for use.

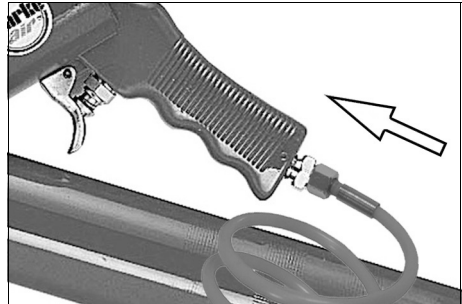

You can fit a whip hose with a quick fit coupling if required (available from your Clarke dealer).

## LOADING WITH GREASE

This air driven grease gun is designed to be loaded in one of three ways:

- Using a standard 400 gram grease cartridge.
- Loading the container with a filler pump.
- Loading the container by bulk filling.

### CARTRIDGE LOADING

1. Unscrew the container from the head of the grease gun.
2. Pull the plunger handle on the container completely out.
3. Remove any seal or end cap from the end of the grease cartridge.
4. Insert the grease cartridge all the way into the container.



5. Re-fit the container to the head of the grease gun.
6. Press the handle release tab to release the plunger handle.
7. Press the air vent valve to release any excess air trapped inside the gun.

### **LOADING USING A FILLER PUMP (IF AVAILABLE)**

1. Pull the plunger handle on the container completely out.
2. Fit the filler pump to the grease gun inlet valve.
3. Fill the container by pumping the filler pump handle.
4. Disconnect the grease gun inlet valve from the filler pump.
5. Press the handle release tab to release the plunger handle.
6. Press the air vent valve to release any excess air trapped inside the gun.

### **BULK FILL LOADING**

1. Remove the container from the head of the grease gun.
2. Pull the plunger handle on the container completely out.
3. Fill the container with bulk grease.
4. Re-fit the container to the grease gun.
5. Press the handle release tab to release the plunger handle.
6. Press the air vent valve to release any excess air trapped inside.

## **OPERATING THE GREASE GUN**

1. Connect the gun to the air hose.

**NOTE:** It is recommended that a whip hose with a swivel (not included) be used to prevent twisting, kinking and resultant wear to the air hose.

2. Squeeze the trigger completely to operate the grease gun.
  - The grease is applied in shots, not in a continuous flow.
3. Release the trigger after each shot.

## **DISCONNECTING THE AIR SUPPLY**

Do not disconnect the air supply hose until the compressor has been shut down and the compressed air released.

1. Refer to the compressor instruction manual for the procedure to shut down and release the compressed air.
2. Once the pressure has been released, disconnect the air supply hose from the air tool.

---

# MAINTENANCE

---



**WARNING: MAKE SURE THAT THE AIR TOOL IS DISCONNECTED FROM THE AIR SUPPLY BEFORE STARTING ANY CLEANING, OR MAINTENANCE PROCEDURES.**

---

## DAILY

1. Before use, drain water from the air-line and compressor.
2. This air tool should be lubricated before use. Turn the tool upside down and pour 1-2 drops of Clarke air-line oil into the air inlet. This should be carried out regardless of whether or not an in-line mini oiler is used. If an in-line mini oiler is not used, this procedure should be repeated after every two to three hours of constant use.

## CLEANING

1. Keep the body and nozzle of the tool clean.
2. Deposits in the tool may also reduce efficiency. This can be corrected by cleaning the air inlet and flushing out the tool with gum solvent oil, or failing this, the tool should be disassembled, thoroughly cleaned, dried and reassembled.
3. If the tool becomes inefficient and the air supply is of good quality, it may be necessary to replace worn or damaged parts. You may prefer to take the tool to your Clarke dealer if internal maintenance is required.

Your Clarke air tool has been designed to give long and trouble free service. If, however, having followed the instructions in this booklet carefully, you encounter problems, take the unit to your local Clarke dealer.

## PERFORMANCE

Please note that factors other than the tool may effect its operation and efficiency such as reduced compressor output, excessive drain on the airline, moisture or restrictions in the air-line, or the use of connectors of improper size or poor condition which will reduce air supply.

\*\*Clarke Air-line Oil (part no. 3050825) is available from your Clarke dealer.

## STORAGE

If the tool is to be stored, or is idle for longer than 24 hours, run a few drops of Clarke air-line oil into the air inlet, and depress the trigger in order to lubricate the internal parts.



When not in use, disconnect from air supply, clean and store in a safe, dry place.

## ACCESSORIES

Multi-purpose grease (high melting point Lithium based), 400g cartridge;- part no 3050875 is available from your Clarke dealer.

A wide range of airline accessories is available including filter/regulators, lubricators, high-pressure hoses (5 to 50 metres) etc.

Contact your Clarke dealer for further information or Clarke International Service Department on 01992 565333.

## TROUBLESHOOTING

SYMPTOM	PROBLEM	SOLUTION
Grease gun fails to work or is slow.	Air pockets in the gun	Draw back the plunger handle fully and release by pressing the handle release. Repeat several times. This will help to move the rubber ring into the cartridge tube, which essential for the grease gun to work. Push the plunger handle all the way in. Press the air vent valve several times to free the air.
	Air hose leaks.	Tighten and seal hose fittings with teflon tape.
	Low air pressure.	Adjust compressor regulator to 90 psi.
	Plunger is sticking.	Lubricate plunger.
	Cartridge is empty	Refill the container tube.
	Grease gun is too cold.	The gun needs to be at room temperature(65-80°F)
Gun will not shut off.	O-rings damaged or ill-fitting in seat.	Return to Clarke dealer for repair.

# PARTS LIST & DIAGRAM

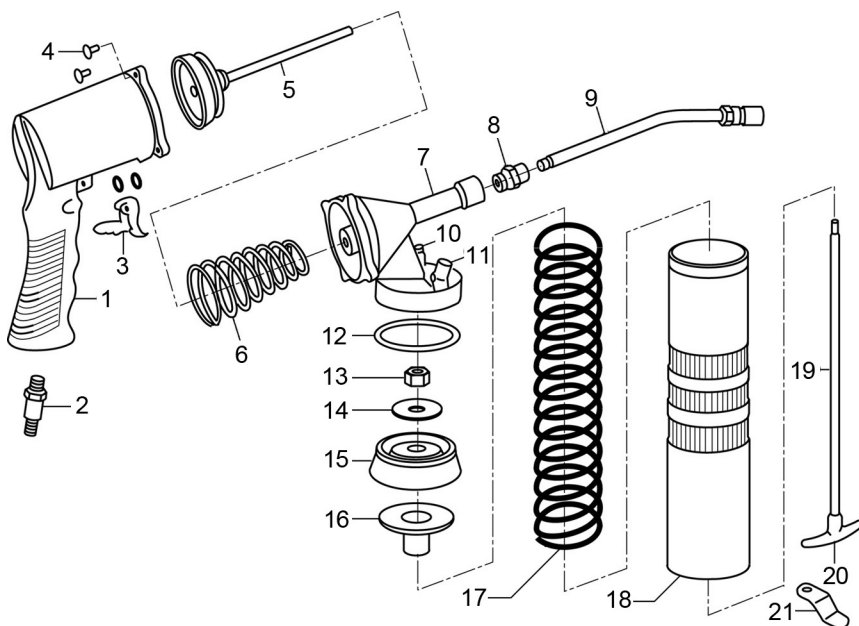

No	Description
1	Gun Body
2	Air Connector
3	Trigger
4	Screw
5	Air Plunger
6	Short Spring Kit
7	Body Cap
8	Adaptor
9	Extension with nozzle
10	Air Vent Valve
11	Plug

No	Description
12	Gasket
13	Nut
14	Flat Washer
15	Piston
16	Piston Support
17	Long Spring Kit
18	Grease Chamber
19	Piston Rod
20	Plunger Handle
21	Plate

# DECLARATION OF CONFORMITY

**Clarke**<sup>®</sup>  
INTERNATIONAL



## CERTIFICATE OF CONFORMITY

We declare that this product complies to the following standards/directives:

- 89/329/EEC
- EN 292-2

Product Description: **AIR TOOL**

Model Number: **CAT33**

Serial (Batch) No: **14L**

Signed

A handwritten signature in black ink, appearing to be 'M. J.', is written over a horizontal line.

**Clarke** INTERNATIONAL  
Epping, Essex, CM16 4LG, England

# A SELECTION FROM THE VAST RANGE OF

# Clarke®

## QUALITY PRODUCTS

### AIR COMPRESSORS

From DIY to industrial, Plus air tools, spray guns and accessories.

### GENERATORS

Prime duty or emergency standby for business, home and leisure.

### POWER WASHERS

Hot and cold, electric and engine driven - we have what you need

### WELDERS

Mig, Arc, Tig and Spot. From DIY to auto/industrial.

### METALWORKING

Drills, grinders and saws for DIY and professional use.

### WOODWORKING

Saws, sanders, lathes, mortisers and dust extraction.

### HYDRAULICS

Cranes, body repair kits, transmission jacks for all types of workshop use.

### WATER PUMPS

Submersible, electric and engine driven for DIY, agriculture and industry.

### POWER TOOLS

Angle grinders, cordless drill sets, saws and sanders.

### STARTERS/CHARGERS

All sizes for car and commercial use.



**PARTS & SERVICE: 0208 988 7400**

**E-mail: [Parts@clarkeinternational.com](mailto:Parts@clarkeinternational.com) or [Service@clarkeinternational.com](mailto:Service@clarkeinternational.com)**

**SALES: UK 01992 565333 or Export 00 44 (0)1992 565335**

**Clarke® INTERNATIONAL** Hemnall Street, Epping, Essex CM16 4LG  
[www.clarkeinternational.com](http://www.clarkeinternational.com)