

CLARKET[®]

air



3/4" (20mm)

HEAVY DUTY IMPACT WRENCH

Model No: CAT48

Model No: 3110680

OPERATING & MAINTENANCE INSTRUCTIONS

CE

GC04/14

INTRODUCTION

Thank you for purchasing this CLARKE Impact Wrench.

Before attempting to operate the machine, it is essential that you read this manual thoroughly and carefully follow all instructions given. In doing so you will ensure the safety of yourself and that of others around you, and you can also look forward to the product giving you long and satisfactory service.

GUARANTEE

This CLARKE product is guaranteed against faulty manufacture for a period of 12 months from the date of purchase. Please keep your receipt as proof of purchase. This guarantee is invalid if the product is found to have been abused or tampered with in any way, or not used for the purpose for which it was intended.

Faulty goods should be returned to their place of purchase, no product can be returned to us without prior permission. This guarantee does not effect your statutory rights.

TECHNICAL SPECIFICATION

Feature	Specification
Net Weight	4.8 kg
Dimensions (l x w x h) mm	243 x 100 x 225
Drive Size	3/4" Sq
Airline Connection size	1/4" BSP
Min Air Hose Size	9.5mm dia (5/16")
Maximum Air Pressure requirement	90psi (6.2bar)
Maximum free speed	4800 rpm
Max tightening torque	550 ft/lb
Nominal Air Consumption	7.2 cfm
Sound pressure level (Lp)	95 dB(A)

Please note that the details and specifications contained herein, are correct at the time of going to print. However, CLARKE International reserve the right to change specifications at any time without prior notice.

SAFETY PRECAUTIONS

WORK ENVIRONMENT

1. Keep the work area clean and tidy.
2. Dress appropriately - do not wear loose clothing or jewellery. Tie long hair out of the way.
3. Keep children and visitors away - do not let children handle the wrench. Make sure that any other persons in the work area are suitably dressed and are wearing eye and ear protection.
4. Keep the work area well lit.
5. Although the impact wrench may be used outdoors, do not leave it exposed to the elements. Avoid direct sunlight, direct heat, rain/moisture etc.
6. Keep the air supply hose away from sources of heat, oil and sharp edges.
7. Do not fit the wrench to a stand or clamping device that may damage it.

GENERAL USE

1. ALWAYS stay alert and use common sense - do not use this product when you are tired or under the influence of alcohol or medication.
2. Always wear eye protection when using the impact wrench to provide protection from flying particles from the front and the side.
3. Always wear ear protectors when using the impact wrench.
4. Do not over-reach. Keep proper footing and balance at all times.
5. Never use any type of bottled gas as a source of power for the wrench.
6. Do not connect the air supply hose with your finger on the trigger
7. Do not exceed the maximum pressure for the wrench: (90 psi / 6 bar).
8. Check air hoses for leaks or worn condition before use, and ensure that all connections are secure.
9. Do not use the wrench for any purpose other than that described in these instructions.
10. NEVER carry out any alterations or modifications to this product.
- 11 Always disconnect from the air supply when:
 - Performing any maintenance
 - The wrench is not in use
 - The wrench will be left unattended
 - Moving to another work area
 - Passing the wrench to another person.

12. NEVER force or misuse the tool. It will do a better and safer job at the rate for which it was designed.
12. NEVER use this product if it is defective / operating abnormally.
13. NEVER carry the wrench with your finger on the trigger.
14. Quick change couplings should not be located at the tool. They add weight and could fail due to vibration.
15. ALWAYS check the wrench for any damage or any condition that could affect its operation. Any damaged part should be properly repaired.
16. NEVER attempt any repairs yourself. If you have a problem with this product contact your local CLARKE dealer.
17. This product vibrates during use. Vibration may be harmful to your hands or arms. Stop using the machine if discomfort, a tingling feeling or pain occurs and seek medical advice before resuming use.

IMPACT WRENCH SAFETY INSTRUCTIONS

1. ALWAYS use the impact wrench in the manner and for the functions described in these instructions.
2. ALWAYS ensure the wrench is not moving and disconnected from the air supply when changing sockets etc. Use only Impact Wrench sockets....DO NOT use standard sockets.
3. ALWAYS finish tightening wheel nuts or engine parts with a torque wrench or suitable spanner to the correct torque as recommended by the vehicle manufacturer.
4. ALWAYS avoid excessive use of the impact wrench. When tightening a nut or bolt, never allow the wrench to impact more than 8 times - to avoid over tightening - 3 to 4 impacts is normally sufficient.
5. ALWAYS ensure that the socket is correctly installed before switching on.
6. ALWAYS only use sockets which are specified for impact wrench use.
7. Due to the possible presence of asbestos dust from brake linings, always wear suitable respiratory protection.
8. Never carry the impact wrench by the air supply hose.
9. ALWAYS disconnect from the air supply when changing bits or when the wrench is not required for immediate use in order to avoid accidental starting.
10. ALWAYS store this product in a dry, secure place out of reach of children or untrained users.
11. ALWAYS use both hands to control the impact wrench.
12. ALWAYS ensure the wrench has stopped before putting it down after use.

Additionally, please keep these instructions in a safe place for future reference.

AIR SUPPLY REQUIREMENTS



WARNING: COMPRESSED AIR CAN BE DANGEROUS. ENSURE THAT YOU ARE THOROUGHLY FAMILIAR WITH ALL PRECAUTIONS RELATING TO THE USE OF COMPRESSORS AND COMPRESSED AIR SUPPLY.

- Use only clean, dry, regulated compressed air as a power source.
- Air compressors used with the tool must comply with the appropriate European Community safety directives.
- A build up of moisture in the air compressor will accelerate wear and corrosion in the moving parts. Ensure any moisture is drained from the compressor daily and the inlet filter is kept clean.
- If an unusually long air hose is required, (over 8 metres), line pressure may need to be increased.
- Never exceed the maximum operating pressure for the tool.
- The air hose must be rated at least 150% of the maximum operating pressure of the tool.
- A pressure of 90psi with a flow of 6 cfm is required. Too high an air pressure will shorten the life of the tool due to excessive wear.

A typical airline layout is shown. If an automatic in-line filter/regulator/lubricator unit is used it will keep the tool in good condition, but should be regularly checked and topped up with oil.

IMPORTANT: If a filter/lubricator unit is not used, the air tool should be lubricated with 2 to 6 drops of oil, at least once a day or after 2 hours work, depending upon the working environment. The oil can be inserted through the airline connection fitting.

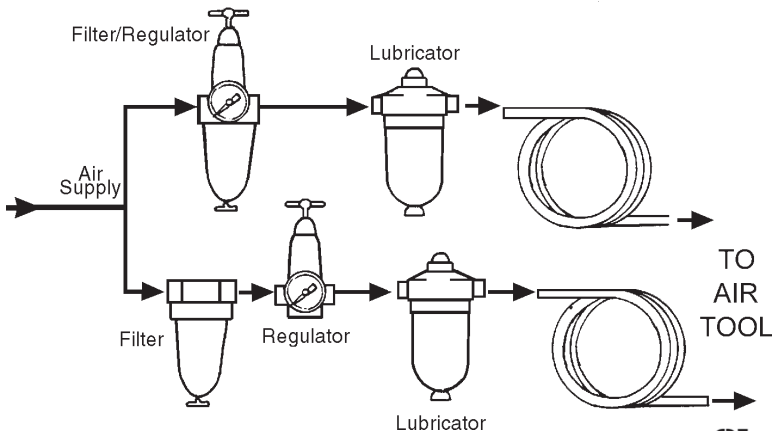

BEFORE USE

CONNECTING THE AIR SUPPLY



WARNING: COMPRESSED AIR CAN BE DANGEROUS. ENSURE THAT YOU ARE FAMILIAR WITH ALL PRECAUTIONS RELATING TO THE USE OF COMPRESSORS AND COMPRESSED AIR SUPPLIES.

Note: Ensure the compressor is turned off.

1. Remove the plastic blanking plug from the connection port of the tool as shown.
 2. Pour 2-3 drops of CLARKE airline oil into the air inlet. This should be done regardless of whether or not a lubricated air supply is to be used.
 3. Connect a suitable hose to the tool as shown.
 4. Connect the other end of the hose to the compressor. (A whip hose with a quick fit coupling is available from your CLARKE dealer).
 5. Turn on the air supply and check for air leaks. Rectify any found before proceeding. The tool is now ready for use.
-

OPERATION



CAUTION: ALWAYS BE SURE THAT THE TOOL IS SWITCHED OFF BEFORE ATTACHING OR REMOVING A SOCKET. ALWAYS TAKE CARE TO USE THE CORRECT SIZE SOCKET FOR BOLTS AND NUTS. AN INCORRECT SOCKET WILL CAUSE DAMAGE TO THE BOLT OR NUT.

1. Select an appropriate impact socket, which must be in good condition, and fits the anvil and nut closely. Use only square drive impact wrench sockets as listed on page 10. (**NEVER** use standard hand sockets).
2. Select Forward or Reverse drive by moving the lever, on the base of the wrench, to the 'F' or 'R' position. Always check the direction of rotation before operation. Select the appropriate lever when the spindle is moving.
3. Squeeze the trigger to start the wrench. Release the trigger to stop.
4. Turn the airline regulator to its lowest setting, then apply the wrench to a nut or bolt of known tightness (or torque setting), size, thread pitch, and thread condition as those on the job.
5. Start the wrench, in the **FORWARD** position, and gradually turn the air regulator until the nut or bolt moves very slightly **in the direction in which it**

was set. The tool is now set to duplicate that tightness. For future use, note that specific setting.

6. When critical torque values are not required, turn nut or bolt until it fits snugly, and then turn a further one quarter to one half a turn - slightly more if gaskets are used between surfaces.
7. For additional power during disassembly work, turn the air line regulator to its highest setting.

This tool is rated at 7/8" bolt size, and is downgraded for spring 'U' bolts, tie bolts, long cap screws, double depth nuts, badly rusted conditions, and spring loaded fasteners as these conditions absorb much of the impact power.

8. Turn off the wrench as soon as the impact sound is heard.

IMPORTANT: Where the torque setting is critical, the final tightening of nuts or bolts, must be by hand using a properly calibrated torque wrench.

LOOSENING A WHEEL NUT

1. Remove any wheel trim, before selecting the appropriate socket and placing firmly on the square drive of the wrench.
2. With the FORWARD/NEUTRAL/REVERSE switch in the REVERSE running position, and holding the wrench firmly in BOTH HANDS, pull the trigger. The nut will be impacted repeatedly until it is loosened. **IMPORTANT!** Release the trigger immediately the nut begins to loosen.
3. Jack up the vehicle according to the vehicles handbook so that the wheel is clear of the ground, then proceed to fully undo the wheel nuts.
4. Soak rusted nuts in penetrating oil, and break rust seal before twisting off with the wrench.



ENSURE THAT THE CORRECT SOCKET IS BEING USED FOR THE NUTS ON YOUR PARTICULAR VEHICLE. AN INCORRECT SOCKET SIZE IS LIKELY TO DAMAGE THE HEADS OF THE BOLTS/NUTS.

TIGHTENING A NUT

1. Start the nut by hand, ensuring it is not cross threaded, then with the appropriate socket installed on the wrench, place it on the nut.
2. With the FORWARD/NEUTRAL/REVERSE switch in the clockwise (FORWARD) running position, and holding the wrench firmly in BOTH HANDS, pull the trigger.
3. Run each nut up in turn until it is 'nipped' up only - do not tighten. When all nuts are nipped up, tighten progressively by pulling the trigger fully and allowing the action to operate for 3 to 4 impacts **only** to prevent overtightening.

4. ALWAYS finish tightening with a torque wrench. The weight of the vehicle will need to be placed on the wheel to prevent it from rotating while the nuts are tightened. Ensure the final torque applied to the nuts meets the vehicle manufacturer's recommendations.

DISCONNECTING THE AIR SUPPLY

1. Do not disconnect the air supply hose until the compressor has been shut down and the compressed air pressure released.
2. Once the pressure has been released, disconnect the air supply hose from the tool.

MAINTENANCE

DAILY

1. Before use, drain water from air reservoir, air line and compressor as appropriate.
2. If no line lubricator is used, ensure that oil is applied to the tool on a daily basis through the air inlet connection.
3. For lubricating the air motor, an air line lubricator should be used, containing Clarke Air Line Oil, adjusted to 2 drops per minute. If this is not possible, run a few drops of oil through the tool. It may be entered into the tool air inlet, (ensuring the strainer is clear), or into the hose at the nearest connection to the air supply. Then operate the tool.

Clarke Air Line Oil is available from your CLARKE dealer, part no. 3050825.

CLEANING

- Keep the body of the tool clean and free from debris.
2. Grit or gum deposits in the tool may also reduce efficiency. This condition can be corrected by cleaning the air strainer and flushing out the tool with gum solvent oil, or failing this, the tool should be disassembled, thoroughly cleaned, dried and reassembled.
 - After extensive use, remove the inlet screen filter and flush out the mechanism with gum solvent oil or an equal mixture of SAE No10 oil and paraffin. Allow to dry before use.
 1. Clean the air inlet filter screen (within parts list item 12). DIAGRAM???
 3. If the tool runs erratically or becomes inefficient, and the air supply is of good quality, it may be necessary to dismantle the air motor and hammer mechanism and replace worn or damaged parts. You may prefer to take the tool to your CLARKE dealer if internal maintenance is required.

Your Clarke Impact Wrench has been designed to give long and trouble free service. If, however, having followed the instructions in this booklet carefully, you encounter problems, take the unit to your local Clarke dealer.

SERVICE AND REPAIRS

1. Keep the tool clean at all times, and ensure that the bolts securing the case remain tight.
- All bearings etc, in this machine are lubricated with sufficient high grade lubricant for the machines lifetime under normal operating conditions, therefore no further lubrication is required.
- Be aware that outside factors may effect the wrench's operation and efficiency, These may include reduced compressor output, excessive drain on the airline, moisture in suspension or restrictions in the line, or the use of connectors of improper size or poor condition which will reduce air supply.
- Any major servicing and repairs should be carried out by your local CLARKE dealer or a qualified service technician.

STORAGE

1. Store the tool safely in its box in a dry, secure environment.
2. If the tool is not to be used for longer than 24 hours, run a few drops of CLARKE airline oil into the air inlet and run the tool for a few seconds to ensure that the oil has been well distributed throughout the tool.
3. When storing, ensure the blanking plug is replaced on the airline connector once the airline has been disconnected.

**Clarke Airline Oil is available from your CLARKE dealer: part no. 3050825

ACCESSORIES

A wide range of airline accessories is available from your nearest CLARKE dealer, for further information, contact your nearest dealer, or telephone CLARKE International Sales department on 01992 565300.

Suitable air line accessories include Air Filter/Regulators, Lubricators, Hoses, Snap Couplings, clips, gauges, valves.

Suitable Impact Wrench compatible socket sets include the following:

1800320 CIS19/9M 3/4" Impact Sockets

TROUBLESHOOTING

SYMPTOM	PROBLEM	SOLUTION
Tool runs at normal speed but slows down under load.	<ol style="list-style-type: none"> 1. Motor parts worn. 2. Worn or sticking mechanism due to lack of lubricant. 	<ol style="list-style-type: none"> 1. Return to dealer for overhaul 2. Drip air tool lubricating oil into air inlet and soak moving parts.
Tool runs slowly. Air flows lightly from exhaust.	<ol style="list-style-type: none"> 1. Motor parts jammed with gum &/or dirt particles. 2. Regulator in closed position. 3. General airflow blocked by dirt. 	<ol style="list-style-type: none"> 1. Examine inlet air filter for cleanliness. 2. Adjust regulator to open position. 3. Operate tool in short bursts of forward/reverse rotation.
Tool will not run. Air flows freely from exhaust.	<ol style="list-style-type: none"> 1. Motor vanes stuck due to buildup of foreign material. 	<ol style="list-style-type: none"> 1. Disconnect air supply & rotate tool assembly manually. 2. Try operating tool in short bursts of forward/reverse rotation. 3. Tap motor housing gently with rubber mallet. 4. Drip a few drops of air tool lubricating oil into the air inlet to soak moving parts.
Tool will not shut off.	<ol style="list-style-type: none"> 1. Throttle O-rings damaged or not seated correctly. 	<ol style="list-style-type: none"> 1. Replace O-ring or return to Clarke dealer for repair.

ENVIRONMENTAL PROTECTION



Do not dispose of this product or any unwanted materials with general household waste. All tools, accessories and packaging should be sorted, taken to a recycling centre and disposed of in a manner which is compatible with the environment.

PARTS LIST

No	Description	Part No	Qty
1	Protective Rubber	28-0030	1
2	Seal	00-4205	1
3	Housing	28-0001	1
4	Screw	00-0614	1
5	Anvil Bush	28-0014	1
6	Anvil Collar	28-0016	1
7	O-Ring	00-4118	1
8	Spacer	28-0017	1
9	Anvil	28-0015	1
10	Hammer Pin	28-0019	1
11	Hammer Cage	28-0018	1
12	Hammer	28-0020	1
13	Cam	28-0021	1
14	Seal	00-4206	2
15	O-ring	00-4108	1
16	Front Plate	28-0022	1
17	Rotor Blade	28-0024	6
18	Rotor	28-0023	1
19	Cylinder	28-0025	1
20	Washer	28-0034	1
21	Ball Bearing	00-2312	1
22	Rear Plate	28-0026	1
23	Rear Cover	28-0028	1
24	Washer	00-1803	4

No	Description	Part No	Qty
25	Screw	00-0119	4
26	Screw	00-0110	3
27	Rear Rubber	28-0031	1
28	Washer	00-1802	3
29	O-Ring	00-4111	3
30	Valve Sleeve	28-0002	1
31	Reverse Valve	28-0003	1
32	Rear Gasket	28-0027	1
33	O-ring	00-4106	1
34	Air Regulator	28-0008	2
35	Screw	00-0802	2
36	Exhaust Deflector	28-0012	1
37	Pin	28-0009	1
38	Spring	28-1031	1
39	Screw	00-0610	1
40	Trigger	28-0004	1
41	Pin	00-3301	1
42	Pin	00-3305	1
43	Valve Stem	28-0005	1
44	Spring	28-0011	1
45	Hose Adaptor	25-1010	1
46	Ball Bearing	00-2313	1
47	O-ring	00-4114	1

PARTS DIAGRAM

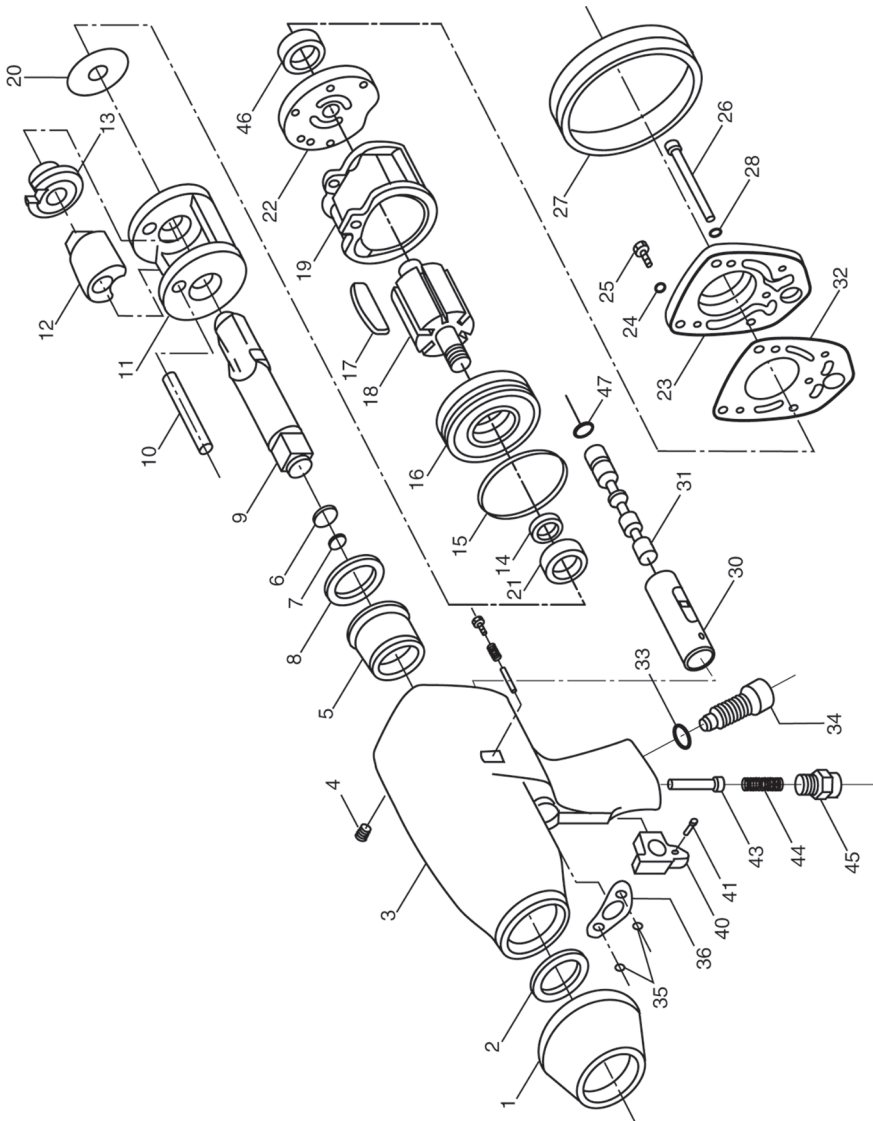

VIBRATION EMISSIONS

HAND-ARM VIBRATION

Employers are advised to refer to the HSE publication "Guide for Employers".

All hand held power tools vibrate to some extent, and this vibration is transmitted to the operator via the handle, or hand used to steady the tool. Vibration from about 2 to 1500 herz is potentially damaging and is most hazardous in the range from about 5 to 20 herz.

Operators who are regularly exposed to vibration may suffer from Hand Arm Vibration Syndrome (HAVS), which includes 'dead hand', 'dead finger', and 'white finger'. These are painful conditions and are widespread in industries where vibrating tools are used.

The health risk depends upon the vibration level and the length of time of exposure to it.....in effect, a daily vibration dose.

Tools are tested using specialised equipment, to approximate the vibration level generated under normal, acceptable operating conditions for the tool in question. For example, a grinder used at 45° on mild steel plate, or a sander on softwood in a horizontal plane etc.

These tests produce a value 'a', expressed in metres per second per second, which represents the average vibration level of all tests taken, in three axes where necessary, and a second figure 'K', which represents the uncertainty factor, i.e. a value in excess of 'a', to which the tool could vibrate under normal conditions. These values appear in the specification panel below.

MODEL No:	CAT48
DESCRIPTION:	HD IMPACT WRENCH
Declared vibration emission value in accordance with EN12096	
Measured vibration emission value - a : 16.49m/s ²	
Uncertainty value - K : 3.2m/s ²	
Values determined according to EN28622-2	

You will note that a third value is given in the specification - the highest measured reading in a single plane. This is the maximum level of vibration measured during testing in one of the axes, and this should also be taken into account when making a risk assessment.

'a' values in excess of 2.5 m/s² are considered hazardous when used for prolonged periods. A tool with a vibration value of 2.8 m/s² may be used for up to 8 hours (cumulative) per day, whereas a tool with a value of 11.2 m/s² may be used for ½ hour per day only.

The graph below shows the vibration value against the maximum time the respective tool may be used, per day.



The uncertainty factor should also be taken into account when assessing a risk. The two figures 'a' and 'K' may be added together and the resultant value used to assess the risk.

It should be noted that if a tool is used under abnormal, or unusual conditions, then the vibration level could possibly increase significantly. Users must always take this into account and make their own risk assessment, using the graph above as a reference.

Some tools with a high vibration value, such as impact wrenches, are generally used for a few seconds at a time, therefore the cumulative time may only be in the order of a few minutes per day. Nevertheless, the cumulative effect, particularly when added to that of other hand held power tools that may be used, must always be taken into account when the total daily dose rate is determined.

DECLARATION OF CONFORMITY

ClarkeTM
INTERNATIONAL



CERTIFICATE OF CONFORMITY

We declare that this product complies to the following standards/directives:

■ 89/329/EEC

■ EN 292-2

Product Description: **AIR TOOL**

Model Number: **CAT48**

Serial (Batch) No: _____

Signed

A handwritten signature in black ink, written over a horizontal line.

Clarke INTERNATIONAL
Epping, Essex, CM16 4LG, England

A SELECTION FROM THE VAST RANGE OF

Clarke®

QUALITY PRODUCTS

AIR COMPRESSORS

From DIY to industrial, Plus air tools, spray guns and accessories.

GENERATORS

Prime duty or emergency standby for business, home and leisure.

POWER WASHERS

Hot and cold, electric and engine driven - we have what you need

WELDERS

Mig, Arc, Tig and Spot. From DIY to auto/industrial.

METALWORKING

Drills, grinders and saws for DIY and professional use.

WOODWORKING

Saws, sanders, lathes, mortisers and dust extraction.

HYDRAULICS

Cranes, body repair kits, transmission jacks for all types of workshop use.

WATER PUMPS

Submersible, electric and engine driven for DIY, agriculture and industry.

POWER TOOLS

Angle grinders, cordless drill sets, saws and sanders.

STARTERS/CHARGERS

All sizes for car and commercial use.



PARTS & SERVICE: 020 8988 7400

E-mail: Parts@clarkeinternational.com or Service@clarkeinternational.com

SALES: UK 01992 565333 or Export 00 44 (0)1992 565335

Clarke® INTERNATIONAL Hernnall Street, Epping, Essex CM16 4LG
www.clarkeinternational.com