

A Jet self priming pump connected to a 24l tank

The booster sets are made up of a stainless steel pump, connected to a 24 litre tank with a 1" diameter flexible pipe with 90° elbow bend. The pumps start/stop operation is regulated by a Smart 10 electronic pressure switch.

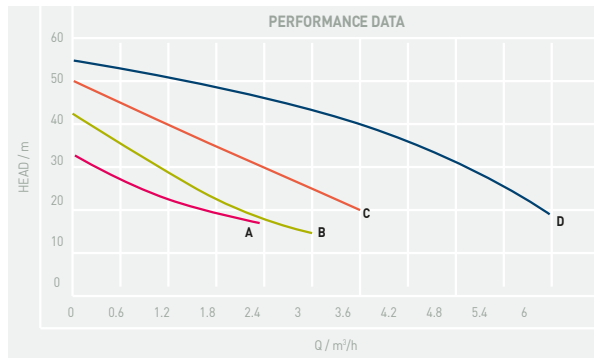

FEATURES

- Automatic start/stop
- Dry run protection
- Adjustable pressure setting
- Pump constructed in stainless steel
- Tank holds 24 litres with EDPM membrane
- Non-return valve on discharge.

TECHNICAL SPECIFICATION

PUMP TYPE	PRODUCT CODE	CURVE	INLET x OUTLET "/mm	kW	WEIGHT kg
BOOSTER SET - TT JET 35 AUTO with painted steel tank 230V/1Ph	PN/AUTOSMART35/1	/A	1 x 1 / 25 x 25	0.55	13
BOOSTER SET - TT JET 45 AUTO with painted steel tank 230V/1Ph	PN/AUTOSMART45/1	/B	1 x 1 / 25 x 25	0.55	13
BOOSTER SET - TT JET X M99 with painted steel tank 230V/1Ph	PN/AUTOSMART-J/1	/C	1 x 1 / 25 x 25	0.9	13
BOOSTER SET - TT CHLF4-60 with painted steel tank 230V/1Ph	PN/AUTOSMART46/1	/D	1 x 1 / 25 x 25	1.1	20

DIMENSIONAL DRAWING

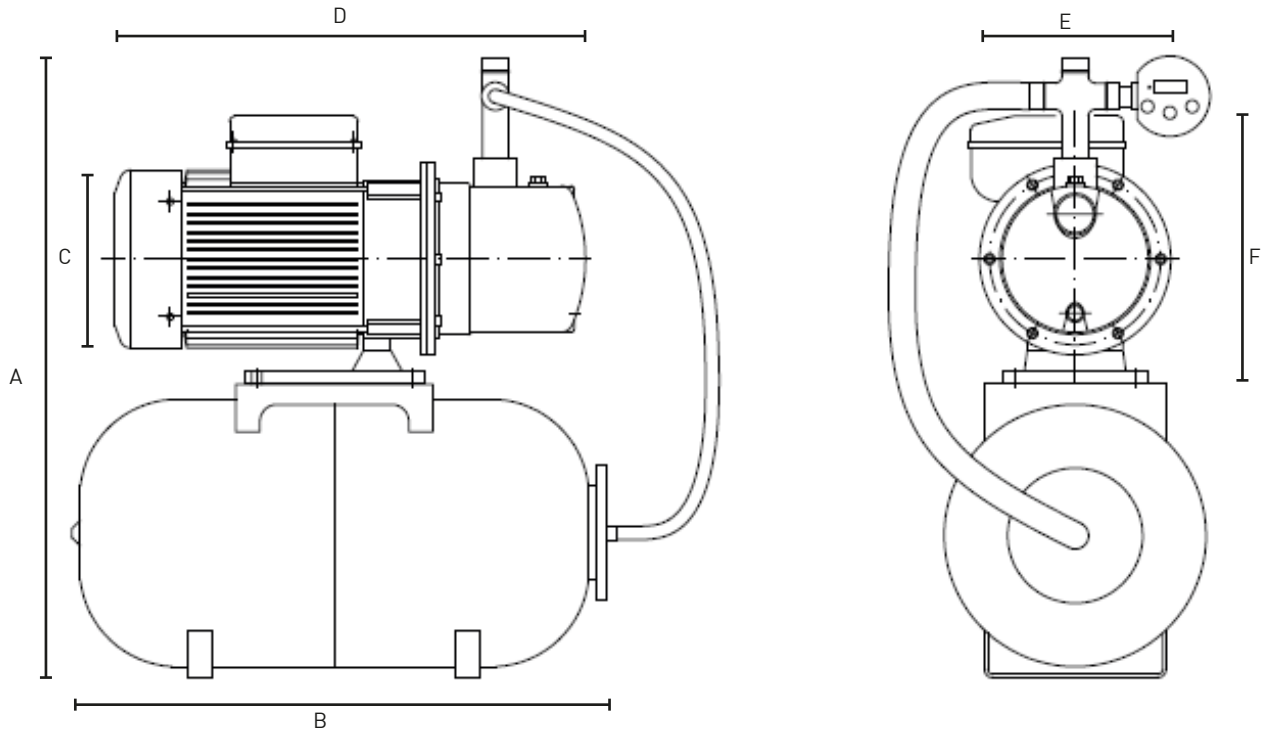

PUMP TYPE	A	B	C	D	E	F	G
BOOSTER SET - TT JET 35 AUTO with painted steel tank 230V/1Ph	640	560	160	432	170	238	300
BOOSTER SET - TT JET 45 AUTO with painted steel tank 230V/1Ph	640	560	160	432	170	226	300
BOOSTER SET - TT JET X M99 with painted steel tank 230V/1Ph	660	560					300
BOOSTER SET - TT CHLF4-60 with painted steel tank 230V/1Ph	660	560	170	482	130	225/245	300