

For all cars
**Cooling System Vacuum
Purge and Refill Kit**

LASER[®]

Instruction

4287



Distributed by The Tool Connection Ltd
Kineton Road, Southam, Warwickshire CV47 0DR
T +44 (0) 1926 815000 F +44 (0) 1926 815888
info@toolconnection.co.uk www.toolconnection.co.uk

Guarantee

If this product fails through faulty materials or workmanship, contact our service department direct on: +44 (0) 1926 818186. Normal wear & tear are excluded as are consumable items & abuse.



Cooling System Vacuum Purge and Refill Kit

Instructions

To purge the system

1. Drain water from cooling system.
2. Select suitable rubber bush to connect cooling system adapter to radiator or expansion tank neck.
3. Connect vacuum pump to cooling system adapter.
4. Connect to air compressor.
5. Switch on (Fig 2).
6. Allow air pressure to reach a vacuum level of approximately 20-25 in/HG (50-60cmHG) of mercury.
7. Turn off the switch and remove vacuum pump (Fig 3).

To refill the system

1. Connect coolant hose to cooling system adapter.
2. Put the other end in the reservoir of new or saved coolant.
3. Turn ON.
4. The coolant will flow into the radiator until the needle points to zero (Fig 4).
5. Check to see if the radiator is full of coolant.
6. Top up as necessary.

Cooling System Adapter

Vacuum Pump Adapter

Coolant Hose

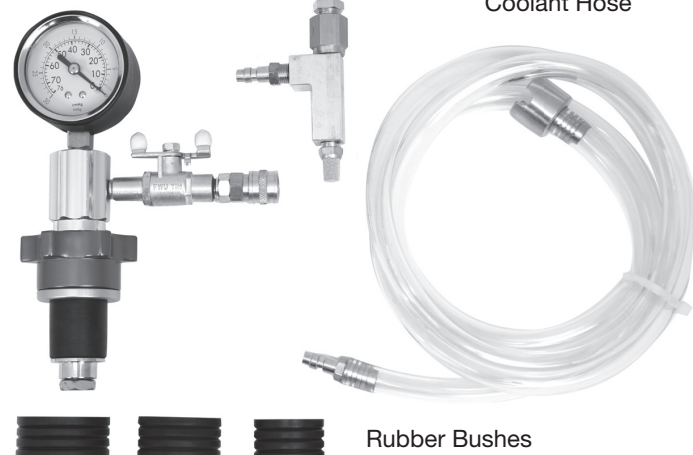

Rubber Bushes

Fig. 1

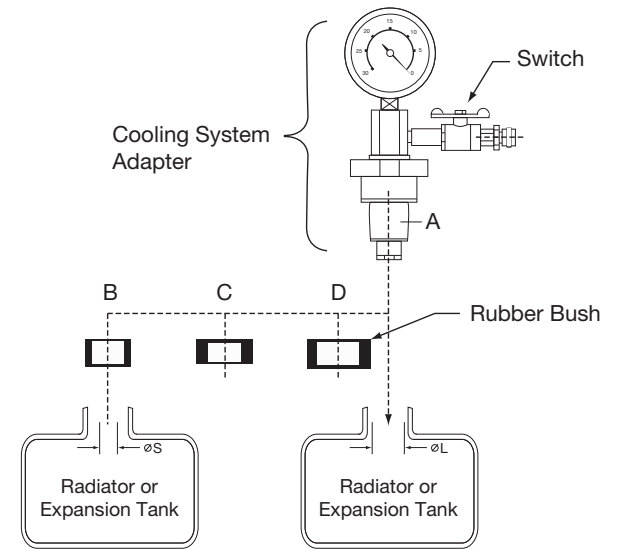

Fig. 2

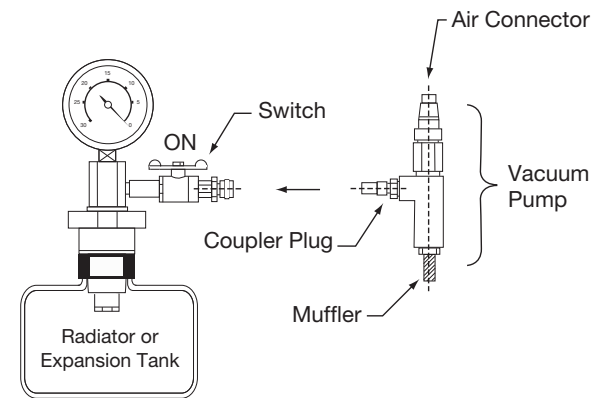

Fig. 3

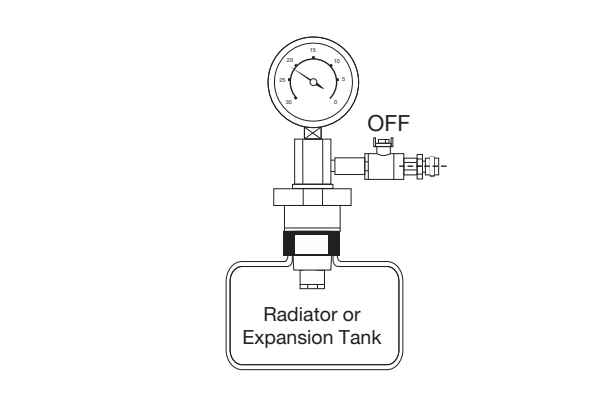

Fig. 4

